



M. B. Control & Systems Pvt. Ltd.

CIN: U67120WB1980PTC033012 | PAN: AABCM7980K | GST NO: 19AABCM7980K1ZU

Registered & Corporate Office

Srijan Industrial Logistic Park, Part A, Block B, 3rd Floor, NH 06, Howrah 711302

+91 9831330473, 9831206454 | +91 33 22870455 | enquiry@mbcontrol.com | www.mbcontrol.com



ISO 9001: 2015
IND/QMS/NAB-C1978/2658

Innovative Electronics For You

Ambient Pressure Sensor Operation Manual (RS-485)

MB MET 903



Document Number: M4 045 010 010 01 (R5)
(Applicable for HW Version- 200)

For service support call us on +91 8981051011 or mail us in service@mbcontrol.com



Table of Contents

| | |
|---|---|
| Table of Contents | 1 |
| 1. Overview..... | 2 |
| 2. Connection Diagram..... | 2 |
| 3. Technical Specification | 3 |
| 4. Modbus Register Addresses | 3 |
| 5. Re-setting Default Communication Parameter | 4 |
| 6. Revision History | 4 |

1. Overview

The MBMet-903 Series Pressure Sensor is designed for accurate and reliable pressure monitoring in demanding environmental and industrial applications. It delivers highly precise, fully calibrated measurements with excellent stability across a wide operating range.

Engineered with advanced pressure-sensing technology, the MBMet-903 offers low power consumption, fast response time, and long-term measurement consistency. Its robust design supports fixed installations and is optimized for integration into control systems using a DIN rail mounting system inside cabinets, ensuring secure installation, organized wiring, and ease of maintenance in industrial environments. The sensor maintains reliable performance even under harsh environmental conditions, including exposure to temperature variations and electromagnetic interference.

With its durable construction and high measurement accuracy, the MBMet-903 is ideal for enclosed monitoring system, where precise and stable pressure data is essential for performance analysis and operational reliability.

2. Connection Diagram

MBMet- 903 connections are shown in fig- 2.

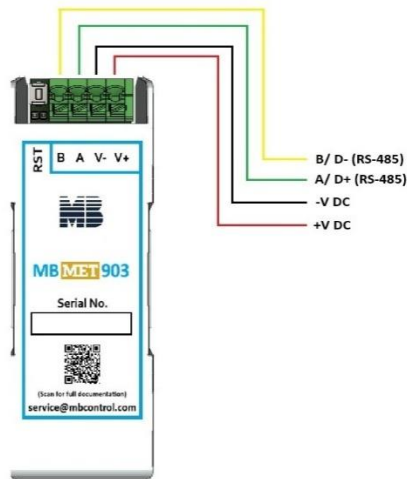

Fig- 2: Connection Diagram of Ambient Parameter Sensor

3. Technical Specification

| Features | Specification |
|-----------------------------|-----------------------|
| Measuring Range | 300 to 1250 hPa |
| Operating Temperature range | -40°C to +85°C |
| Operating Humidity range | 5% to 85% |
| Resolution | 0.01hPa |
| Absolute Pressure Accuracy | ±0.2 hPa |
| Response Time | 0.1s |
| Short term drift | ±0.01 hPa |
| Operating voltage | 9 to 32 VDC |
| Power consumption | 13 mA @ 12VDC |
| Weight | Approx. 40 gm |
| Dimension | 50 mm X 23 mm X 75 mm |
| Mounting Type | DIN rail Mounting |
| Sensor housing | ABS Enclosure |
| IP rating | IP20 |

Table- 3: Technical Specifications

4. Modbus Register Addresses

Measured parameters can be read as per model number only. Parameters not available will be read as '0' value.

| Registers Details | Register Addresses | Length | Parameters | Resolution | Register Type | Parameter Type |
|--------------------------|--------------------|---------|--|------------|---------------|------------------|
| Int Value | 1 | 16 Bits | Ambient Pressure | 0.01 | Read only | Signed 16 Bits |
| Float Value | 22, 23 | 32 Bits | Ambient Pressure | 0.01 | Read only | Float 32 Bits |
| Communication Parameters | 100 | 16 Bits | MODBUS ID (Default: 1) 1<ID<247 | - | Read/Write | Unsigned 16 Bits |
| | 101 | 16 Bits | Baud rate (Default: 1) 0=4800; 1=9600; 2=19200 | - | Read/Write | Unsigned 16 Bits |
| | 102 | 16 Bits | Parity (Default: 0) 0=None; 1=Odd; 2=Even | - | Read/Write | Unsigned 16 Bits |
| | 103 | 16 Bits | Stop bits (Default: 1) 1; 2 | - | Read/Write | Unsigned 16 Bits |
| | 105 | 16 Bits | Save configured parameter (Write 1 for save) | - | Write only | Unsigned 16 Bits |
| Device Information | 110 | 16 Bits | Device Model No: 9031 = MBMet-903 AB | - | Read only | Unsigned 16 Bits |
| | 111 | 16 Bits | Hardware Version | - | Read only | Unsigned 16 Bits |
| | 112 | 16 Bits | Software Version | - | Read only | Unsigned 16 Bits |
| | 113 | 16 Bits | Manufacture Year | - | Read only | Unsigned 16 Bits |
| | 114 | 32 Bits | Device Serial Number | - | Read only | Unsigned 32 Bits |

Table- 4: Modbus register addresses

5. Re-setting Default Communication Parameter

Step-1 Locate the Reset Button on the sensor, as shown in Fig- 7.



Fig- 7: Position of Reset Button

- Step-2 Verify that the device's power status is ON.
- Step-3 Press and hold the Reset Button for more than three seconds, and then release it.
- Step-4 Wait for 15 seconds.
- Step-5 Communicate with the device using the default communication parameters.

**** (to be done by experienced MBCS engineers only)**

6. Revision History

| Revision Ver. | Date | Revision Details |
|---------------|----------|---|
| R0 | 05/01/25 | Manual Created. |
| R1 | 08/01/25 | Overview portion added. Model Numbers are added. |
| R2 | 27/03/26 | Temperature, Humidity and Dew point, these three parameters are removed. Changed information as per parameters. |
| R3 | 28/03/26 | Accuracy value changed, more specifications are added. |
| R4 | 23/04/26 | Modified Technical specification table. |
| R5 | 23/04/26 | Modified overview. |