



# MB **LOGGER** 1000 Pro

Industrial Grade Dataloggers specially Tailored for Meteorological Applications



Document ID: M4 041 010 020 01

Version: R16  
2026/05/22



# M. B. Control & Systems Pvt. Ltd.

CIN: U67120WB1980PTC033012 | PAN: AABCM7980K | GST NO: 19AABCM7980K1ZU

Registered & Corporate Office

Srijan Industrial Logistic Park, Part A, Block B, 3rd Floor, NH 06, Howrah 711302

+91 9831330473, 9831206454 | +91 33 22870455 | enquiry@mbcontrol.com | www.mbcontrol.com



Innovative Electronics For You

## Table of Contents

1. Warnings.....	8
2. MLogger Series.....	9
2.1 MLogger Applications.....	10
2.2 MLogger Model Details .....	10
2.3 MLogger Special Functions.....	10
3. MLogger Connections.....	11
3.1 MLogger Ports and Terminals.....	11
3.2 MLogger Power Supply Connections.....	13
3.3 Serial Port -1 (RS485).....	13
3.4 Serial Port -2 (RS485 or RS232).....	14
3.5 Port ETH .....	15
3.6 SD Memory Card .....	16
3.7 Internal Modem.....	16
3.8 Digital Inputs.....	18
3.9 Measurement Voltage (0-10VDC) Input Terminals .....	19
3.10 Measurement mA (4-20mA) Input Terminals.....	19
3.11 Measurement Voltage (0-1VDC) Input Terminals .....	20
3.12 Battery Voltage Measurement Terminals .....	21
3.13 RTD Measurement Terminals.....	22
4. MLogger Display.....	23
4.1 Status LED Display.....	23
4.2 Datalogger Operation Keys.....	24
4.3 Datalogger OLED .....	25
4.4 OLED Power On.....	28
4.5 Datalogger Status Display.....	28
4.6 MyPage Parameters Display .....	28
4.7 MLogger Message Display.....	29
4.8 Analogue Input – mA Value Display.....	30
4.9 Analogue Input – Voltage Value Display .....	30
4.10 Analogue Input – Milli Voltage Value Display .....	31
4.11 Analogue Input – Battery Voltage Display .....	32
4.12 Analogue Input – RTD Input Display .....	32

4.13	Digital Inputs Status .....	33
4.14	Sensors and IED Parameters Display .....	34
4.15	Plant Parameter Display .....	35
4.16	Albedo Parameter Display .....	35
4.17	Today Solar Energy Display .....	35
5.	Setting Default IP Address .....	36
6.	Embedded Webserver .....	37
6.1	User Login.....	38
6.2	Welcome Page.....	39
6.3	Datalogger Configuration Files.....	40
6.4	Configure – Power Save.....	41
6.5	Configure – Datalog Files .....	44
6.5.1	Log File Configuration: .....	45
6.5.2	Remote File Transfer Configuration:.....	46
6.6	Configure – Cellular Modem .....	49
6.7	Configure – GPS .....	50
6.8	Configure – Device Location .....	51
6.9	Configure – Serial Port-1 (RS485).....	51
6.10	Configure – Serial Port-2 .....	52
6.10.1	Configure – Serial Port-2 (RS485).....	53
6.10.2	Configure – Serial Port-2 (RS232).....	53
6.10.3	Configure – Serial Port-2 (RS232) – MODBUS RTU Master.....	54
6.10.4	Configure – Serial Port-2 (RS232) – MODBUS RTU Slave .....	55
6.10.5	Configure – Serial Port-2 (RS232) – ASCII Master/ Slave .....	55
6.11	Configure – ETH Network.....	55
6.12	Configure – Sensors and IED on MODBUS Master Ports.....	56
6.12.1	IED Communication .....	57
6.12.2	IED MODBUS Parameters .....	58
6.12.3	IED Parameter Configuration .....	59
6.13	Configure – Sensors and ASCII IED on Serial RS232 Port.....	61
6.13.1	IED Communication .....	61
6.13.2	IED ASCII Parameters .....	62
6.13.3	ASCII IED Parameter Configuration.....	63
6.14	Configure – SNTP Client .....	65
6.15	Configure – IOT (MQTT).....	66
6.16	Configure – Analog Input Channels.....	67
6.16.1	Configure – Analog Input mA.....	68
6.16.2	Configure – Analog Input mV .....	69
6.16.3	Configure – Analog Input V .....	71

6.16.4	Configure – Analog Input Battery Voltage .....	73
6.16.5	Configure – RTD Sensor Input .....	74
6.17	Configure – Digital Inputs .....	75
6.18	MyPage Parameters.....	77
6.18.1	My Page – Parameter Configuration.....	77
6.19	User Configuration.....	79
6.20	Commit Configuration .....	80
6.21	Plant Parameters – Special Function.....	80
6.21.1	Sun Rise and Set Time.....	81
6.21.2	Solar Plant Parameters.....	82
6.21.3	Albedo Meter .....	84
6.21.4	Today Solar Energy.....	85
7.	Embedded Webserver– Diagnostics.....	86
7.1	MLogger Status .....	87
7.1.1	MLogger Status .....	87
7.1.2	MLogger Modem Status .....	88
7.1.3	MLogger GPS Status.....	89
7.2	MyPage Parameters.....	90
7.3	Plant Parameter Values – Special Functions .....	90
7.3.1	Plant Parameters.....	90
7.3.2	Albedometer Values.....	91
7.3.3	Today Solar Energy Values.....	91
7.4	Data Log Files .....	92
7.4.1	Data Log Files .....	92
7.4.2	DataLog Files RFT-1 and RFT-2 .....	93
7.4.3	Delete All Data Log Files.....	94
7.4.4	Format Media.....	94
7.5	Sensor / IED Parameters .....	95
7.5.1	Sensor/ IED Communication Status .....	95
7.5.2	Sensor/ IED Parameter Values .....	96
7.6	Analog Input Channels.....	97
7.6.1	Measured –Input mA Value .....	97
7.6.2	Measured –Input mV Value .....	98
7.6.3	Measured –Input Voltage Value .....	98
7.6.4	Measured –Battery Voltage.....	99
7.6.5	Measured –RTD Temperature Values.....	99
7.7	Digital Inputs.....	100
7.8	MLogger Operation Messages.....	101
7.9	Datalogger Diagnostics Configuration.....	101

7.10	Datalogger Diagnostic Logs.....	103
7.10.1	Download MBLogger Status Report.....	104
7.10.2	Download MBLogger Value Report.....	104
7.10.3	Delete MBLogger Messages.....	105
7.10.4	Download Modem Comm Log .....	105
7.10.5	Download ADC1 or ADC2 Logs .....	105
7.10.6	Download MODBUS Comm log.....	105
7.10.7	Download Restart MB Log .....	105
7.10.8	Download DataLogSts .....	105
7.10.9	Download MQTT Log.....	105
7.10.10	Delete MQTT Save Msg File .....	105
7.11	Datalogger Remote Diagnostics.....	106
8.	MBLogger Messages.....	107
8.1	MBLogger Information Messages .....	107
8.2	MBLogger Fault Messages .....	114
9.	Technical Specifications.....	116
9.1	General Specifications: .....	116
9.2	Analog Inputs:.....	116
9.3	Digital Inputs: .....	116
9.4	Status LED:.....	116
9.5	Colour OLED and Keypad:.....	117
9.6	Communication Serial Port-1 (RS485):.....	117
9.7	Communication Serial Port-2 (RS232 or RS485):.....	117
9.7.1	Communication Serial Port-2 (RS485):.....	117
9.7.2	Communication Serial Port-2 (RS232):.....	117
9.8	Communication Port ETH.....	118
9.9	Internal Modem.....	118
9.10	Datalogging.....	118
9.11	Electrical .....	118
9.12	Environmental .....	119
9.13	Physical .....	119
9.14	Add ON- Module (High Speed Digital Inputs).....	119
10.	MBLogger MODBUS Slave Registers.....	120
10.1	Data Logger Time .....	120
10.2	My Page Parameters.....	120
10.3	Analog Inputs (mA) .....	121
10.4	Analog Inputs (mV) .....	121
10.5	Analog Inputs (V) .....	122
10.6	Battery Voltage Input.....	122

10.7	Digital Inputs.....	123
10.7.1	Digital Input – Status.....	123
10.7.2	Digital Input- Rain Gauge .....	123
10.7.3	Digital Input – Wind speed.....	123
10.8	Sensors and IED Connected to Serial and ETH Ports.....	124
10.8.1	Serial Port RS485-1.....	124
10.8.2	Serial Port RS485-2.....	125
10.8.3	Serial Port RS-232-2 – ASCII IED .....	126
10.8.4	Serial Port RS-232-2 – MODBUS RTU IED.....	127
10.8.5	ETH Port .....	128
10.9	Measured Parameters and IED Communication Status.....	130
10.10	Solar Parameters.....	130
10.11	Albedo Parameters .....	131
10.12	Today Solar Energy Parameters .....	131
10.13	Datalogger Status Parameters.....	133
11.	MLogger Error Diagnostics .....	134
11.1	Download Datalogger Status and Values Report:.....	134
11.2	Embedded Web server .....	134
11.3	ETH Network.....	134
11.4	Datalogger Modem.....	135
11.5	Data logger GPS.....	135
11.6	Analog Input Channels.....	135
11.7	Digital Input Channels .....	136
11.8	Sensor and IED Interfaced to Serial Ports (RS485 and RS232).....	136
11.9	Sensor and IED Interfaced to ETH Port.....	137
11.10	File Transfer Operation.....	137
11.11	Datalogging Operation .....	137
11.12	IOT Data Transfer Operation .....	138
12.	MLogger Library .....	138
12.1.	Library for Digital Input Channels.....	138
12.2	Library for Analog mA Input Channels .....	139
12.3	Library for Analog mV Input Channels .....	140
12.4	Library for Analog Voltage Input Channels.....	140
12.5	Library for Sensors/ IED for RS485 Ports MODBUS – RTU Protocol.....	141
12.5.1	Ambient Parameter Sensors .....	141
12.5.2	PV Module Sensors .....	141
12.5.3	Wind Speed and Direction Sensors.....	142
12.5.4	Pyranometers .....	142
12.5.5	Inverters.....	143

12.5.6	MFM	143
12.5.7	Rain Gauge	143
12.5.8	Smart Box	143
12.5.9	Soil Sensors	143
12.5.10	Solar Monitoring System	143
12.6	Library for Sensors/ IED for RS232 Port– ASCII Protocol	143
12.6.1	Wind Parameter Sensors	144
12.6.2	Cloud Cover Sensors	144
12.7	Library for Sensors/ IED for RS232 Port – MODBUS RTU Protocol	144
12.7.1	Visibility Distance Sensor	144
12.8	Library for Sensors/ IED for ETH Ports – MODBUS TCP Protocol	144
12.8.1	MFM	144
12.8.2	Inverters	144
12.8.3	Solar Monitoring System	145
12.9	Special Function – Sunrise and set time – States and Locations	145
13	Revision History	146

# 1. Warnings

---

- Installation at site should be done by skilled and qualified personal after taking required approvals.
- Use proper protection gear and tool while installing the device.
- Be aware of your surroundings while doing the installation work.
- Serious injury can occur if proper safety norms are not followed.
- Compliance with all utility and electrical safety codes regulations are mandatory.
- Read the manual and get acquainted with the datalogger connections and terminals before commencing installation activity.
- Before connecting the datalogger, read its label to confirm power supply requirements.
- All connections should be done only when power to datalogger is switched off.
- Improper installation and connections may damage the device and sensor connected to the same.
- Protect from overvoltage, **surges** of all kinds and static electricity.
- To prevent potential fire or shock hazard, do not expose the datalogger to rain or moisture.
- Physically damaged datalogger should not be used or connected to main power.
- Use proper earth connection.

## 2. MBLLogger Series

---

MBLogger series is advanced range of datalogger designed for many applications. The data logger series provides following advanced functions:

- Uses latest ARM 32 bits processor.
- Acquire reliable measurement data from multiple industrial devices e.g. PLC, weather sensors, inverters, energy meters.
- Provides multiple measurement inputs for analogue and digital measurements.
- High precision measurements – 24 bits for analogue inputs.
- Provides various communication ports RS485 (isolated), RS232 and ETH.
- Modem 4G for communication.
- Multiple communication protocols – MODBUS RTU (master and slave), MODBUS TCP (master and slave), MQTT, SNTTP, FTP and DNS.
- IOT communication
- Daylight saving time configuration.
- All measured and read parameters are available as MODBUS (RTU or TCP) slave parameters.
- External SD memory card (16GB) for data logging. Some devices have internal 4GB SD memory.
- Programmable data logging interval.
- LED display for status and device health.
- Keyboard for OLED operation.
- OLED display (based on model selected) for display of measured parameters and device diagnostics.
- Internal device library (for sensors, inverters and MFM) for easy and simple interface of the same.
- Embedded webserver for configuration of datalogger functions and diagnostics (real time view of measured parameters). No programming is required.
- MyPage – to display user selected parameters in one OLED and webserver page.
- Internal battery backed up real time clock (RTC).
- Data file transfer to two file servers.
- Statistical functions – average, minimum, maximum, and standard deviation.
- memory of 32MB and expandable SD card memory up-to 16GB, MBLLogger series are ideal for datalogging.
- Log for user activity (login and logout) and device messages/ faults.
- Power saving operation mode.
- Saving of integrated values.
- Option provided for calculation of following plant parameters-
  - a. Sunshine duration
  - b. Day solar energy
  - c. Day Rain (mm)
  - d. Sunrise and set time with day sunshine duration.
  - e. Solar Energy generated (WH).
  - f. Today solar energy
  - g. Sun presence
  - h. Albedometer calculations
- Add-on expansion modules available for special operations.
- **Excellent on-site and remote diagnostic support with datalogger status and value reports.**

## 2.1 MBLLogger Applications

MBLogger can be used in various applications:

- Solar plant monitoring
- Energy monitoring
- Water resources monitoring
- Metrology parameters collection and transmission
- Agricultural and agricultural research.
- Remote asset monitoring and control.
- Manufacturing measurements

## 2.2 MBLLogger Model Details

Various features available in MBLLogger series are shown in table 2.1 below:

Sl. No.	Features	1000 Lite	1000 Pro
1	<b>Port Serial Port -1</b> RS-485 (MODBUS RTU Master, MODBUS RTU Slave)	15	15
2	<b>Port Serial Port-2</b> RS-485 (MODBUS RTU Master, MODBUS RTU Slave) Or RS232 (ASCII Master or ASCII Slave)	-	15 Or 2
3	<b>Port ETH</b> (MODBUS TCP Master) (MODBUS TCP Slave, Web Server)	✓	15
4	<b>Cellular Modem</b>	-	✓
5	<b>OLED Display</b>	-	✓
6	<b>EMMC (16GB)</b>	✓	✓
7	<b>Maximum number of MODBUS TCP Slave clients</b>	2	4
8	<b>SNTP Client</b>	1	1
9	<b>File Transfer Clients</b>	2	2
10	<b>RTC (battery backed up)</b>	✓	✓
11	<b>Digital Inputs (optically isolated)</b>	4	4
12	<b>Current inputs: mA inputs- (4-20mA) (24 bits)</b>	4	4
13	<b>Voltage inputs: mV inputs (0-1,000mV) (24 bits)</b>	4	4
14	<b>Voltage inputs: mV inputs (0-10,000mV) (24 bits)</b>	-	4
15	<b>RTD Input (PT100/ PT1000)</b>	-	1
16	<b>Add on Expansion Modules</b>	-	✓
17	<b>Special Functions (see section 2.3)</b>	-	✓

Table-2.2: MBLLogger variants

Notes:

- For port RS232 (ASCII or MODBUS protocols), only one IED can be interfaced.

## 2.3 MBLLogger Special Functions

Following special functions are available. These special functions require additional licenses to be added to the datalogger.

These special functions can also be installed at site based on firmware version of the datalogger.

Sl. No.	Special Function	Features	License Code
1	Plant Parameters	Sunshine duration (requires installation of at least one pyranometer). Sunrise and set time (require access to internet via modem or ETH port). Day Duration Day Solar Energy Calculation (requires installation of at least one pyranometer). Day Rain measurement (requires installation of at least one rain gauge). Set Solar noon time (not required if GPS or Sntp is enabled). Today Solar Energy (WH) Sun presence Albedometer calculations	MBLog_SplFnc_001

Table-2.3: MBLogger special functions

Features available in your MBLogger will depend on the model selected and special function licenses installed.

### 3. MBLogger Connections

MBLogger connections are described in this section. All connections described here may not be available in your datalogger. Features and connections available will depend on the MBLogger model selected.

#### 3.1 MBLogger Ports and Terminals

Ports and input terminals of MBLogger are shown below.

Configuration details for each of these are provided in chapter for embedded webserver.

Plug-in terminals are provided for most of the connection for easy installation and maintenance at site.

Communication ports connectors and terminal details are provided in figures below.



Figure-3.1.1: MBLogger communication ports and terminals (For Hardware version 2.11)



Figure-3.1.2: MBLLogger Signal input terminals (For Hardware version 2.11 and 3.11)

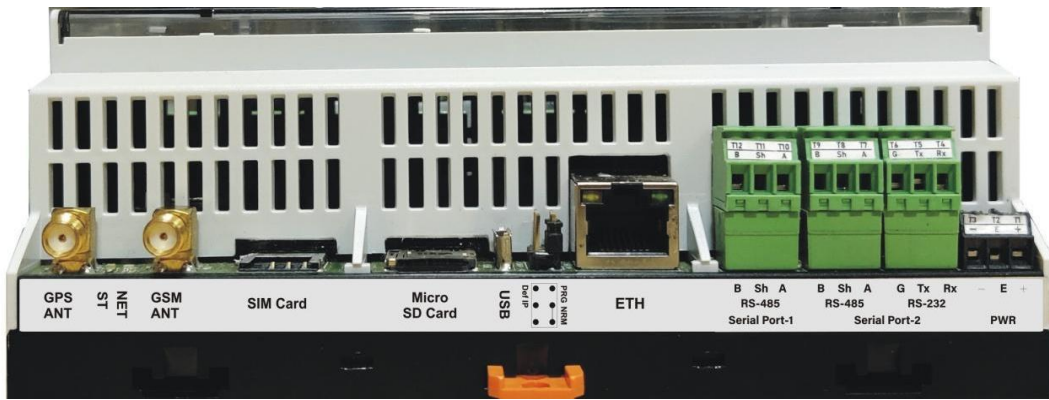

Figure-3.1.3: MBLLogger communication port and terminals (For Hardware version 3.11)



Figure-3.1.4: MBLLogger communication port and terminals (For Hardware version 5.11)

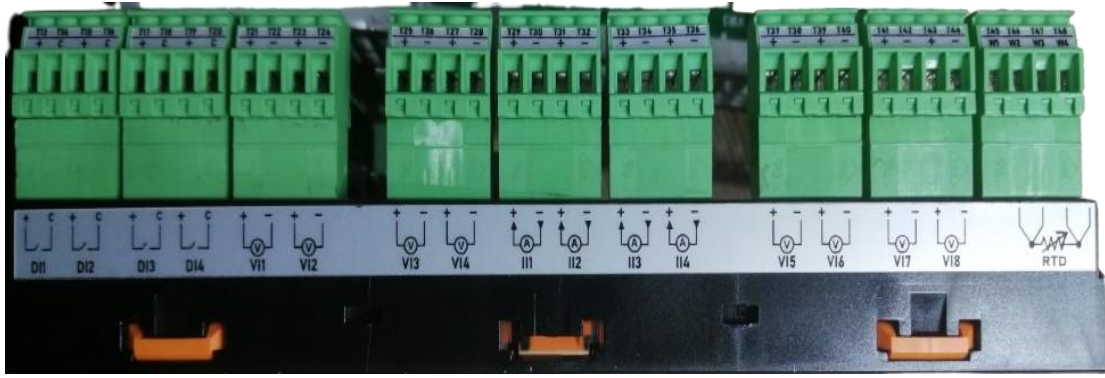

Figure-3.1.5: MBLLogger signal input terminals (For Hardware version 5.11)

Each of these connections are explained in sections below.

### 3.2 MBLLogger Power Supply Connections

MBLogger power supply connections are shown in figure 3.2 below. **These terminals are not plugin type.**

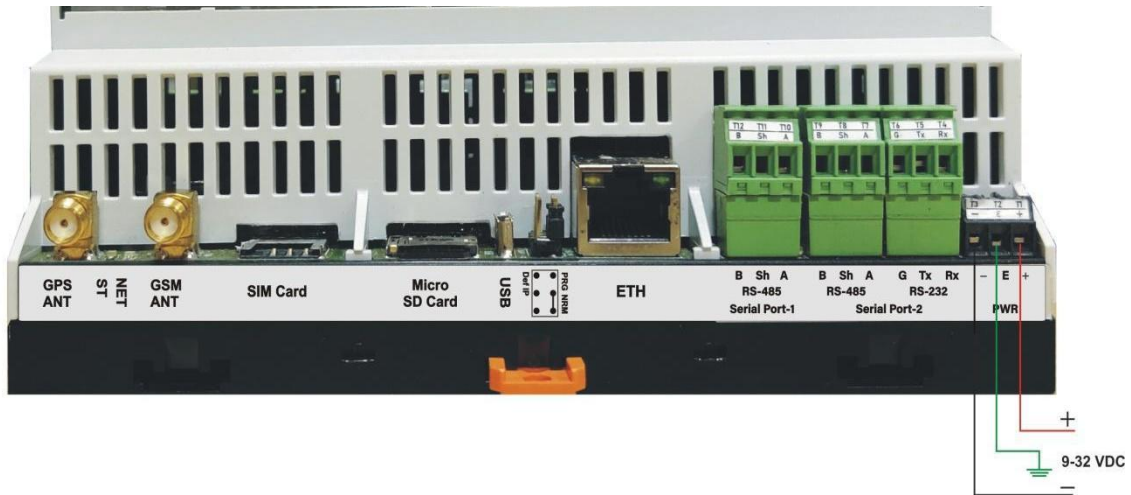

Figure-3.2: MBLLogger power supply connections.

Power supply connections details are listed in table-3.2 below.

Terminal	Function	Remarks
T1	V+	Voltage Range: DC 9 to 32VDC
T2	Earth	Power Consumption (Without modem) – 4W
T3	V-	Power Consumption (With modem)- 10W

Table-3.2: MBLLogger power supply connections

Use proper surge protection and MCB for power connections. Earth connection should be connected to proper earth.

### 3.3 Serial Port -1 (RS485)

MBLogger serial port-1 (RS485) are shown in figure 3.3 below.

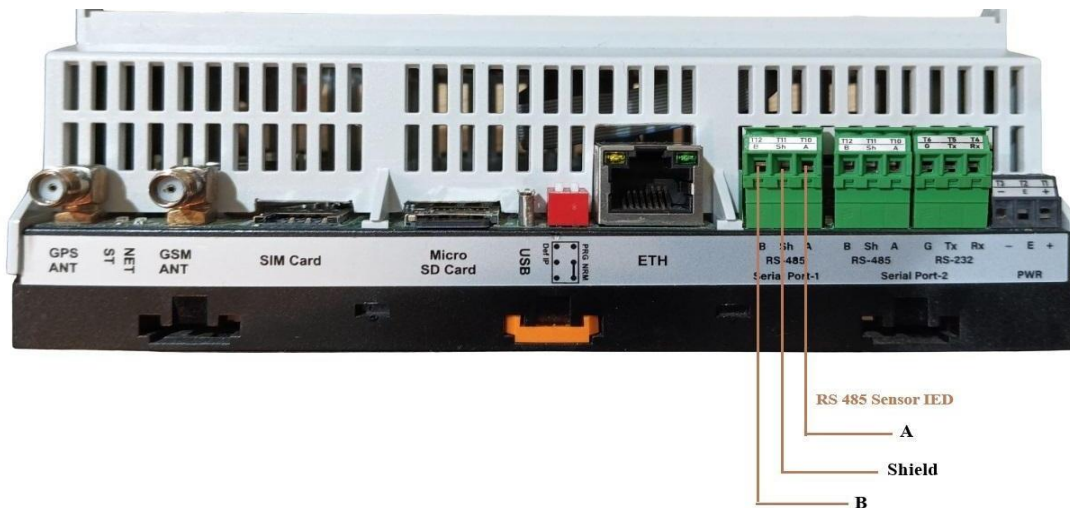

Figure-3.3: MBLLogger serial port-1 (RS485) connections.

Connection details for the serial port are listed in table-3.3 below.

Terminal	Function	Remarks
T10	A	Isolated RS485 port.
T11	Shield	LED Rx and Tx provide for indication. Can operate as MODBUS RTU master or MODBUS RTU Slave.
T12	B	In MODBUS RTU Master mode, up to five external devices (sensors or other devices) can be interfaced to the port. Configuration details for the port are provided <a href="#">here</a> . Use low capacitance, twisted pair and shielded cable for connecting devices to the port.

Table-3.3: MBLLogger serial port-1 (RS485) connections

### 3.4 Serial Port -2 (RS485 or RS232)

MBLogger serial port-2 can be used as RS485 or RS232. Only one of the two ports can be used at any time. Connections for this port are shown in figure 3.4 below.

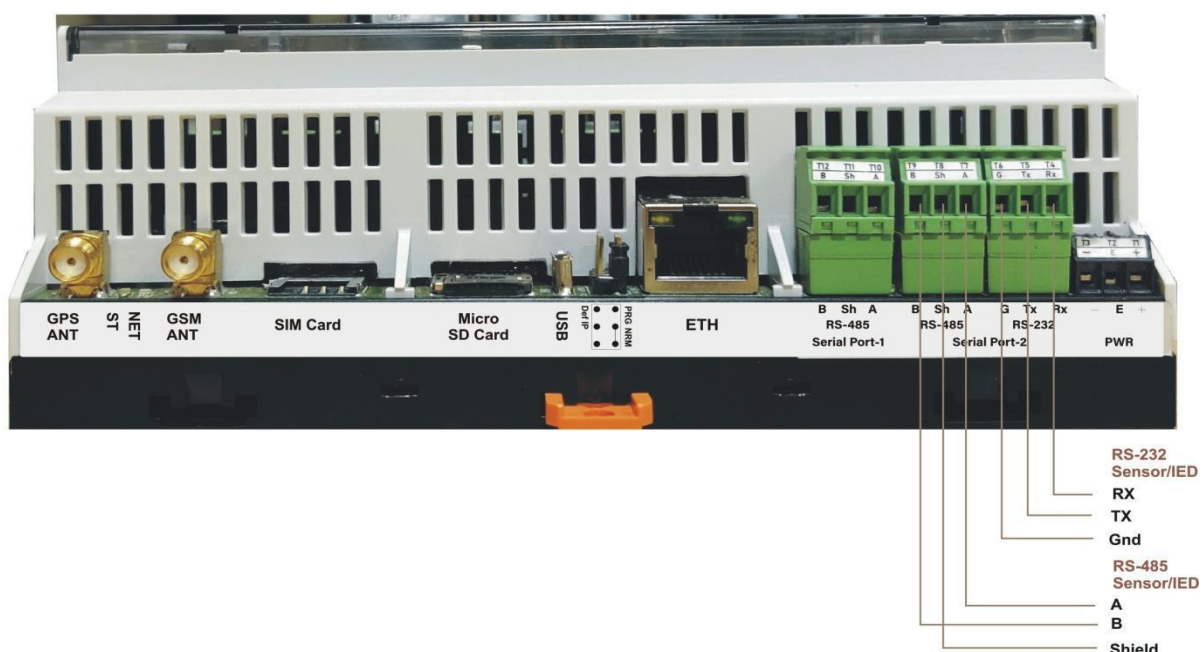

Figure-3.4: MBLLogger serial port-2 (RS485 or RS232) connections.

Connection details for the serial port are listed in table-3.4 below.

Terminal	Function	Remarks
T4	Rx	Non-isolated RS232 port.
T5	Tx	LED Rx and Tx provide indication for port activity.
T6	Gnd.	Can operate ASCII Master/ Slave or MODBUS RTU Master/ Slave. Configuration details for the port are provided <a href="#">here</a> . Use three core shielded cable for connecting one device to the port.
T7	A	Isolated RS485 port.
T8	Earth	LED Rx and Tx provide indication for port activity.
T9	B	Can operate as MODBUS RTU master, MODBUS RTU Slave or ASCII Master In MODBUS RTU Master mode, up to five external devices (sensors or other devices) can be interfaced to the port. Configuration details for the port are provided here. Use low capacitance, twisted pair and shielded cable for connecting devices to the port.

Table-3.4: MBLLogger serial port-2 (RS485 or RS232) connections

### 3.5 Port ETH

This ETH port (base 10MHz) is multi- function port.

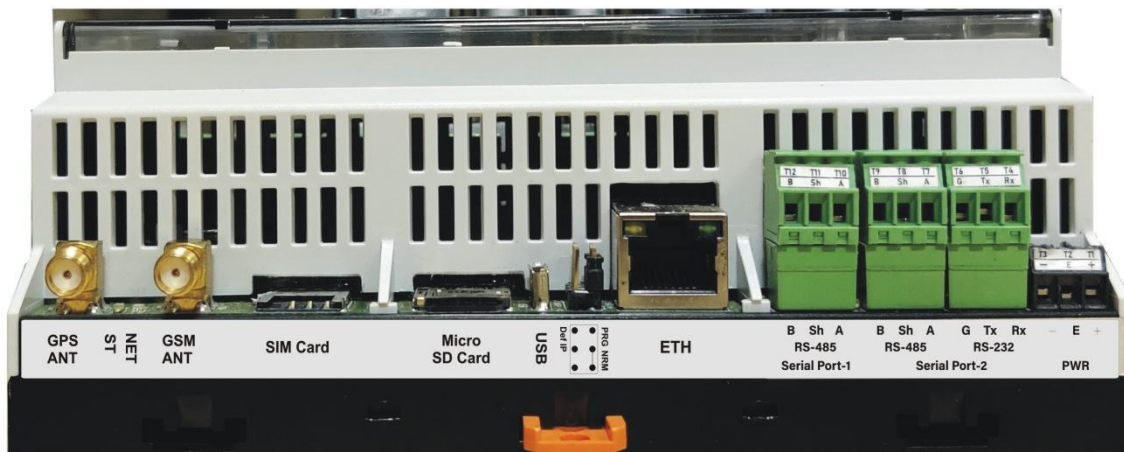

Figure-3.5.1: MBLLogger ETH Port.

Use standard LAN cable with RJ 45 connector for connecting to the port.  
Port activity LED are provided on the connector.

This port is used for following operations:

- i) Configuration of data logger via embedded web server.
- ii) Downloading logged file.
- iii) Interface to MODBUS TCP sensors and devices. Up-to five devices can be connected to the port.
- iv) MODBUS TCP slave (multiple masters) to provide measured and collected parameters to other devices and SCADA.
- v) SNTP Client for time synchronization.
- vi) File transfer client (ftp).
- vii) IOT communication.
- viii) Remote diagnostics.

Configuration details for ETH port are provided [here](#).

Internet connection should be provided to the datalogger for availing remote communications. Status and activity details of ETH port are also provided by embedded web server and front panel OLED.

Default network configuration for the datalogger is provided in table 3.5.2 below.

Sr No.	Description	Value
1	Device IP	192.168.100.226
2	Network Mask	255.255.255.0
3	Network Gateway IP	0.0.0.0
4	Primary DNP IP	8.8.8.8
5	Secondary DNS IP	8.8.4.4

Table-3.5.2: Default datalogger network configuration

### 3.6 SD Memory Card

MBLogger supports microSD memory card up-to 16GB. Some models have internal 4GB SD memory, these models will not have the SD card holder.



Figure-3.6: MBLogger SD card slot.

*Improper inserting of SD card may damage the holder and void the device warranty.*

SD memory is used for data logging and saving IOT messages.

Configuration of data logging operations are provided [here](#).

### 3.7 Internal Modem

Availability of internal modem is based on selected model.

High speed 4G modem (CAT-1) is provided.



Figure-3.7: MBLLogger internal modem.

Micro SIM slot is provided. Push the SIM inside to lock or un-lock the same.  
*Improper inserting of SIM may damage the holder and void the device warranty.*

Use the antenna provided along with the modem.  
 Contact our sales team if high gain antenna is required.

Modem configuration details are provided [here](#).  
 Install and use GSM antenna for GSM/ GNSS services. GSM can be used to location and time synchronization and device location detection. *GSM antenna should be exposed to open sky so that it can track required satellites.*

It will take about three to five minutes for GPS to track the satellites and synchronize.  
 GPS location and time service can be used even if SIM is not installed in the modem.

GPS configuration details are provided [here](#).  
 Details of modem status LED's are provided in table-3.7 below.

LED	Colour	Remarks
Modem Status	Green	Always OFF: Modem not ready. Always ON: Modem ready for operation.
Net Status	Blue	Always OFF: Power OFF. Always ON: Searching for network. ON 200mSec and OFF 200mSec: 4G registered. ON 800mSec and OFF 800mSec: 2G/ 3G registered.

Table-3.7: Modem status LED.

Modem status and activity details are also provided by embedded web server and front panel OLED.  
 The modem can be used for following operations:

- i) SNTP Client for time synchronization.
- ii) File transfer client (ftp).
- iii) IOT communication.
- iv) Remote diagnostics.

Configuration details for the modem are provided [here](#).

## 3.8 Digital Inputs

Up to four optically isolated and potential free digital inputs are provided.

Connections for digital input terminals for potential free contacts are provided in figure – 3.8.1 below.

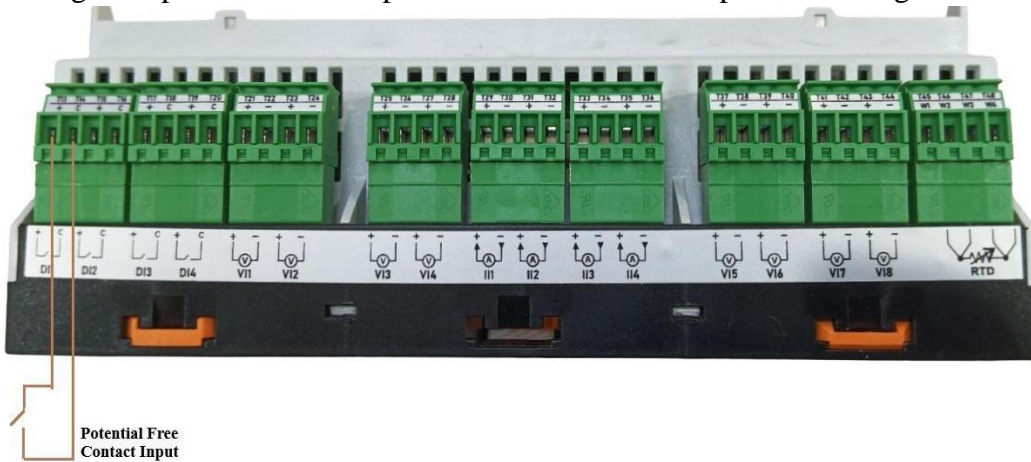

Figure-3.8.1: Digital input connections for potential free contacts.

Connections for digital input terminals for open collector transistor inputs are provided in figure – 3.8.2 below.



Figure-3.8.2: Digital input connections for open collector transistor inputs.

Connection details for digital inputs are listed in table-3.8 below.

Terminal	Function	Remarks
T13	DI1+	Optically Isolated and potential free digital inputs.
T14	DI1C	Can be used for following functions/ sensors:
T15	DI2+	Status monitoring
T16	DI2C	Pulse accumulation
T17	DI3+	Rain gauge
T18	DI3C	Wind speed
T19	DI4+	Etc.
T20	DI5C	Configuration details for digital inputs are provided <a href="#">here</a> .

Table-3.8: MBLogger digital input connections

### 3.9 Measurement Voltage (0-10VDC) Input Terminals

Up to four differential measurement voltage inputs (0-10VDC) are provided. Connections for these voltage input terminals are provided in figure – 3.9 below.

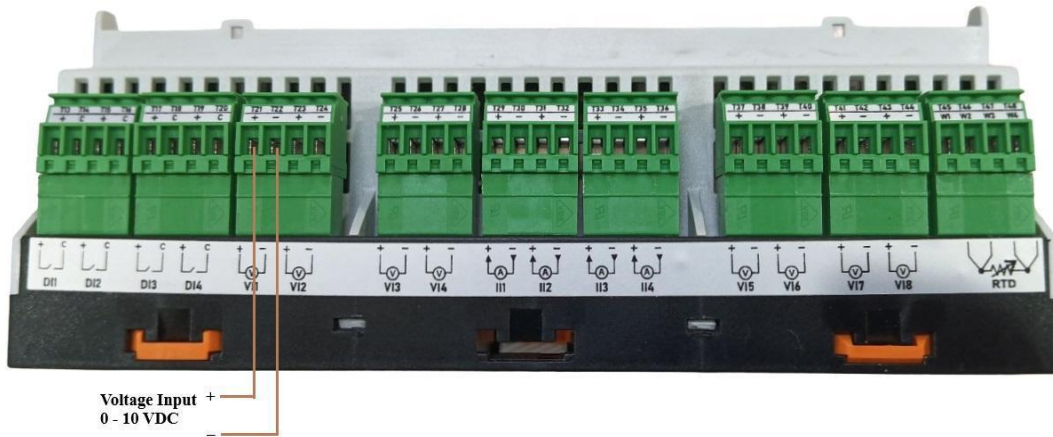

Figure-3.9: Measurement voltage (0-10VDC) input connections.

Connection details for voltage inputs are listed in table-3.9 below.

Terminal	Function	Remarks
T21	VI1+	Isolated measurement differential voltage inputs. ADC resolution – 24 bits
T22	VI1-	
T23	VI2+	Can be used for following functions/ sensors: Measure 0-10VDC differential signals.
T24	VI2-	
T25	VI3+	Pyranometers Solar irradiation transducers
T26	VI3-	
T27	VI4+	Wind speed Wind direction Others.
T28	VI4-	
		Configuration details for these voltage inputs are provided <a href="#">here</a> .

Table-3.9: MBLogger differential voltage (0-10VDC) input connections

### 3.10 Measurement mA (4-20mA) Input Terminals

Up to four measurement mA inputs (4-20mA) are provided.

Connections for these mA input terminals are provided in figure – 3.10 below.

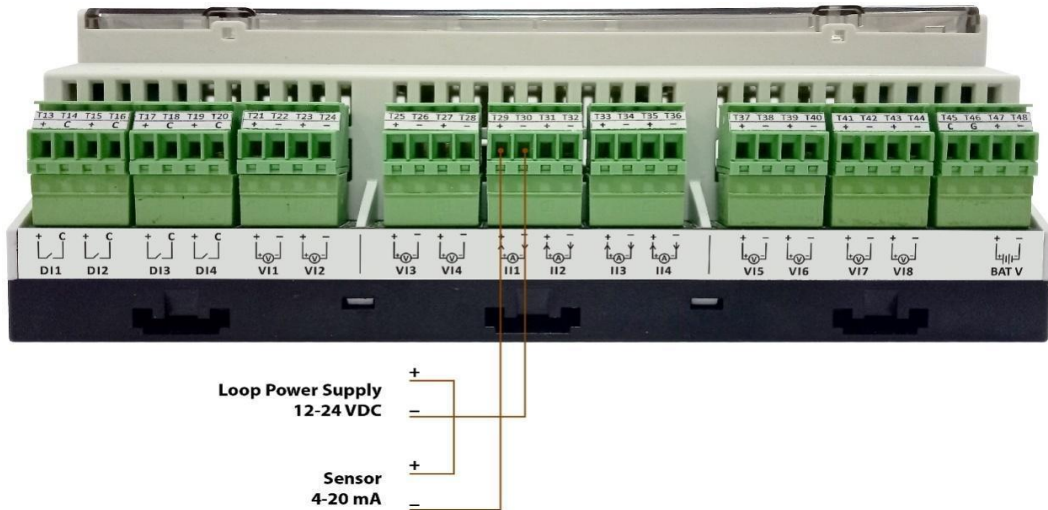

Figure-3.10: Measurement mA (4-20mA) input connections.

Connection details for mA inputs are listed in table-3.10 below.

Terminal	Function	Remarks
T29	II1+	Isolated measurement mA (4-20mA) inputs. ADC resolution – 24 bits with sensor break detection. Can be used for following functions/ sensors: Measure 4-20mA signals. Pyranometers Solar irradiation transducers Wind speed Wind direction PV Module temperature Ambient parameters Etc. Configuration details for these voltage inputs are provided <a href="#">here</a> .
T30	II1-	
T31	II2+	
T32	II2-	
T33	II3+	
T34	II3-	
T35	II4+	
T36	II5-	

Table-3.10: MBLogger mA (4-20mA) input connections

### 3.11 Measurement Voltage (0-1VDC) Input Terminals

Up to four differential measurement voltage inputs (0-1000 mV DC) are provided.

Connections for these voltage input terminals are provided in figure – 3.11 below.

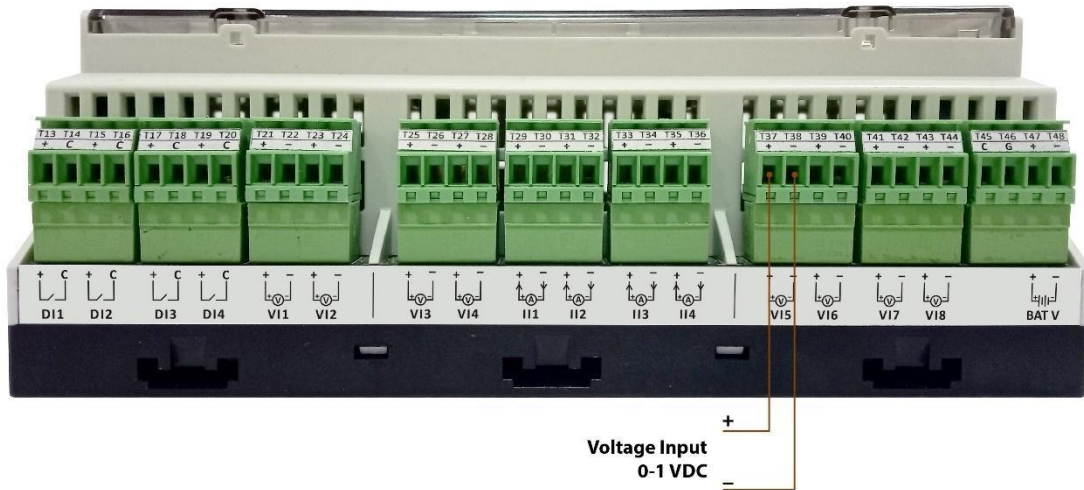

Figure-3.11: Measurement voltage (0-1VDC) input connections.

Connection details for voltage inputs are listed in table-3.11 below.

Terminal	Function	Remarks
T37	VI5+	Isolated measurement differential voltage inputs. ADC resolution – 24 bits
T38	VI5-	
T39	VI6+	Can be used for following functions/ sensors: Measure 0-1VDC differential signals.
T40	VI6-	
T41	VI7+	Pyranometers Solar irradiation transducers
T42	VI7-	
T43	VI8+	Wind speed Wind direction
T44	VI8-	
		Others. Configuration details for these voltage inputs are provided <a href="#">here</a> .

Table-3.11: MBLogger differential voltage (0-1VDC) input connections

### 3.12 Battery Voltage Measurement Terminals

System battery voltage can be measured via this input.

Connections for these voltage input terminals are provided in figure – 3.12 below.



Figure-3.12: Battery voltage input connections. (For Hardware version 3.11)

Connection details for battery voltage inputs are listed in table-3.12 below.

Terminal	Function	Remarks
T45	Bat V+	Isolated measurement battery voltage inputs. Reverse polarity protection. ADC resolution – 24 bits Can be used for measuring system battery voltage. Configuration details for these voltage inputs are provided <a href="#">here</a> .
T46	Bat V-	

Table-3.12 Battery voltage input connections

### 3.13 RTD Measurement Terminals

Three wire or four wire RTD (PT100 or PT1000) sensor can be connected to the data logger. Connections for RTD sensors are provided in figures – 3.13 below.



Figure-3.13.1: RTD input connections for three wire RTD sensor. (For Hardware version 5.00 and above)



Figure-3.13.1: RTD input connections for four wire RTD sensor. (For Hardware version 5.00 and above)

Connection details for four wire RTD inputs are listed in table-3.13 below.

Terminal	Function	Remarks
T45	W1	Three / Four wire RTD connections
T46	W2	
T47	W3	
T48	W4	

Table-3.13: RTD sensor connections.

## 4. MBLogger Display

MBLogger provides intelligent display and touch keys (capacitive) on front panel.

Protective hinged cover is provided over the display. This must be opened to get access to keys and display. If required, this protective cover can be sealed.

Two display options are provided based model selected.

- i) LED displays for digital inputs status and datalogger health.
  - ii) OLED display and keyboard for display of parameters and datalogger status. In this model LED display for digital inputs status and datalogger health is also provided.
- These displays turn OFF after configured time to save power. The displays are turned ON again if any of the keys is touched. See here on configuration of power save mode.

**Note:**

**Some of the OLED images have been edited for better visualization.**

### 4.1 Status LED Display

Status LED display are provided as shown in figure 4.1 below.

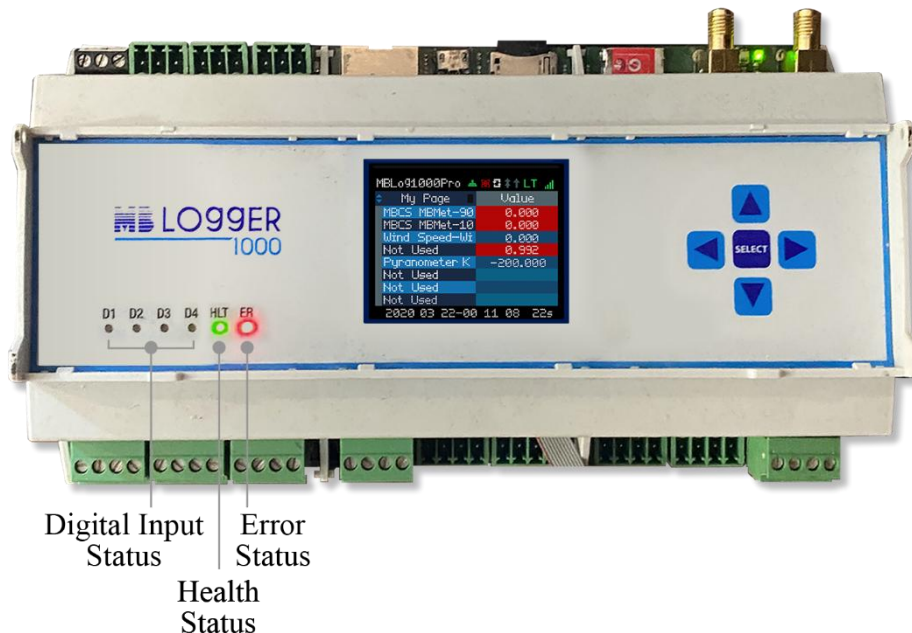

Figure-4.1: Status LED display

Details of these LED are listed in table-4.1 below.

LED	Function	Remarks
D1	Digital Input-1 Status	Status of digital inputs.
D2	Digital Input-2 Status	For status inputs: LED will be ON if inputs are connected and OFF if the input is open. For pulse input: LED will flash if pulses exist at the input. LED will be OFF if pulses do not exist at the input. For model with keys- the LED's will go off after set power save time. The LED's will ON again if any key is touched.
D3	Digital Input-3 Status	
D4	Digital Input-4 Status	
HLT	Datalogger health LED	
ERR	Datalogger Error LED	This LED will be ON if any hardware fault is detected in the datalogger. Details of faults can be viewed via OLED (if available) or embedded webserver.

Table-4.1: Status LED

## 4.2 Datalogger Operation Keys

Touch keys are provided on selected models of MBLogger. These keys are used for navigation and selection of parameters to be displayed on OLED.

If the OLED goes OFF after set time (power save mode), the same will be turned ON if any of the keys is touched.

Key details are shown in figure 4.2 below.

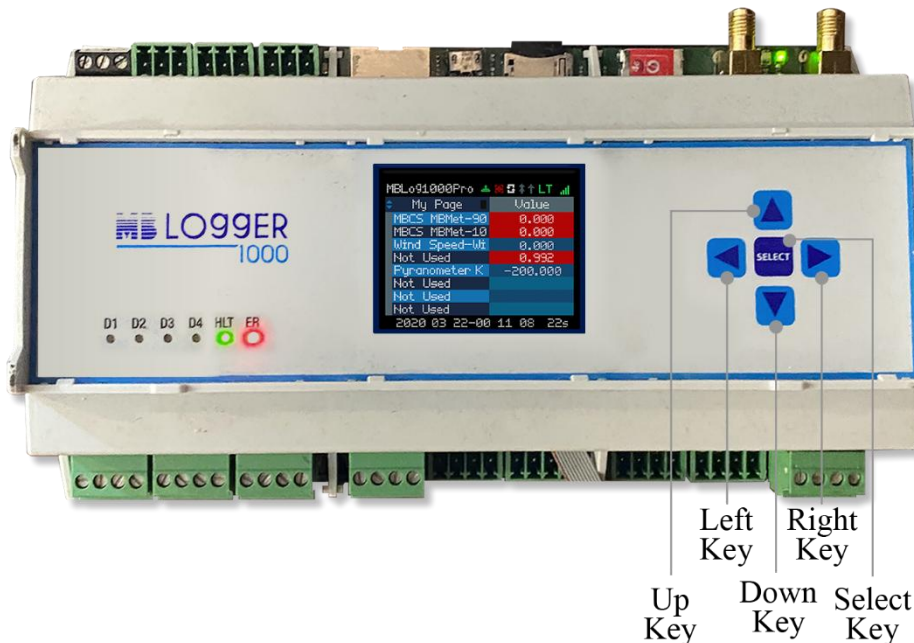

Figure-4.2: Datalogger keys

Operation of these keys are listed in table-4.2 below.





Key	Function	Remarks	
	Select	Turn on the display	No key operation will be performed.
	Right Key	Select between the following widgets: Parameter Source Parameter Attribute Select Parameters	Selected widget will scroll between the three options. The active widget will be highlighted.
	Left Key		
	Up Key	Select options available for the selected widget	Options available will scroll as the Up or Down key is pressed.
	Down Key		

Table-4.2: Datalogger keys

The above operations will be clearer on reading the section below on OLED operation.

### 4.3 Datalogger OLED

Highly efficient OLED is provided on selected model of MBLogger. OLED with touch keys enable operator to do the following:

- i) View operating status of network, modem, ftp and SNTP clients.
- ii) View measurement parameters from all inputs of the datalogger.
- iii) View parameters read from all devices and sensors connected to datalogger.
- iv) View MyPage parameters.
- v) View datalogger operation and fault messages.
- vi) Read datalogger time.

If power save mode is enabled, OLED will go off after set time (if no key is touched). OLED will turn on again on touching any key. Details of OLED are shown in figure 4.3 below.

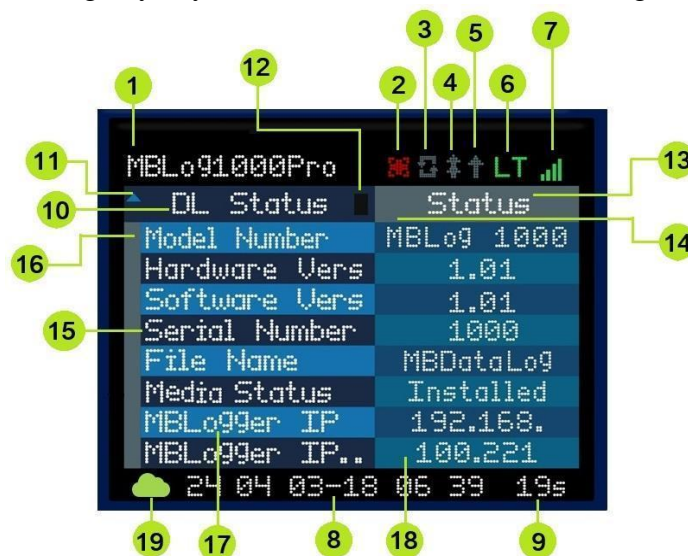







Figure-4.3: Datalogger OLED

Details of OLED widgets are provided in table-4.3 below.

Widget	Function	Remarks
W1	Datalogger model	Model of the datalogger
W2	 Network Gateway status	Dark grey – network gateway is not configured. <b>White</b> if the network gateway has been configured. Red if the network gateway is not reachable. Green if network gateway operation is OK.
W3	 SNTP client status	Dark grey – SNTP client is not configured. <b>White</b> if SNTP client has been configured. Red– if SNTP client fails to synchronise datalogger time. Green – if SNTP client operation is OK.
W4	 FTP client-2 status	Dark grey – if FTP client-2 is not configured. Red if FTP client-2 operation fails. Green if FTP client-2 operation is OK.
W5	 FTP client-1 status	Dark grey – if FTP client-1 is not configured. Red if FTP client-1 operation fails. Green if FTP client-1 operation is OK.
W6	 Modem connection status	No- No connection GS – GSM GP – GPRS ED – Edge LT – LTE
W7	 Cellular signal strength	Dark grey – if signal not found Green bars to display signal strength
W8	Datalogger Date and Time	Date and Time will be updated from the datalogger RTC in format YY MM DD-HH MM SS.
W9	Power saving display on remaining time (sec)	Time in seconds will count down. The time will be reset to configured value if any key is touched. Status LED's and OLED will be put Off when the time reaches 0.
W10	Selected Parameter Source	Use 'Right' or 'Left' key to select this widget. This widget will be highlighted if selected. Use Up or Down keys to select from the following parameter sources: Datalogger 'Status'- status of datalogger resource. 'MyPage' Parameters 'DL Message' – data logger messages 'AI mA' - measured mA inputs* 'AI V' – measured voltage inputs (0-10V)* 'AI mV' – measured voltage inputs (0-1V)* 'AI Vbat' - battery voltage* ) 'RTD' – PT100 or PT1000 input* 'DI' – Digital inputs* 'S1_485_IED1' - All IED connected and configured on serial port -1 RS485 will be listed*



		<p>‘S2_485_IED1’- All IED connected and configured on serial port -2 RS485 will be listed*</p> <p>‘S2_232_IED1’- IED connected and configured on serial port -2 RS232 will be listed*</p> <p>)‘ETH_IED1’- All IED connected and configured on ETH port will be listed*</p> <p>) Albedo Ratio*</p> <p>Today Solar Energy*</p>
W11	Up-Down arrows will display available options for Up or down keys for selection of parameter source	Use up or down key to select the parameter source
W12	Communication Status of selected parameter source	<p>Display communication status of the selected parameters source if it is connected to any serial or ETH port.</p> <p> Not applicable</p> <p> Communication with sensor / IED is OK</p> <p> Communication with sensor / IED has failed</p>
W13	Select parameter attribute for display	<p>Use ‘Right’ or ‘Left’ key to select this widget. This widget will be highlighted if selected.</p> <p>Use up and down keys to select parameter attribute to be displayed.</p>
W14	Up-Down arrows will display available options for Up or down keys for selection of parameter attribute	Use up or down key to select the parameter attribute for display
W15	Parameter list scroll	<p>Use ‘Right’ or ‘Left’ key to select this widget. This widget will be highlighted if selected.</p>
W16	Up-Down arrows will display available options for Up or down keys for parameter scroll	Use up or down key to scroll from the list of parameters from the selected source
W17	Selected Parameters Names	<p>Eight parameters are displayed at one time on the OLED.</p> <p>Parameter names from selected source (W10) and scrolled (W15) will be displayed.</p>
W18	Selected parameter attribute values	Selected parameter attribute (W14) value will be displayed.
W19	Cloud Connection Status	<p>Dark grey – if IOT is not configured.</p> <p>Red if FTP IOT operation fails.</p> <p>Green if IOT operation is OK.</p>

Table-4.3: OLED Widgets

Notes:

- i) \* : This option will be provided only if any of the input is configured. Inputs and IED which are not enabled and configured will not be listed in parameter source options.

## 4.4 OLED Power On

OLED will display welcome message at datalogger power 'On' time as shown in figure-4.4 below.



Figure-4.4: OLED welcome message

Normal display will resume normal operation when the datalogger testing is over.

## 4.5 Datalogger Status Display

Use W10 to select 'Status' to view datalogger status. Datalogger status will be displayed as shown in figure- 4.5 below.

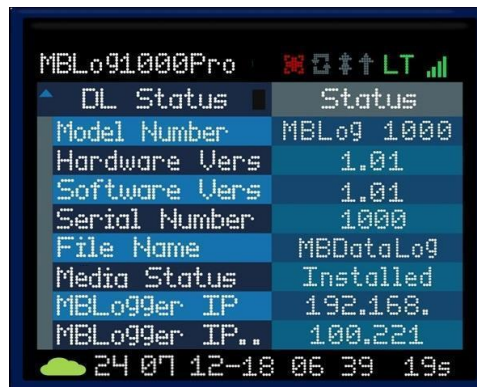

Figure-4.5: Datalogger status

Details of attributes available are listed in table-4.5 below.

Attribute	Description	Remarks
Status	Status of data logger resource	Status of data logger resources shall be displayed

Table-4.5: Datalogger status parameter attribute

## 4.6 MyPage Parameters Display

Use W10 to select 'MyPage' to view values of parameters configured for "MyPage". These parameters will be displayed as shown in figure- 4.6 below.



Figure-4.6: MyPage Parameters

Use W15 to scroll the parameter list.

Use W13 to select parameter attribute for display.

Details of attributes available are listed in table-4.6 below.

Attribute	Description	Remarks
Value	Parameter Value	Status of data logger resources shall be displayed
Val Min	Parameter minimum value	These values are calculated based on block time configured for the parameter.
Val Avg	Parameter average value	
Val Max	Parameter maximum value	
Val SD	Parameter standard deviation – This value will be displayed if its calculation enabled.	
Val Int	Parameter integrated value – This value will be displayed if its calculation enabled.	

Table-4.6: MyPage parameter attributes

## 4.7 MBLogger Message Display

Use W10 to select 'DL Message' to view logged datalogger messages. Datalogger messages will be displayed as shown in figure- 4.7 below.



Figure-4.7: Datalogger messages

Use W15 to scroll the datalogger message list.

Use W13 to select datalogger message attribute for display.

Details of attributes available are listed in table-4.7 below.

Attribute	Description	Remarks
Message	Datalogger message	Hardware faults will be displayed in red.

Code	Code for the datalogger message	Display message code.
Date	Message logged date	
Time	Message logged time	

Table-4.7: Datalogger messages attributes

## 4.8 Analogue Input – mA Value Display

Use W10 to select 'AI mA' to view values of measured mA channels. This page will display enabled and configured mA input channels as shown in figure- 4.8 below.



Figure-4.8: Measured mA channel values

Use W13 to select parameter attribute for display.

Details of attributes available are listed in table-4.8 below.

Attribute	Description	Remarks
Value	Parameter Value	Status of data logger resources shall be displayed
Val Min	Parameter minimum value	These values are calculated based on block time configured for the parameter.
Val Avg	Parameter average value	
Val Max	Parameter maximum value	
Val SD	Parameter standard deviation – This value will be displayed if its calculation enabled.	
Val Int	Parameter integrated value – This value will be displayed if its calculation enabled.	

Table-4.8: Measured mA attributes

## 4.9 Analogue Input – Voltage Value Display

Use W10 to select 'AI V' to view values of measured voltage (0-10V) channels. This page will display enabled and configured voltage input (010V) channels as shown in figure- 4.9 below.



Figure-4.9: Measured voltage channel values

Use W13 to select parameter attribute for display.

Details of attributes available are listed in table-4.9 below.

Attribute	Description	Remarks
Value	Parameter Value	Status of data logger resources shall be displayed
Val Min	Parameter minimum value	These values are calculated based on block time configured for the parameter.
Val Avg	Parameter average value	
Val Max	Parameter maximum value	
Val SD	Parameter standard deviation – This value will be displayed if its calculation enabled.	
Val Int	Parameter integrated value – This value will be displayed if its calculation enabled.	

Table-4.9: Measured voltage attributes

#### 4.10 Analogue Input – Milli Voltage Value Display

Use W10 to select ‘AI mV’ to view values of measured voltage (0-1V) channels. This page will display enabled and configured voltage input (0-1V) channels as shown in figure- 4.10 below.



Figure-4.10: Measured voltage channel values

Use W13 to select parameter attribute for display.

Details of attributes available are listed in table-4.10 below.

Attribute	Description	Remarks
Value	Parameter Value	Status of data logger resources shall be displayed
Val Min	Parameter minimum value	These values are calculated based on block time configured for the parameter.
Val Avg	Parameter average value	
Val Max	Parameter maximum value	
Val SD	Parameter standard deviation – This value will be displayed if its calculation enabled.	
Val Int	Parameter integrated value – This value will be displayed if its calculation enabled.	

Table-4.10: Measured voltage attributes

#### 4.11 Analogue Input – Battery Voltage Display

Use W10 to select ‘AI BatV’ to view values of measured system battery voltage. This page will display battery voltage if the same is available and is enabled as shown in figure- 4.11 below.



Figure-4.11: Measured battery voltage value

Use W13 to select parameter attribute for display. Details of attributes available are listed in table-4.11 below.

Attribute	Description	Remarks
Bat Volts	Battery voltage	Display battery voltage

Table-4.11: Measured battery voltage attribute

#### 4.12 Analogue Input – RTD Input Display

Use W10 to select ‘AI RTD’ to view values of measured RTD temperature. This page will display temperature if the same is available and is enabled as shown in figure- 4.12 below.



Figure-4.12: Measured RTD temperature value

Use W13 to select parameter attribute for display.

Details of attributes available are listed in table-4.12 below.

Attribute	Description	Remarks
RTD Temp	RTD temperature	Display RTD temperature

Table-4.12: Measured temperature attribute

### 4.13 Digital Inputs Status

Use W10 to select 'DI' to view status of digital input channels. This page will display status of enabled and configured digital inputs as shown in figure- 4.13 below.



Figure-4.13: Digital inputs status and values

Use W13 to select attribute for display.

Details of attributes available are listed in table-4.13 below.

Attribute	Description	Remarks
Status	Status of digital input	'ON' or 'OFF'
Calc Val	Accumulated and calculated value	Calculated as per configured constants. eg. for rain gauge or wind speed sensor inputs
Val Min	Parameter minimum value	These values are calculated based on block time configured for the parameter.
Val Avg	Parameter average value	
Val Max	Parameter maximum value	

Val SD	Parameter standard deviation – This value will be displayed if its calculation enabled.	
--------	---	--

Table-4.13: Digital inputs attributes

#### 4.14 Sensors and IED Parameters Display

Use W10 to select desired sensor or IED based on the port it is interfaced to. The sensor or IED will be listed only if it is enabled and configured.

Communication status of the selected IED shall be displayed via W12.

Selected sensor/ IED parameters will be displayed as shown in figure- 4.14 below.



Figure-4.14: Parameters from selected sensor/ IED

Use W15 to scroll the parameter list.

Use W13 to select parameter attribute for display.

Details of attributes available are listed in table-4.14 below.

Attribute	Description	Remarks
Value	Parameter Value	Parameter value. Invalid parameter values will be shown in red colour.
Val Min	Parameter minimum value	These values are calculated based on block time configured for the parameter. Invalid parameter values will be shown in red colour.
Val Avg	Parameter average value	
Val Max	Parameter maximum value	
Val SD	Parameter standard deviation – This value will be displayed if its calculation enabled.	
Val Int	Parameter integrated value – This value will be displayed if its calculation enabled.	

Table-4.14: Sensor/ IED parameter attributes

## 4.15 Plant Parameter Display

This display will be available only if the license for the function is added to the datalogger. Use W10 to select the page on the OLED display. Plant parameters will be displayed as shown in figure- 4.15 below.



Figure-4.15: Plant Parameters display

## 4.16 Albedo Parameter Display

Use W10 to select the Albedo parameter page on the OLED display.



Figure-4.16: Albedo ratio parameters display

## 4.17 Today Solar Energy Display

Use W10 to select the today solar energy page on the OLED display.



Figure-4.17: Today solar energy parameters display

## 5. Setting Default IP Address

Procedure for setting default IP address in the datalogger is provided below. This procedure should be followed only if IP address of the datalogger is not known. If datalogger IP address is known, use webserver in the datalogger to set the required IP address.

**This feature is available only in dataloggers having hardware version 3.1 and above.**

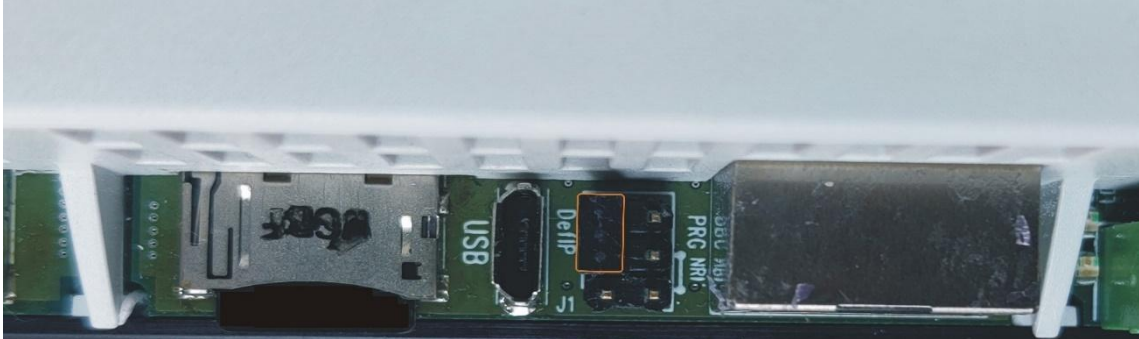

Figure -5.1: Jumpers for setting default IP address in the datalogger HW version 3.1.

1. For normal operation jumper DefIP shall be in open condition.
2. For setting default IP address short jumper DefIP for about two seconds.
3. Remove the DefIP jumper.
4. Wait for about five seconds.
5. Datalogger will restart with [default IP](#) address. Only default IP address and Subnet shall be set to default values.

Verify default IP address by using ping and / or logging in the datalogger webserver.

**This feature is available only in dataloggers having hardware version 5.1 and above.**



Figure -5.2: Dip Switches for setting default IP address in the datalogger HW version 5.1 and above.

1. For normal operation Dip switch DefIP shall be in OFF condition.
2. For setting default IP address shift switch (2 no.) position for about two seconds.
3. Again shift the switch position as previous.
4. Wait for about five seconds.
5. Datalogger will restart with [default IP](#) address. Only default IP address and Subnet shall be set to default values.
6. Verify default IP address by using ping and or logging in the datalogger webserver.

*Ensure that no devices have the same IP address in the same network. The network will fail and devices will not respond if more one device have same IP address.*

## 6. Embedded Webserver

---

MBLogger provides embedded webserver for configuration and diagnostics.

Following functionality is provided via the embedded webserver.

- i) Datalogger configuration.
- ii) Monitor measured parameters.
- iii) Download and delete logged files
- iv) User configuration.
- v) Datalogger diagnostic messages
- vi) Download datalogger diagnostic logs.
- vii) Dropdown list for section of pre-selected options.
- viii) Limit validation for configured parameter values.
- ix) Hoover (take cursor) over the parameter to get further details on the same.
- x) Details of not all parameters have been provided in this manual (to reduce the size). Further details can be obtained by using hoover over the parameter.
- xi) Auto configured parameters will not have editable configuration field.
- xii) Configuration of parameters not applicable will be disabled.
- xiii) Limits are displayed for parameters with limits (allowed minimum and maximum values). Default values are provided for most of the parameters.
- xiv) After editing any parameter click the cursor on any part of the screen. The parameter value is checked for errors and will be saved if there is no error. If any error is found, same will be indicated on right hand top corner of the screen. Wrong values will not be saved and menu option for the parameter will turn red till the wrong value is corrected.
- xv) All edited parameters will be marked till the same has not been committed.
- xvi) Page menu option for the parameter will be marked with 'E'. This mark will be provided at all hierarchy levels (upwards) till "MBLogger Configuration".
- xvii) All configuration of parameters will be saved on 'Commit' operation. Edit marks will also be removed from all edited parameters on 'Commit' operation being successful.

## 6.1 User Login

Use 'Chrome' to login to datalogger embedded web server.

Use datalogger IP (for first login – use datalogger default IP) to login. Following login screen shall be displayed as shown in figure-6.1 below.

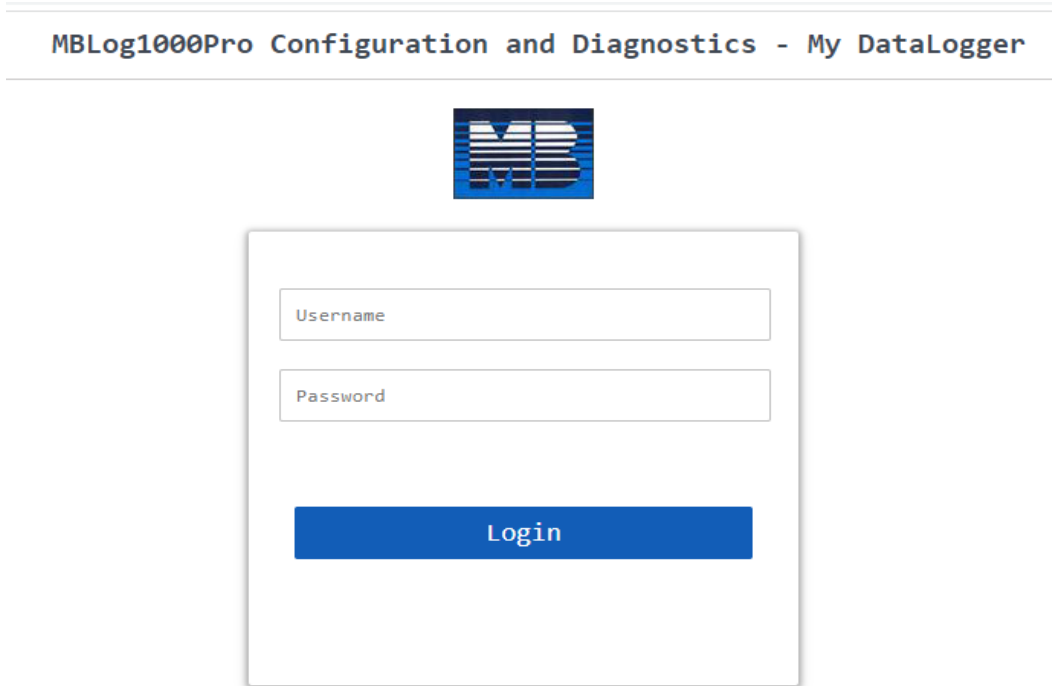

MBLog1000Pro Configuration and Diagnostics - My DataLogger

MB

Username

Password

Login

Figure-6.1: Datalogger login screen.

The login page shows datalogger model and device name, Device name can be configured as required. User login details are provided in table 6.1 below.

User Type	Default Password	User Rights
Viewer	'Viewer'	Rights to view configuration and view diagnostic information.
Operator	'Operator'	All rights for configuration, operation, and diagnostics.
Admin	'Admin'	All rights for configuration, operation, diagnostics, and user configuration.
Maint	Not allowed	Maintenance user is used during manufacturing only.

Table-6.1: User login details

It advisable that first login should be done by 'Admin' and then other users and their passwords should be configured.

## 6.2 Welcome Page

Upon successful user login, welcome page as shown in figure-6.2 is displayed.

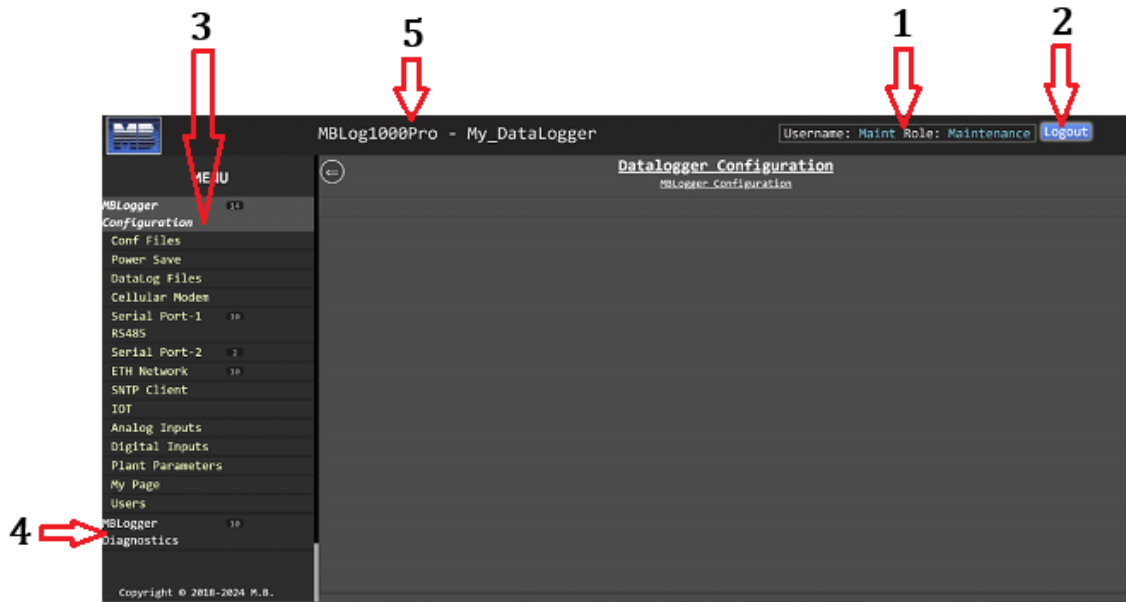

Figure-6.2: User login welcome page.

The welcome page is self-explanatory, all the information required for configuration of the datalogger is provided on the page.

Details of welcome page are provided in table 6.2 below.

Object No	Description	Remarks
1	Username and role	Displays logged username and role.
2	'Logout'	Button for user logout. User will be automatically logged out if there is no keyboard or mouse activity for three minutes. User will be warned about this by warning sign on right hand top corner of the page. User can do any keyboard or mouse activity to reset the logout timer.
3	MBDataLogger Configuration	Left click on this menu option to configure the datalogger. Menu options below will enable configuration all features of the datalogger. Left click on any menu option to configure the same.
4	Datalogger Diagnostics	Left click on this menu option to view datalogger diagnostics menu.
5	Datalogger device name	This name can be configured as required.

Table-6.2: Datalogger welcome page

### Note:

If the user closes the webpage without logging out, user will have to wait for about three minutes prior to next login.

## 6.3 Datalogger Configuration Files

Datalogger configuration files can be saved in the datalogger SD card.

Left click on menu option ‘Configuration Files’ to view the datalogger configuration files saved in the SD card shown in figure-6.3 below.

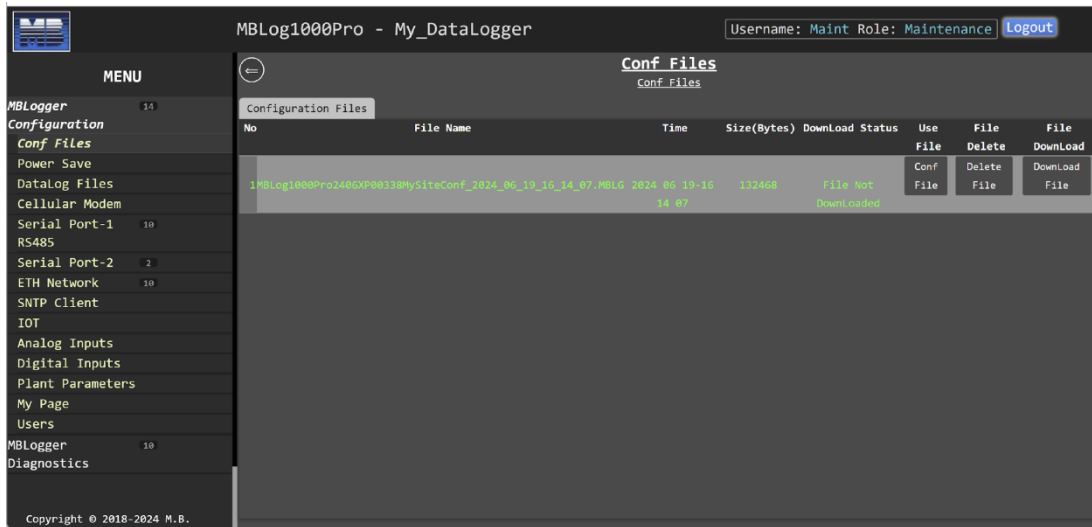

Figure-6.3: Datalogger configuration files.

Selected menu option shall be highlighted.

Operations available for datalogger configuration files are shown in table 6.3.1 below.

Sr. No	Operation	Action	Remarks
1	Save present datalogger configuration file	Right Click menu “Configuration Files” and select option “Save Present Configuration File” by left clicking on the option.	Datalogger configuration file will be saved in the SD Card and will be displayed in the list of configuration files saved. File name will have model details, serial number and site name with date and time details.
2	Restore configuration	Right Click menu “Configuration Files” and select option “Restore Configuration” by left clicking on the option.	Datalogger configuration shall be restored in webserver. All edited ‘E’ parameters will be reverted to values and status as per current configuration of datalogger. This will be confirmed by removal of ‘E’ mark from all edited parameters.
3	Upload Configuration File	Right Click menu “Configuration Files” and select option “Upload Configuration File” by left clicking on the option.	Datalogger configuration file shall be uploaded from the selected directory in PC. Selected file shall be verified and will be uploaded only if the file all verification procedures. Files with same name will not be Uploaded.

Table-6.3.1: Datalogger configuration file operations

Options available for saved datalogger configuration files are shown in table 6.3.2 below.

Sr. No	Operation	Action	Remarks
1	Download File	Click on button “Download File” for the file to be downloaded.	Selected file will be downloaded on connect PC/ Laptop. File “Download Status” will show “File Downloaded”.
2	Delete File	Click on button “Delete File” for the file to be deleted.	The file will be deleted and removed from the list. Deleted files cannot be restored.
3	Use file for configuration	Click on button “Conf File” for using the file for configuration.	The file will be validated. If validation is OK, datalogger configuration parameters will be displayed as edited parameters. Parameters which do not match with present configuration shall be marked with ‘E’. Use ‘Device Commit’ operation to configure the datalogger with the selected file.

Table-6.3.2: Operations for saved configuration files

## 6.4 Configure – Power Save

Left click on menu option ‘Power Save’ to configure device location and OLED power save parameters as shown in figure-6.4 below.

Selected menu option shall be highlighted.

Select the required tab to configure the tab parameters. Selected tab shall be highlighted.

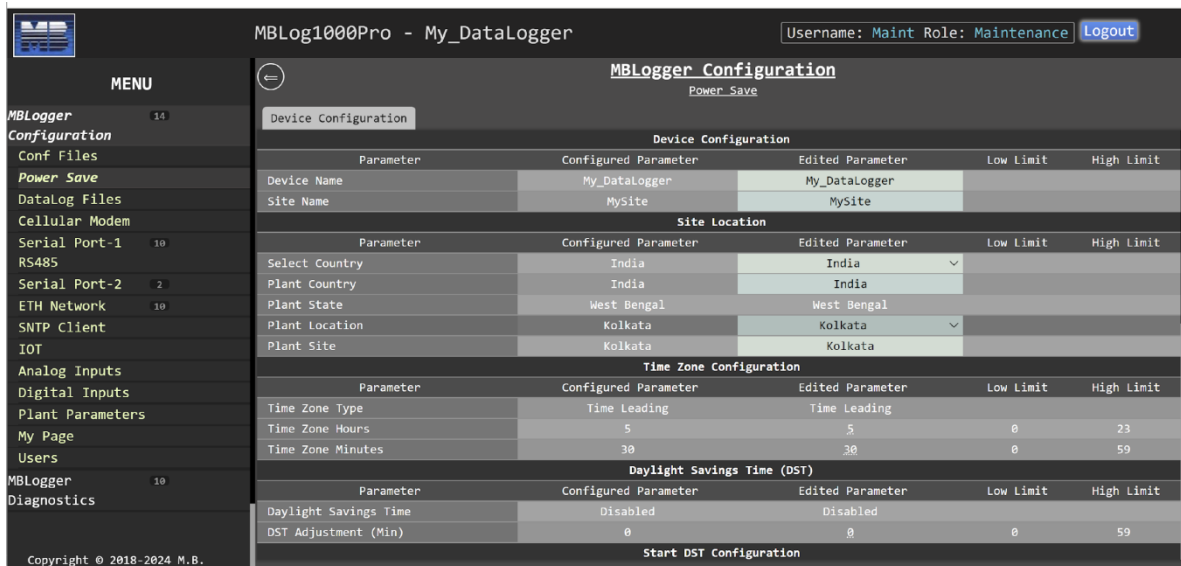

Figure-6.4.1: Configuration of datalogger name and site parameters.



Figure-6.4.2: Configuration of datalogger DST parameters.



Figure-6.4.3: Configuration of datalogger OLED power save parameters.

Details of the page are provided in table 6.4 below.

Sr. No	Parameter	Description	Remarks
<b>Device Configuration</b>			
1	Device Name	Device name.	Can be used to identify the device. This name will be displayed while logging in the device and on each web page.
2	Site Name	Site Name	Site name is used to identify the site. Site name shall be used while saving configuration files and preparing device status and value reports.
<b>Site Location</b>			
1	Select Country	Country Name	Select from dropdown list
2	Plant Country		Manual entry of country if not found in the dropdown list.

3	Plant State		Select state if India is selected
4	Plant Location		Select from dropdown list
5	Plant Site		Add plant site
<b>Time Zone Configuration</b>			
1	Time Zone Type	Set site time zone	Select leading or lagging time zone.
2	Time zone hours		Set time zone hours and minutes to added (or subtracted from GMT). This will be used for time synchronisation.
3	Time zone minutes		
3	OLED Power Save Mode(i)	Enable/ Disable power save mode.	In enabled OLED and LED will be Off after the set time if there no key activity on the front panel.
<b>Day Light Saving Time</b>			
1	Daylight Savine Time		Enabled or disabled
2	DST Adjustment (min)		Time in minutes to be adjusted for DST
<b>Start DST Configuration</b>			
1	Start DST Month		DST Start date and time
2	Start DST Date		
3	Start DST Hour		
4	Start DST Minutes		
<b>End DST Configuration</b>			
1	End DST Month		DST End date and time
2	End DST Date		
3	End DST Hour		
4	End DST Minutes		
<b>Site Latitude</b>			
1	Plant Hemisphere	North or South	Select plant hemisphere
2	Plant Site Latitude		Enter plant latitude. <i>Sun rise and set times will be calculated based on plant location.</i>
<b>Site Longitude</b>			
1	Plant Meridian	East or West	Select plant meridian
2	Plant Site Longitude		Enter plant logitude. <i>Sun rise and set times will be calculated based on plant location.</i>
<b>Data Logger Display Operation</b>			
1	OLED On Time (sec)(i)	Select OLED on time in seconds	Limits for this parameter are displayed as ‘Low Limit’ and ‘High Limit’. Error will be displayed if out of bound parameter value is entered.
2	Set Device Time	Left click on the button ‘Set Device Time’ to	On successful operation, current time will be displayed.

		synchronize the datalogger time with PC time	
<b>Set Datalogger Time</b>			
1	Set Device Time		Click 'Set Device Time' to synchronise device time to PC time.

Table-6.4: Configuration – power save parameters.

Note:

- i) Applicable only for models with OLED.

## 6.5 Configure – Datalog Files

All logged files are saved in SD memory card. The card should be formatted with 'FAT32' format before being inserted in SD card holder.

SD card should not be removed or inserted while the datalogger is powered On and in operation.

Disconnect power to data logger prior to inserting or removing the SD card.

Files are saved with .csv extension with date and time.

Details of data log directories are provided in table 6.5.1 below:

Sr. No	Directory Name	Description	Remarks
1	'DirDataLogDay'	Stores day log files	Configure operation of day log files.
2	'DirDataLogRFT1'	Stores files for remote file server 1	Configure operation of files for remote file server 1.
3	'DirDataLogRFT2'	Stores files for remote file server 2	Configure operation of files for remote file server 2.

Table-6.5: Data log file directories

Datalogger will automatically create missing directories on the SD card.

Parameter values and its attributes will be saved in the data log files if the parameter is configured for datalogging (refer to configuration of individual parameter for more details).

Left click on menu option 'Datalog Files' to configure file operation as shown in figure-6.5 below.

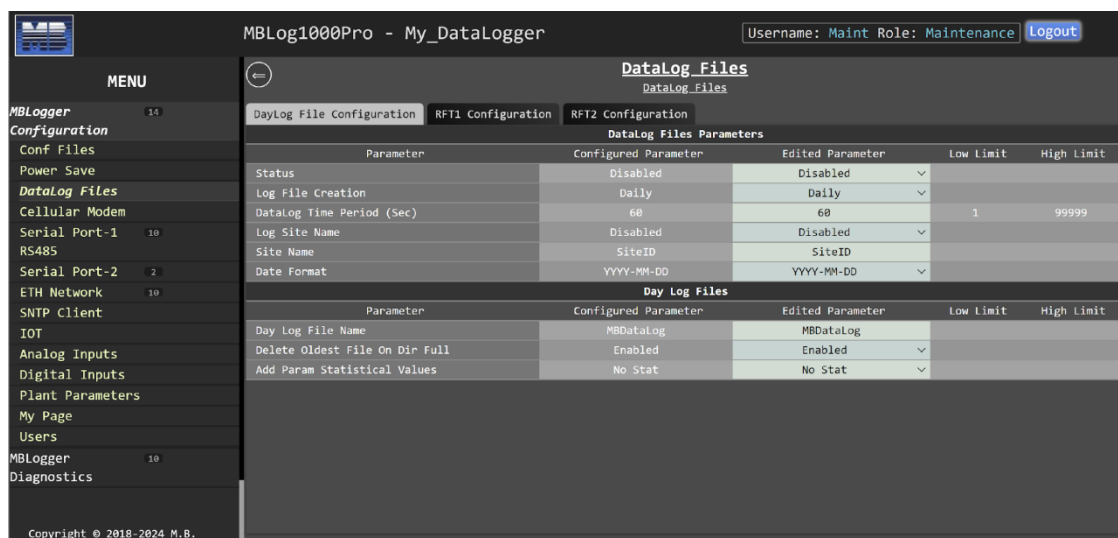

Figure-6.5: Configuration of data log file operations.

For parameters having pre-selected options, available options are provided as drop-down list.

Following log files can be configured:

- i) 'Day Log File Configuration': Day data log file.
- ii) 'RFT1 Configuration': Remote file transfer-1 configuration
- iii) 'RFT2 Configuration': Remote file transfer-2 configuration
- iv)

### 6.5.1 Log File Configuration:

Configuration of log file is shown in figure 6.5.1 below.

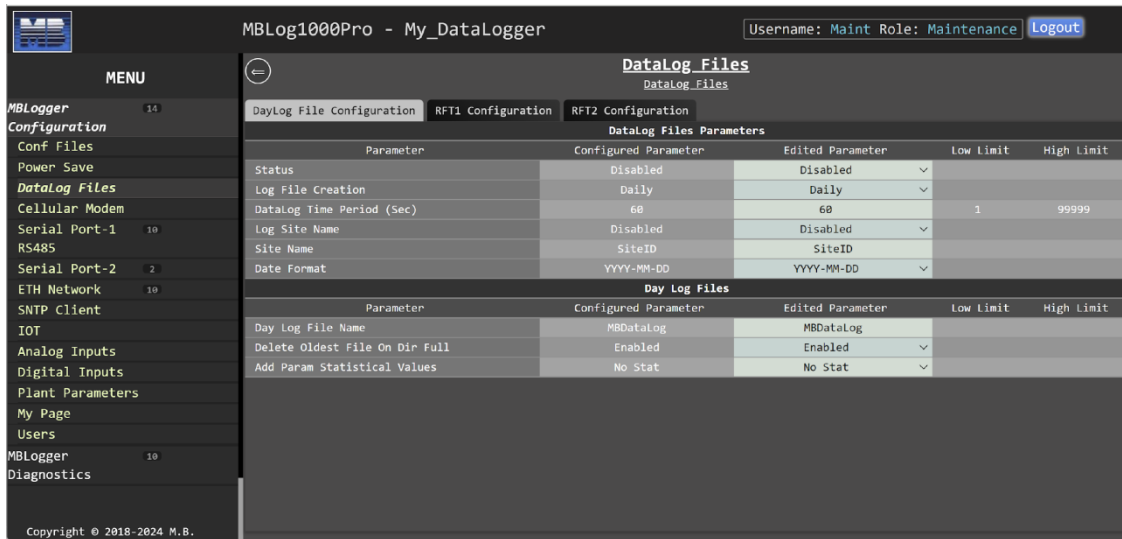

Figure-6.5.1: Log file Configuration

Details of the configuration parameters are provided in table 6.5.1 below. For details on other parameters use hover feature of the webpage. Take cursor on the parameter object on the page and further information will be displayed for the parameter.

Sr. No	Parameter	Description	Remarks
<b>Data log File Parameters</b>			
1	Status	Enable / Disable data log operation	If disabled, data log operation will be disabled
2	Log file creation	Select 'Daily' or 'Monthly'	Select time period for new log file creation. 'Daily': New log file will be created each day. 'Month': New log file will be created each month. <i>Select 'Month' for longer duration log files.</i>
3	Data Log Time Period (sec)	Time period for logging data in seconds	
4	Log Site Name		Site name will be logged if enabled.
5	Site Name		Enter site name to be logged.
6	Date Format		Select date format to be used for data logging. Available formats: YYYY-MM-DD, DD-MM-YYYY
<b>Log File Configuration</b>			

3	Day Log File Name	Provide required data log file name	Day data log files will be saved with this name suffixed by ‘_Day’. Time in ‘YYY_MM_DD’ format will be added to the file name. e.g. ‘MBDataLog_Day_2020_12_06’
4	Delete Oldest File on Directory Full	If the directory is full – oldest file is deleted so that new file can be added.	<b>Disabled:</b> Data logging will stop if the directory is full. <b>Enabled:</b> Data logging will continue after deleting the oldest file in the directory.
5	Add Param Statistical Values	Option to add parameter statistical values to log.	<b>Stat:</b> Parameters statistical values – average, maximum, minimum and standard deviation are added to the log. <b>No Stat:</b> Only parameter values are logged.

Table-6.5.1: Configuration –data log file operation

### 6.5.2 Remote File Transfer Configuration:

Remote file transfer can be configured via tabs – ‘RFT1 Configuration’ and ‘RFT2 Configuration’. Configuration page is shown in figure 6.5.2 below.

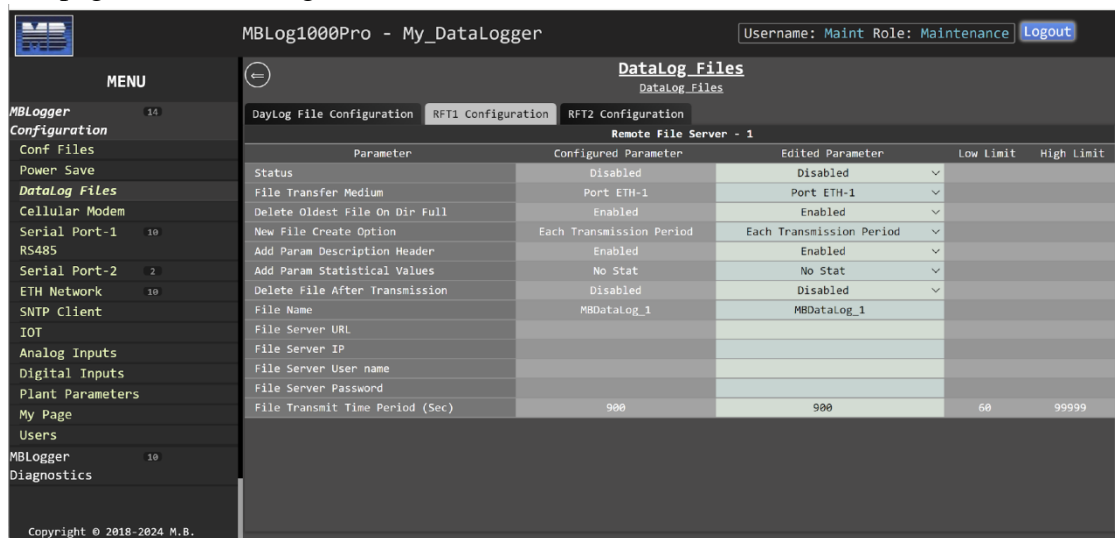

Table-6.5.2: Configuration – remote file transfer operation

Details on file parameters on the are provided in table 6.5.2.1 below.

Sr. No	Parameter	Description	Remarks
1	Status	Enabled / Disabled data log operation	If disabled, data log operation will be disabled
2	File Transfer Medium	Select Port ETH or Cellular Modem	Logged files will be transmitted via the selected medium. Note: If cellular modem is selected as medium and the modem operation fails – file transfer will be attempted via ETH port (if the port is connected and the gateway connection is OK).
3	Delete Oldest File on Directory Full	If the directory is full – oldest file is deleted so that new file can be added.	<b>Disabled:</b> Data logging will stop if the directory is full. <b>Enabled:</b> Data logging will continue after deleting the oldest file in the directory.

4	New File Create Option	Select from 'Each Day' or 'Each Transmission Period'	<b>Each Day:</b> New data log file will be created as start of each day. <b>Each Transmission Period:</b> New data log file will be created at start of each file transmission time period.
5	Add Param Description Header	Enabled or disabled	If enabled, parameter description header will be added to the file
6	Add Param Statistical Values	Enabled or disabled	<b>Enabled:</b> Calculated statistical values – minimum, maximum, average, standard deviation, and integrated value shall be added to the log (as per parameter configuration). <b>Disabled:</b> Only parameter value shall be added to the log.
7	Delete File after Transmission	Enabled or disabled	<b>Enabled:</b> Data log file shall be deleted after successful transmission. <b>Disabled:</b> Data log file will not be deleted after transmission.
8	File Name	Provide required data log file name	Data log files will be saved with this name. Time in 'YYYY_MM_DD_HH_MM' format will be added to the file name. e.g. 'MBDataLog_2020_03_15_15_45'
9	File Server URL	URL for the file server	Data logger shall resolve the URL to get the file server IP address.
10	File server IP	IP address for the file server	
11	File server Username	Username for the client	
12	File server Password	Password for the client	FTP client will use the configured username and password to connect to the file server.
13	File Transmit Time Period (sec)	File transmit time in seconds	Logged file will be transmitted after this time.

Table-6.5.2.1: Configuration – remote file transfer operation

**Notes:**

i) If 'Modem' is selected media for file transfer, and it fails, file transfer shall be tried via ETH port (if the link to configured gateway is OK).

ii)

Details for parameter descriptor header with statistical values are provided in table 6.5.2.2 below.

Sr. No	Column	Description	Remarks
1	Date	Date of logging	YYYY.MM.DD
2	Time	Time of logging	HH.MM.SS
3	Parameter Quality	Parameter Description_Qua	= '0' for bad quality = '1' for good quality
4	Parameter Value	Parameter Description_Val.	Value in float

		For sensors and IED connected to datalogger ports refer to table – 6.5.2.3.	
5	Parameter minimum Value	Parameter Description_Min	Minimum value in float
6	Parameter maximum Value	Parameter Description_Max	Maximum value in float
7	Parameter average Value	Parameter Description_Avg	Average value in float
8	Parameter standard deviation Value	Parameter Description_SD	Standard Deviation value in float. This value shall be provided if its calculation is enabled.
9	Parameter Integrated Value	Parameter Description_Int	Integrated value in float. This value shall be provided if its calculation is enabled.
10	Next parameter quality		

Table-6.5.2.2: Parameter descriptor header with statistical values

Details for parameter descriptor header without statistical values are provided in table 6.5.2.3 below.

Sr. No	Column	Description	Remarks
1	Date	Date of logging	YYYY.MM.DD
2	Time	Time of logging	HH.MM.SS
3	Parameter Value	Parameter Description Val. For sensors and IED connected to datalogger ports refer to table – 6.5.2.3.	Value in float
4	Next parameter value		

Table-6.5.2.3: Parameter descriptor header without statistical values

Parameter description for sensors and IED connected to datalogger communication ports is provided in table 6.5.2.4 below.

Sr. No	Parameter	Header
1	Sensor / IED description	First ten characters of Sensor or IED description
2	Parameter description	First ten characters of parameters description
3	Parameter Attribute	_Qua, _Val, _Min, _Max, _Avg, _SD or _Int

Table-6.5.2.4: Parameter descriptor for sensor and IED connected to datalogger communication ports.

**Example:**

IED Description: Satec PM130EH

Parameter Description: Voltage V1

Parameter Attribute: Value

Header for the parameter: Satec PM13\_Voltage V1\_Val

## 6.6 Configure – Cellular Modem

Use micro-SIM with 4G service.

GPS will be disabled if device modem is used file transfer or IOT services. In this configuration modem will operate in ‘PPP’ mode only and GPS will not be used for location or time synchronization. SNTP service should be used in this case for time synchronization.

GPS can be used if IOT and file transfer services are used via ETH port.

GPS can be used even if the SIM is not installed subject to above criteria.

Left click on menu option ‘Cellular Modem’ to configure internal modem operation as shown in figure-6.6 below.

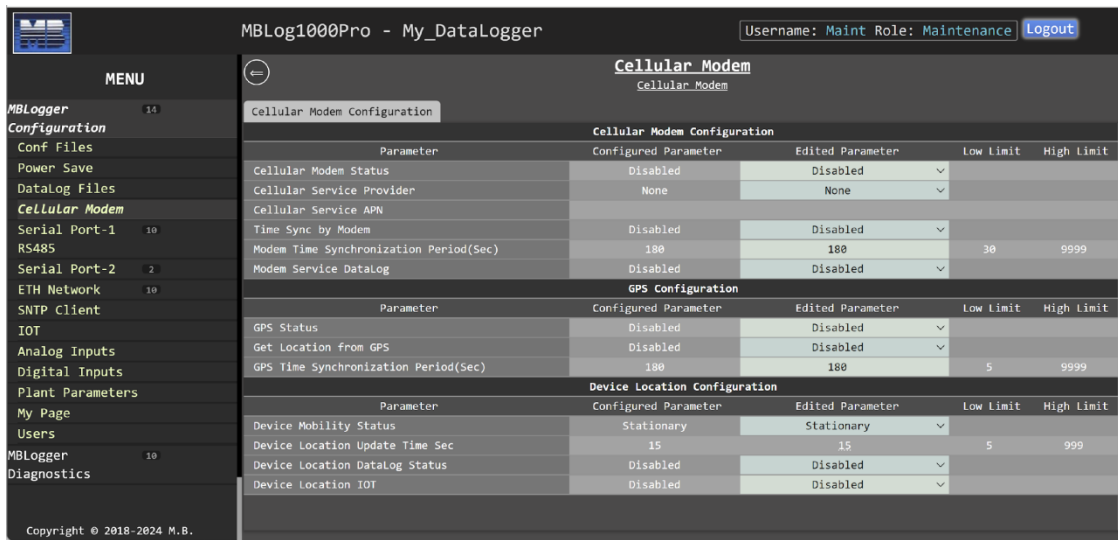

Figure-6.6: Configuration of internal cellular modem.

Configuration details of modem parameters on the page are provided in table 6.6 below.

Sr. No	Parameter	Description	Remarks
<b>Cellular Modem Configuration</b>			
1	Cellular Modem Status		Enable or disable.
2	Cellular Service Provider	Select cellular service provider	Select the service provider from the dropdown list. If ‘None’ is selected, modem operation will be disabled.
3	Cellular service APN	APN for the service provider	APN will be auto configured based on the selected service provider.
4	Time Sync by Modem	Enable/ Disable	Device time shall be synchronised via network service provider.
5	Modem time Synchronisation Period (sec)	Time period for time synchronisation via modem	
6	Modem Service Data log	Modem network status will be logged	Enable or disable.

Table-6.6: Configuration – datalogger modem

## 6.7 Configure – GPS

GPS is available via in-built modem. GPS will work even if SIM is not installed.

GPS will be disabled if file transfer or IOT services are used via device modem. In this configuration modem will operate in ‘PPP’ mode only and GPS will not be used. SNTP service should be used in this case for time synchronization.

GPS can be used if IOT and file transfer services are used via ETH port.

GPS can be used even if the SIM is not installed subject to above criteria.

GPS configuration is shown in figure -6.7 below.

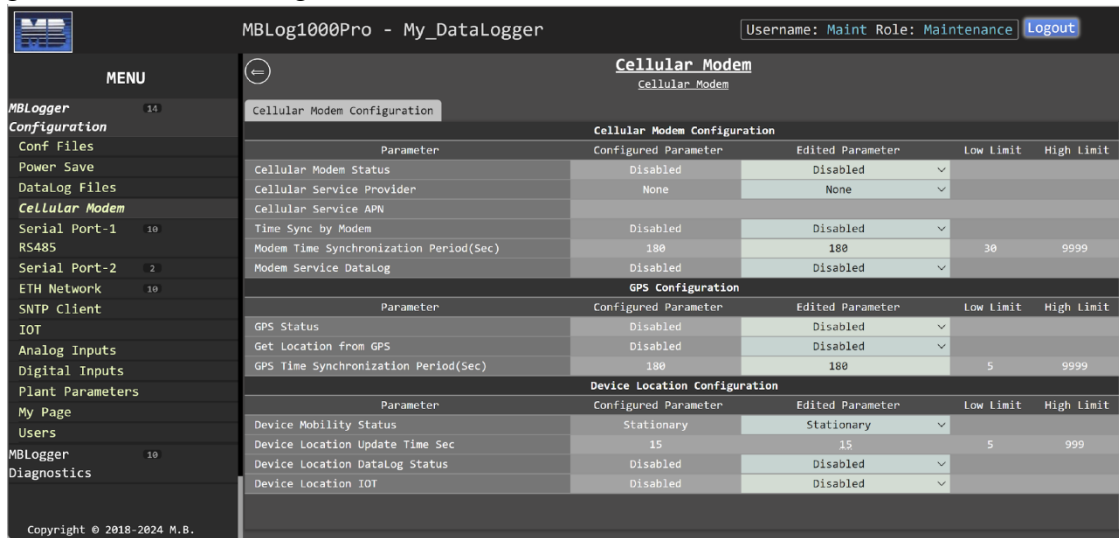

Figure-6.7: Configuration of GPS

Configuration details of GPS parameters on the page are provided in table 6.7 below.

Sr. No	Parameter	Description	Remarks
1	GPS Status	Enable/ Disable	GPS can be enabled only if modem is installed and enabled
2	Get location from GPS	Use GPS service to get device location.	Enable or disable.
3	GPS Time Synchronization Period (Sec)	APN for the service provider	APN will be auto configured based on the selected service provider.

Table-6.7: Configuration – GPS

## 6.8 Configure – Device Location

Device location can be determined via GPS.

Location configuration is shown in figure -6.8 below.

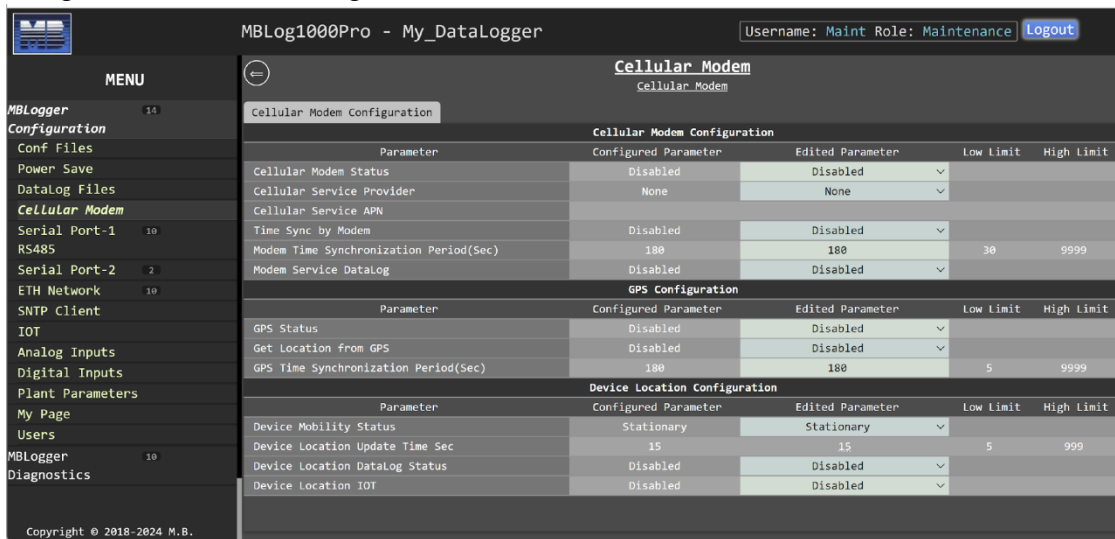

Figure-6.8: Configuration – Device Location.

Configuration details of Device Location parameters on the page are provided in table 6.8 below.

Sr. No	Parameter	Description	Remarks
1	Device Mobility Status	Stationary of Mobile	Select type of device installation
2	Device Location Update Time (Sec)	Set time for updating device location.	Will be enabled only for Mobile devices.
3	Device Location Data Log Status	Enable/ Disable	Enable if device location is to be logged.
4	Device Location IOT	Device location will be sent via IOT	Enable or disable.

Table-6.8: Configuration – Device location

## 6.9 Configure – Serial Port-1 (RS485)

Serial port -1 (RS485) can be used as MODBUS RTU Master or MODBUS RTU Slave.

MODBUS communication messages can be logged for diagnostics by MBCS diagnostics team.

MODBUS slave devices can be connected to this port. See here configuration details for MODBUS slave devices.

Use low capacitance, twisted pair and shielded cable for connection of sensors and IED's to this port.

Left click on menu option 'Serial Port-1 RS485' to configure this port as shown in figure-6.9 below.

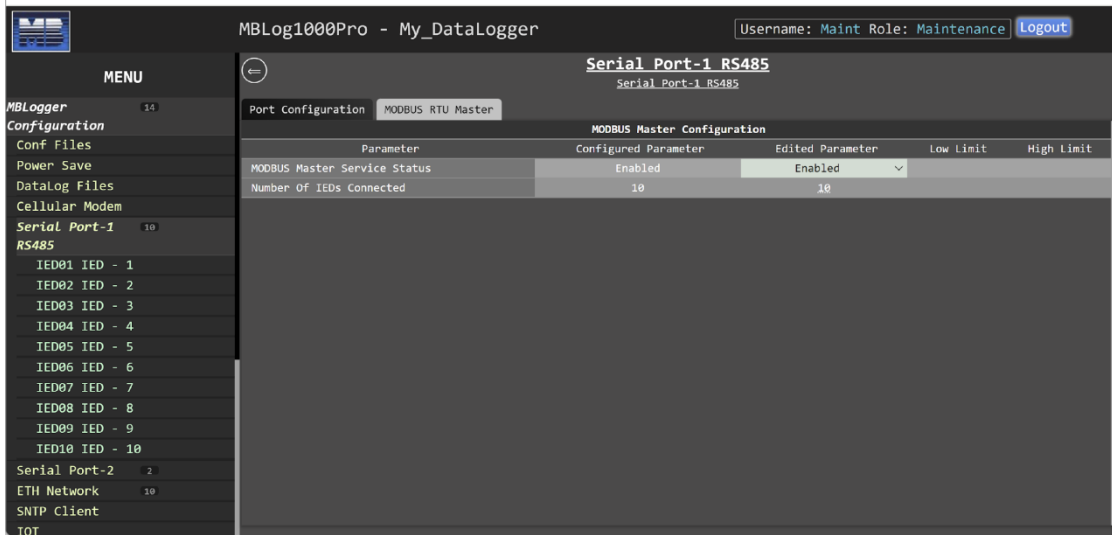

Figure-6.9: Configuration of serial port-1 RS485.

Configuration details of communication parameters for serial port-1 RS485 are provided in table 6.9 below.

Sr. No	Parameter	Description	Remarks
1	Port Service	Select service for the port: MODBUS master or MODBUS slave	Tab will be displayed as per the service selected on the port. MODBUS RTU Master or MODBUS RTU Slave. Configure the service parameters by selecting the service tab

Table-6.9: Configuration – serial port-1 RS485

Up-to ten IED/ sensors can be configured for communication on this port.

## 6.10 Configure – Serial Port-2

Serial port-2 can be configured for use as RS485 or RS232. Separate hardware ports have been provided for this. Any one hardware port shall be operational based on the port configuration.

Left click on menu option ‘Serial Port-2’ to configure this port as shown in figure-6.10 below.



Figure-6.10: Configuration of serial port-2.

Configuration details of communication parameters for serial port-2 are provided in table 6.10 below.

Sr. No	Parameter	Description	Remarks
1	Port Type	Select port type RS485 or RS232	Any one of the options can be used. Configure the port RS485 or RS232 parameters based on this selection

Table-6.10: Configuration – serial port-2

### 6.10.1 Configure – Serial Port-2 (RS485)

Configure serial port -2 RS485 parameter if the port has been configured for RS485 operation.

This port can be used as MODBUS RTU Master or MODBUS RTU Slave.

MODBUS slave devices can be connected to this port. See here configuration details for MODBUS slave devices.

Left click on menu option ‘Serial Port-2 RS485’ to configure this port as shown in figure-6.10.1 below.

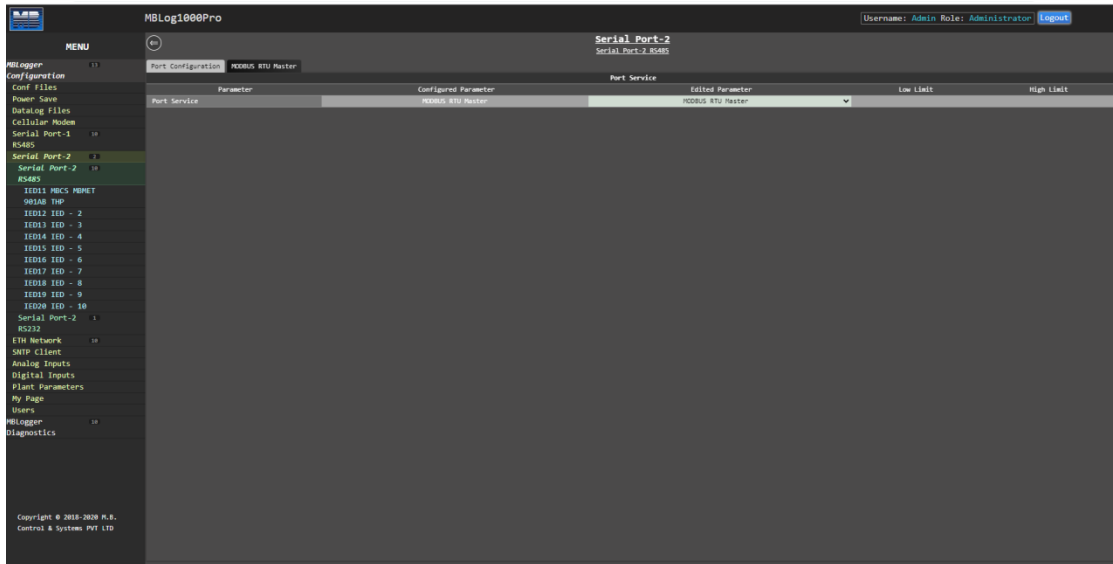

Figure-6.10.1: Configuration of serial port-2 RS485.

Configuration details for serial port-2 RS485 are provided in table 6.10.1 below.

Sr. No	Parameter	Description	Remarks
1	Port Service	Select service for the port: MODBUS master or MODBUS slave	Tab will be displayed as per the service selected on the port. MODBUS RTU Master or MODBUS RTU Slave. Configure the service parameters by selecting the service tab

Table-6.10.1: Configuration – serial port-2 RS485

Up-to ten IED/ sensors can be configured for communication on this port

### 6.10.2 Configure – Serial Port-2 (RS232)

Configure serial port -2 RS232 parameters if the port has been configured for RS232 operation.

This port can be used to read parameters from devices having ASCII protocol.

Only one device can be connected to this port. See here configuration details for ASCII devices.

Left click on menu option ‘Serial Port-2 RS232’ to configure this port as shown in figure-6.10.2 below.

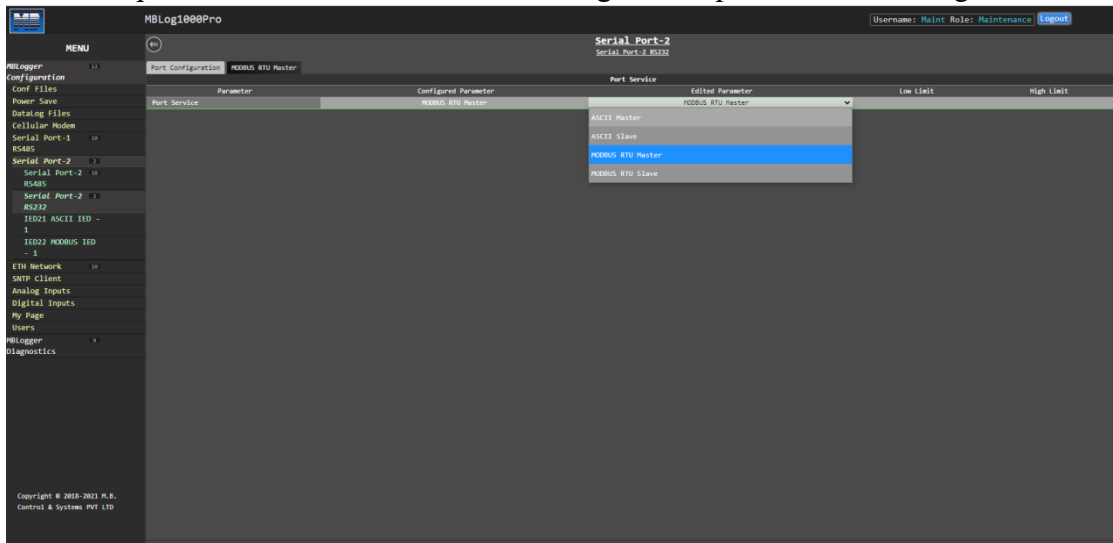

Figure-6.10.2: Configuration of serial port-2 RS232.

Configuration details for serial port-2 RS232 are provided in table 6.10.2 below.

Sr. No	Parameter	Description	Remarks
1	Port Service	Select service for the port: MODBUS RTU Master, MODBUS RTU Slave, ASCII master or ASCII slave	This port is used to communicate with devices having ASCII or MODBUS RTU communication protocols. Select as per the device connected to the port.

Table-6.10.2: Configuration – serial port-2 RS232

Only one IED/ sensors can be configured for communication with this port.

### 6.10.3 Configure – Serial Port-2 (RS232) – MODBUS RTU Master

Select ‘MODBUS RTU Master’ to interface serial MODBUS RTU device to the port.

Select tab ‘MODBUS RTU Master’ to configure the protocol parameters as shown in figure-6.10.3 below.

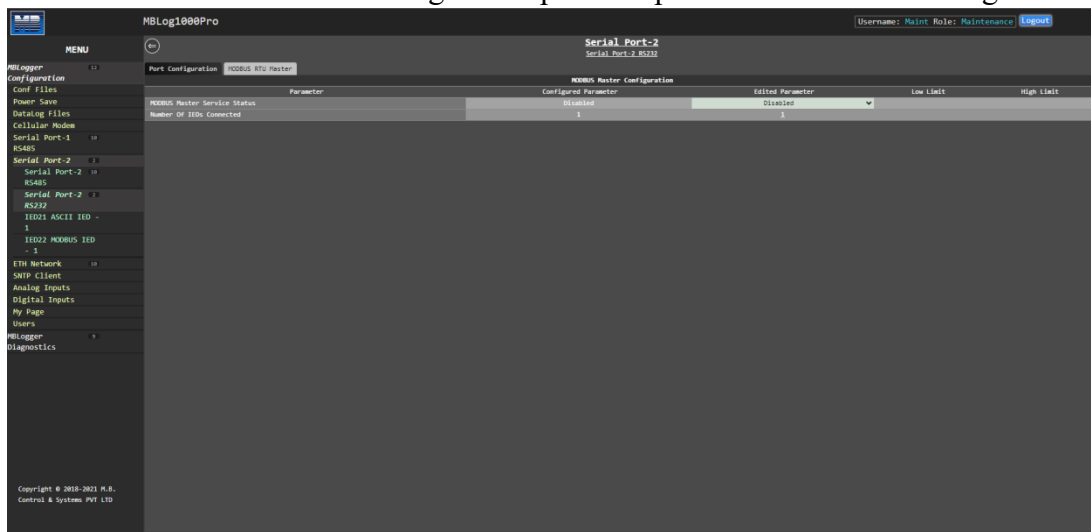

Table-6.10.3: Configuration – serial port-2 RS232 – MODBUS Master parameters

Only one MODBUS IED with RS232 port can be interfaced with this port.

## 6.10.4 Configure – Serial Port-2 (RS232) – MODBUS RTU Slave

Select ‘MODBUS RTU Slave’ to operate the port as MODBUS RTU Slave.

Select tab ‘MODBUS RTU Slave’ to configure the protocol parameters as shown in figure-6.10.4 below.

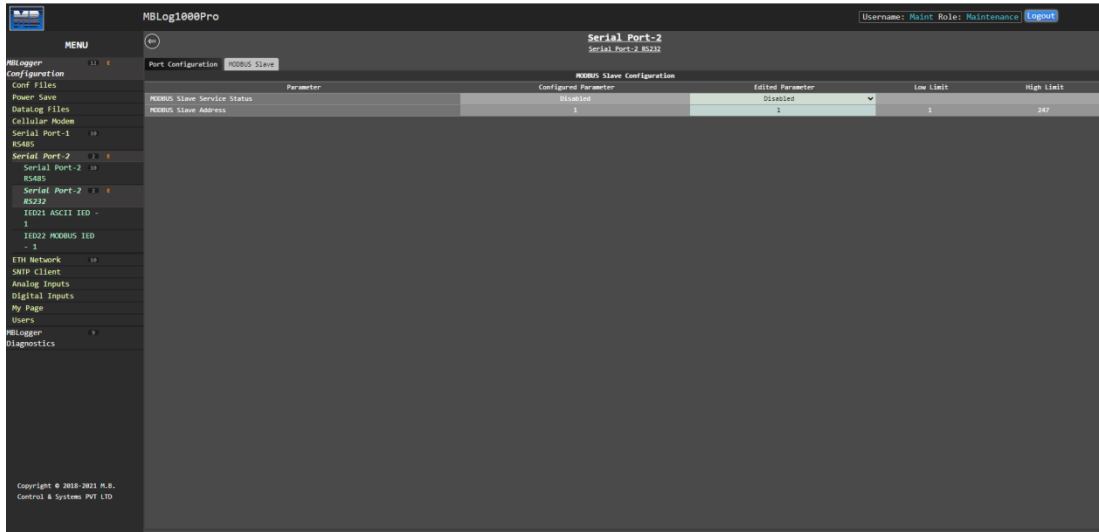

Table-6.10.4: Configuration – serial port-2 RS232 – MODBUS Slave parameters

## 6.10.5 Configure – Serial Port-2 (RS232) – ASCII Master/ Slave

Select ‘ASCII Master’ or ‘ASCII Slave’ to operate the port as ASCII Master or Slave.

Select tab ‘MODBUS RTU Slave’ to configure the protocol parameters as shown in figure-6.10.5 below.

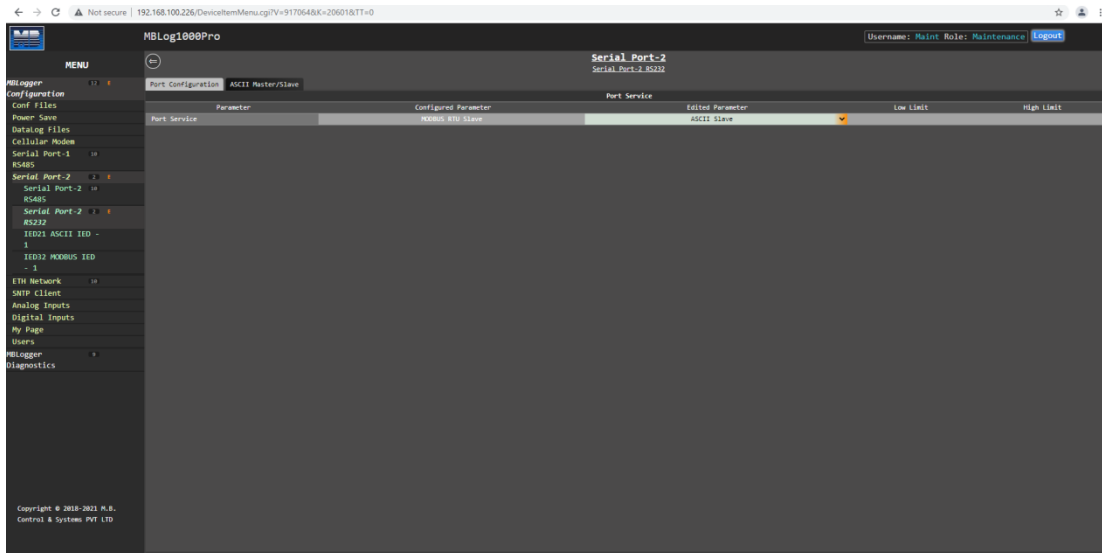

Table-6.10.5: Configuration – serial port-2 RS232 – ASCII Master/ Slave parameters

## 6.11 Configure – ETH Network

Left click on menu option ‘ETH Network’ to configure datalogger ETH network and its services as shown in figure-6.11 below.

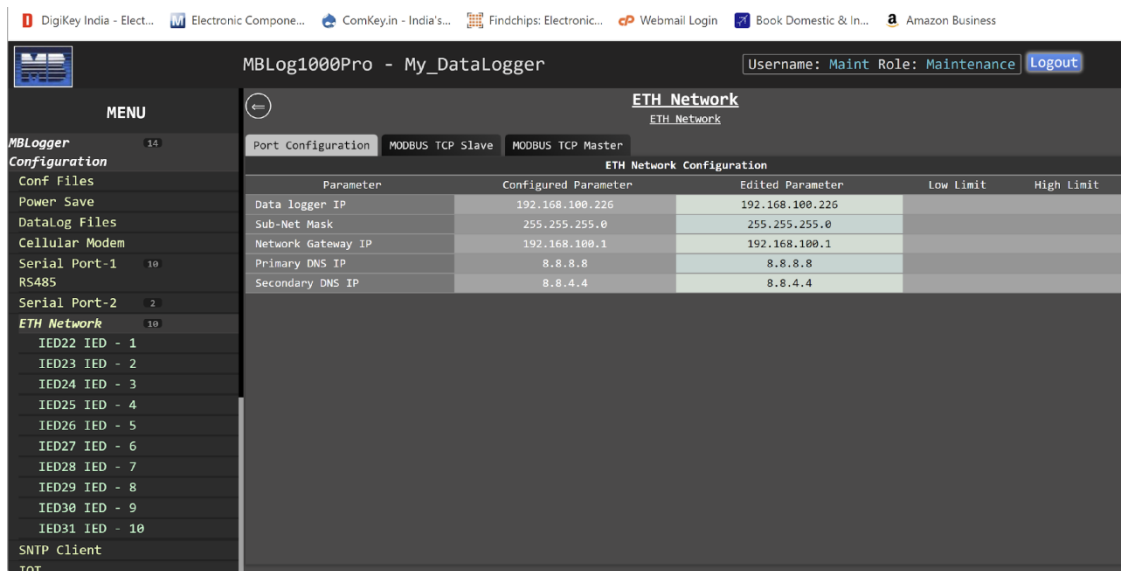

Figure-6.11: Configuration of datalogger ETH network.

Configuration details for ETH port are provided in table 6.11.1 below.

Sr. No	Parameter	Description	Remarks
1	Data Logger IP	Data logger IP	
2	Data Logger Subnet mask	Data Logger Subnet mask	
3	Network Gateway IP	Network Gateway IP	This IP shall be used for internet access via ETH port
4	Primary DNS IP		Set primary DNS
5	Secondary DNS IP		Set secondary DNS

Table-6.11.1: Configuration – ETH Port parameters

Details for tabs for configuration of services on ETH port are provided in table 6.11.2 below.

Sr. No	Tab	Description	Remarks
1	MODBUS TCP Slave	Configure MODBUS TCP slave service	
2	MODBUS TCP Master	Configure MODBUS TCP Master service	

Table-6.11.2: Configuration – ETH port services

Up-to ten IED/ sensors can be configured for communication on this port.

## 6.12 Configure – Sensors and IED on MODBUS Master Ports

Various sensors and IED can be interfaced to ports having MODBUS RTU Master (serial – RS485 and RS232) or MODBUS TCP Master (ETH) services.

Extensive library (for sensors, inverters and MFM) has been provided in the MBLogger to make their selection and configuration quite easy. This configuration can be completed in few steps.

Left click on menu option for the port to which the sensor or IED is to be added.

Menu option will display five IED's already added to the port.  
 Select the IED to configure by left click on the menu option.  
 Configure the selected IED by selecting the configuration tabs.

### 6.12.1 IED Communication

IED communication parameters can be configured by selecting the tab – 'IED Communication'.

IED communication parameters are shown in figure-6.12.1 below.

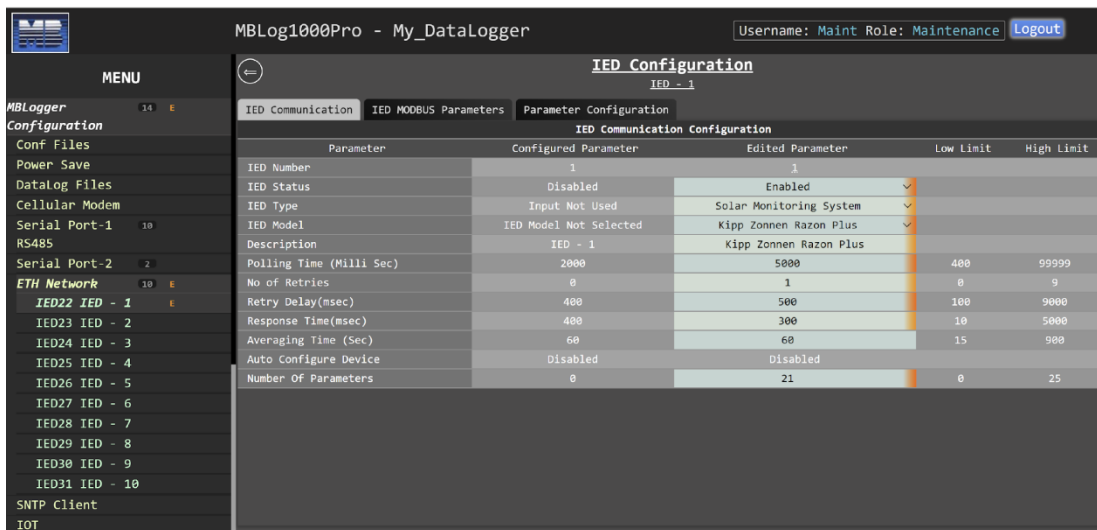

Figure-6.12.1: Configuration of IED communication parameters.

Configuration details IED communication parameters are provided in table 6.12.1 below.

Sr. No	Parameter	Description	Remarks
1	IED Status		Enabled or Disabled. Disabled IED's will not be polled.
2	IED Type	Select IED type from the drop-down list of libraries of sensors and IED's provided.	The IED shall be disabled if 'Input Not Used' is selected. Select 'Other IED' none of the library selection is required.
3	IED Model	Select IED model number from drop-down list provided.	List of IED model numbers shall be provided based on the 'IED Type' selected above. For configuring custom IED, use option 'Other IED'.
4	Description		IED description. This description will be used for data logging and IOT communication.
5	Polling Time (Milli Second)		Set IED polling time in milli seconds.
6	No of Retries		IED communication retries
7	Retry Delay (msec)		Polling retry delay in milli seconds.
8	Response time (Sec)		Expected response time from the IED.

9	Averaging Time (sec)	Parameter value averaging time	Statistical calculations will be based on this time for the IED parameters. 'Minimum value', 'Maximum value', 'Average value' and 'Standard Deviation'.
10	Auto Configure Device	Some MBCS IED can be configured as required via the data logger.	'Enable' for auto configuring the MBCS IED as per configuration set on the data logger.
11	Number of Parameters	Number of parameters for the IED/ Sensor	Maximum twenty-five parameters can be configured for each IED.

Table-6.12.1: Configuration – IED communication parameters

Note:

IED communication status is provided in MODBUS Slave registers – 10455 to 10459 (refer section 10.9).

### 6.12.2 IED MODBUS Parameters

IED MODBUS communication parameters can be configured by selecting the tab – 'IED MODBUS Parameters'.

IED MODBUS parameters are shown in figure-6.12.2 below.

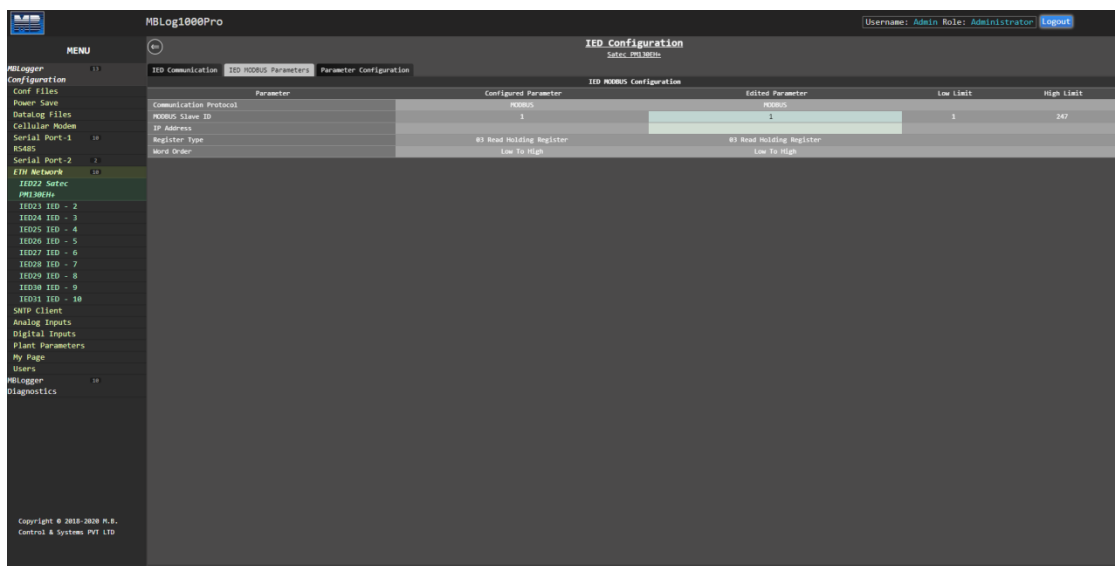

Figure-6.12.2: Configuration of IED MODBUS communication parameters.

Configuration details IED MODBUS parameters are provided in table 6.10.2 below.

Sr. No	Parameter	Description	Remarks
1	IP Address	Provide IED IP address	IP address needs to be configured only if the IED is interface to datalogger ETH port.

Table-6.12.2: Configuration – IED MODBUS parameters

MODBUS slave address for each IED/ sensor connected to the port should be unique.

### 6.12.3 IED Parameter Configuration

Parameters to be read from IED can be configured by selecting the tab – ‘Parameter Configuration’.

List of parameters to be read from the IED will be displayed.

For IED’s selected from the library, pre-configured parameters will be listed on this page.

Configuration details for IED parameters are shown in figure-6.12.3 below.

Parameter No.	Description	Type	Reg Addr	Reg Length	Roll Over Value	Std Dev Calc.	Integration Resolution	Datalog	IOT	MODBUS Register	
1	Date Averaging In	Analog	100	Unsigned 32 bits		Disable	Disabled	1.0	Disabl	Disabl	6800
2	Time Averaging In	Analog	102	Unsigned 32 bits		Disable	Disabled	1.0	Disabl	Disabl	6812
3	Local Date Averag	Analog	104	Unsigned 32 bits		Disable	Disabled	1.0	Disabl	Disabl	6824
4	Local Time Averag	Analog	106	Unsigned 32 bits		Disable	Disabled	1.0	Disabl	Disabl	6836
5	Solar Azimuth	Analog	108	Float 32 bits		Disable	Disabled	1.0	Disabl	Disabl	6848
6	Solar Zenith	Analog	110	Float 32 bits		Disable	Disabled	1.0	Disabl	Disabl	6860
7	Latitude	Analog	112	Float 32 bits		Disable	Disabled	1.0	Disabl	Disabl	6872
8	Longitude	Analog	114	Float 32 bits		Disable	Disabled	1.0	Disabl	Disabl	6884
9	Air Pressure	Analog	116	Float 32 bits		Disable	Disabled	1.0	Enabl	Disabl	6896

Figure-6.12.3: Configuration of IED read parameters.

Up-to twenty-five parameters can be configured for each IED for MODBUS communication.

Configuration details IED parameters are provided in table 6.12.3.1 below.

Sr. No	Parameter	Description	Remarks
1	Description	Parameter description	
2	Type	Parameter Type	Following options are provided: Totalised Analog Solar Irradiation Power Factor Wind Direction Wind Speed
3	Reg Address	MODBUS Register address	
4	Register Length	Parameters register length	Following options are provided: Unsigned 16 bits Signed 16 bits. Unsigned 32 bits Signed 32 bits. Float 32 bits
5	Roll Over Value	Roll value for the parameter	For accumulating parameters
6	Standard Deviation Calculation	Enable or Disable calculation of standard deviation for the parameter.	If enabled, this parameter attribute will be available for display and on datalogger MODBUS slave

7	Integration	Enable or Disable integration of the parameter.	Integration can be used to calculate totalised parameter from instantaneous parameter value. e.g. calculate solar radiation energy from solar irradiance
8	Resolution	Parameter read resolution	This is used to get actual parameter float value.
9	Data log	Enable or Disable logging of the parameter.	If enabled parameter will be logged the log files. Parameter will be logged with all its attributes – ‘Min Value’, ‘Average Value’, ‘Max Value’, ‘Instantaneous Value’, ‘SD Value’ and ‘Integrated Value’
10	IOT	Select for communication of parameter value via IOT	<b>‘Disable’</b> : IOT transmission is disabled. <b>‘Value’</b> : Only parameter value is transmitted. <b>‘Value and Stat’</b> : Parameter value and its statistics are also transmitted.
11	MODBUS Slave Register	MODBUS register address for the parameter for datalogger MODBUS slave service	External devices or SCADA can read value of the parameter and its attributes from this MODBUS slave register address.

Table-6.12.3.1: Configuration – IED read parameters.

All the parameters are pre-configured for IED/ sensor selected from library.

MODBUS Slave register (signed 32 bits) details for IED parameters are provided in table 6.10.3.2 below.

Sr. No	Datalogger MODBUS Slave Register	Parameter
1	MODBUS Slave Starting Register Address	Parameter Value
2	+2	Parameter minimum Value
3	+4	Parameter maximum Value
4	+6	Parameter average value
5	+8	Parameter standard deviation. This value will be available if it is enabled in configuration. Else this will be ‘0’.
6	+10	Parameter integrated value. This value will be available if it is enabled in configuration. Else this will be ‘0’.

Table-6.12.3.2: IED parameters – MODBUS Slave registers

Communication status of all IED’s are provided via MODBUS Slave registers. Refer to sec. for details.

## 6.13 Configure – Sensors and ASCII IED on Serial RS232 Port

Various sensors and IED can be interfaced to serial RS232 port having ASCII Master or ASCII slave protocol.

Extensive library (for devices having ASCII protocol) has been provided in the MBLLogger to make their selection and configuration quite easy.

Left click on menu option for the serial RS232 port.

Menu option will display one IED already added to the port. Only one IED/ sensor can be added to the RS232 port.

Select this IED to configure by left click on the menu option.

Configure the selected IED by selecting the configuration tabs provided.

### 6.13.1 IED Communication

ASCII IED communication parameters can be configured by selecting the tab – ‘IED Communication’. IED communication parameters are shown in figure-6.13.1 below.

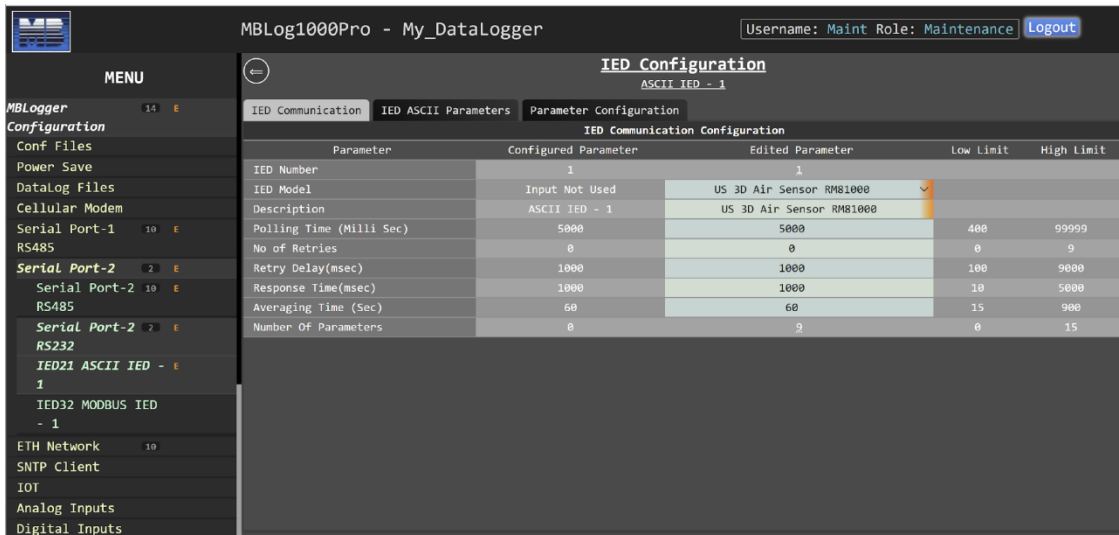

Figure-6.13.1: Configuration of ASCII IED communication parameters.

Configuration details ASCII IED communication parameters are provided in table 6.13.1 below.

Sr. No	Parameter	Description	Remarks
1	IED Model	Select IED model number from drop-down list provided.	List of IED models shall be provided based on the ‘IED Type’ selected above. For configuring custom IED, use option ‘Other Make Sensor’.
2	Description		IED description. This description will be used for data logging and IOT communication.
3	Polling Time (Milli Second)		Set IED polling time in milli seconds.
4	No of Retries		IED communication retries
5	Retry Delay (msec)		Polling retry delay in milli seconds.

6	Response time (Sec)		Expected response time from the IED.
7	Averaging Time (sec)	Parameter value averaging time	Statistical calculations will be based on this time for the IED parameters. 'Minimum value', 'Maximum value', 'Average value' and 'Standard Deviation'.
8	Number of Parameters	Number of parameters for the IED/ Sensor	Maximum twenty-five parameters can be configured for each IED.

Table-6.13.1: Configuration – IED ASCII communication parameters

### 6.13.2 IED ASCII Parameters

IED ASCII communication parameters can be configured by selecting the tab – ‘IED ASCII Parameters’. IED ASCII communication parameters are shown in figure-6.13.2 below.

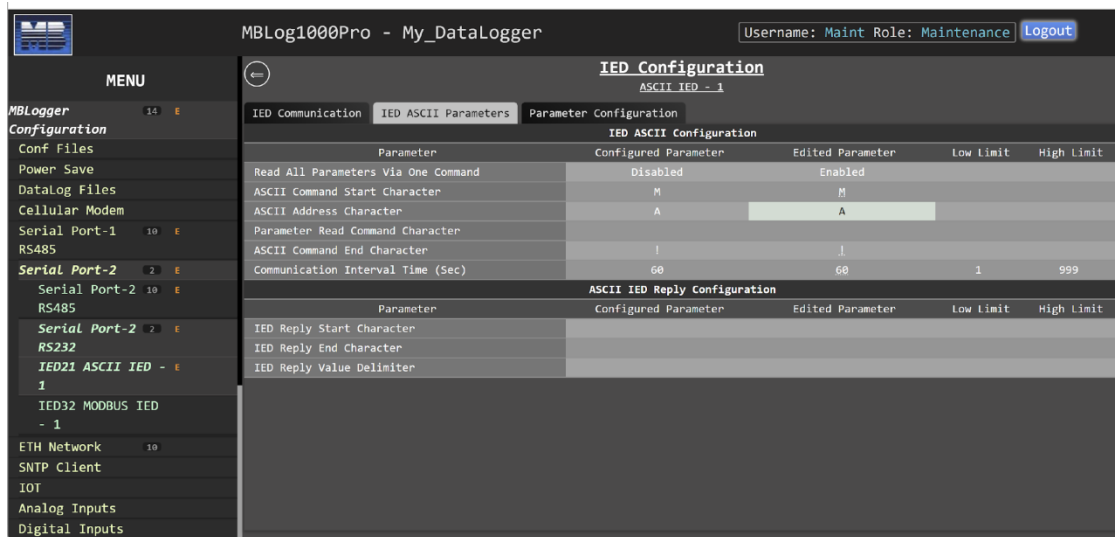

Figure-6.13.2: Configuration of IED ASCII communication parameters.

Configuration details IED ASCII communication parameters are provided in table 6.13.2 below.

Sr. No	Parameter	Description	Remarks
<b>ASCII Command String Parameters</b>			
1	Read All Parameters in one command	Enable / Disable reading of all IED parameters in one ASCII command	Enable if all ASCII IED parameters can be read in one command
2	ASCII Command Start Character	Command start ASCII character	Will indicate start of the ASCII command string.
3	ASCII Address Character	ASCII character address	Address of the ASCII IED

4	Parameter read command Character	ASCII command to enable reading of all parameters in one command.	May be configured as “null” also. Will be used only if reading of all parameters by one command is enabled.
5	ASCII Command End Character	Command end ASCII character	Will indicate end of the ASCII command string. All ASCII command strings will be terminated by “CR” and “LF”.
6	Communication Interval Time (Sec)	This parameter is set if the port is using ASCII slave protocol.	This is the time interval in seconds at which ASCII IED send parameters to the datalogger. If no message is received from the IED during this time – communication fail with the IED will be notified.
<b>ASCII Reply String Configuration</b>			
1	Reply Start ASCII Character	ASCII character to indicate start of reply character string	May be configured as “Null”.
2	IED Reply End Character	ASCII character to indicate end of reply character string	May be configured as “Null”.
3	Reply Value Delimiter	ASCII character to delimit parameter values.	May be configured as “Null”. If it is configured as ‘Null’, parameters will be assumed to have fixed length as explained in parameter configuration below.

Table-6.13.2: Configuration – IED ASCII communication parameters

### 6.13.3 ASCII IED Parameter Configuration

Parameters to be read from ASCII IED can be configured by selecting the tab – ‘Parameter Configuration’. List of parameters to be read from the IED will be displayed.

For IED’s selected from the library, pre-configured parameters will be listed on this page.

Configuration details for ASCII IED parameters are shown in figure-6.13.3 below.

MBLog1000Pro - My_DataLogger										
IED Configuration										
ASCII IED - 1										
Parameter Configuration										
Configuration										MODBUS Slave Register
Parameter No.	Description	Type	ASCII Address	Parameter Length	Std Dev Calc.	Integration	Resolution	DataLog	IOT	MODBUS Register
1	Wind Speed U	Wind Speed		5	Disable	Disabled	0.01	Disable	Value	6500
2	Wind Speed V	Wind Speed		5	Disable	Disabled	0.01	Disable	Value	6512
3	Wind Speed W	Wind Speed		5	Disable	Disabled	0.01	Disable	Value	6524
4	Wind Speed 2D	Wind Speed		5	Disable	Disabled	0.01	Disable	Value	6536
5	Wind Speed 3D	Wind Speed		5	Disable	Disabled	0.01	Disable	Value	6548
6	Azimuth	Analog		5	Disable	Disabled	0.01	Disable	Value	6560
7	Elevation	Analog		5	Disable	Disabled	0.01	Disable	Value	6572
8	Speed of Sound	Analog		5	Disable	Disabled	0.01	Disable	Value	6584
9	Sonic Temp	Analog		5	Disable	Disabled	0.01	Disable	Value	6596

Figure-6.13.3: Configuration of ASCII IED read parameters.

Configuration details ASCII IED parameters are provided in table 6.11.3.1 below.

Sr. No	Parameter	Description	Remarks
1	ASCII Address	ASCII character for Parameter address.	Can be configured as “Null”. This address is not required if all the IED parameters are configured to be read by one command. Refer to sec. 6.11.2 above.
2	Parameter Length	Number of characters used for value of the parameter in the ASCII reply frame.	Will be used if parameter delimiter is not defined in sec. 6.11.2 above.
3	Data log	Enable or Disable logging of the parameter.	If enabled parameter will be logged the log files. Parameter will be logged with all its attributes – ‘Min Value’, ‘Average Vale’, ‘Max Value’, ‘Instantaneous Value’, ‘SD Value’ and ‘Integrated Value’
4	IOT	Select for communication of parameter value via IOT	‘Disable’: IOT transmission is disabled. ‘Value’: Only parameter value is transmitted. ‘Value and Stat’: Parameter value and its statistics are also transmitted.
4	MODBUS Slave Register	MODBUS register address for the parameter for datalogger MODBUS slave service	External devices or SCADA can read value of the parameter and its attributed from this MODBUS slave register address.

Table-6.13.3.1: Configuration – ASCII IED read parameters.

MODBUS Slave register (signed 32 bits) details for IED parameters are provided in table 6.13.3.2 below.

Sr. No	Datalogger MODBUS Slave Register	Parameter
1	MODBUS Slave Starting Register Address	Parameter Value
2	+2	Parameter minimum Value
3	+4	Parameter maximum Value
4	+6	Parameter average value
5	+8	Parameter standard deviation. This value will be available if it is enabled in configuration. Else this will be ‘0’.
6	+10	Parameter integrated value. This value will be available if it is enabled in configuration. Else this will be ‘0’.

Table-6.13.3.2: IED parameters – MODBUS Slave registers

## 6.14 Configure – SNTP Client

SNTP client can be used to synchronize internal clock of the datalogger. SNTP service can be used via ETH network or device internal modem.

Time synchronization can also be done via GPS or Modem.

Up to four NTP time servers can be configured. SNTP client will switch over to next time server if any server fails to respond.

Left click on menu option ‘SNTP Client’ for configuration as shown in figure-6.14 below.

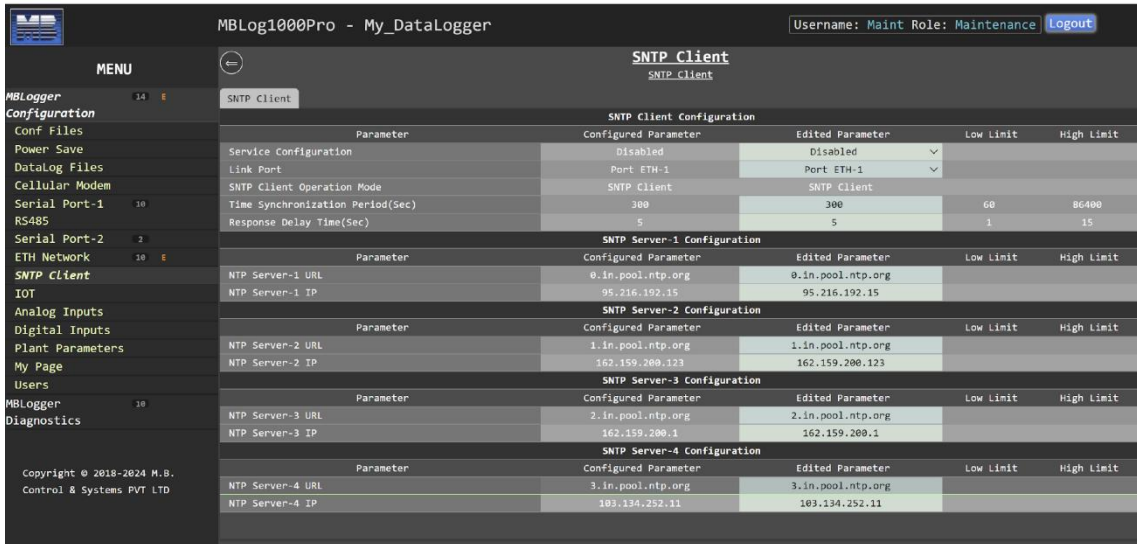

Figure-6.14: Configuration of SNTP client.

SNTP client will operate in ‘Client Mode’ only.

Configuration details of SNTP clients are provided in table 6.14 below.

Sr. No	Parameter	Description	Remarks
1	Service Configuration		Enabled or Disabled.
2	Link Port	Select communication port	ETH or Modem can be used.
3	Time synchronisation period (Sec)		Time period in seconds for time synchronisation. <i>Too short time period will use more communication resource.</i>
<b>SNTP Server Configuration</b>			
1	NTP Server URL or IP	Configure NTP server IP or URL. Either of the two can be configured.	SNTP client will get time from any of the configured and working NTP servers. URL will be resolved if DNS are configured.

Table-6.14: Configuration – SNTP Client

*To use modem for SNTP – ensure that it is enabled, and SIM is installed.*

## 6.15 Configure – IOT (MQTT)

IOT (MQTT) communication parameters can be configured via this page.

*IOT communication can be used for transmitting real time parameter values to MBCS or other compatible cloud services.*

This service is also used for remote diagnostic and monitoring of the data logger status. This helps in remote diagnostic and reducing downtime of the datalogger.

IOT communication can be done ETH port or device modem. If ETH port is used, proper internet service and gateway configuration is required.

Left click on menu option ‘IOT’ for configuration as shown in figure-6.15 below.

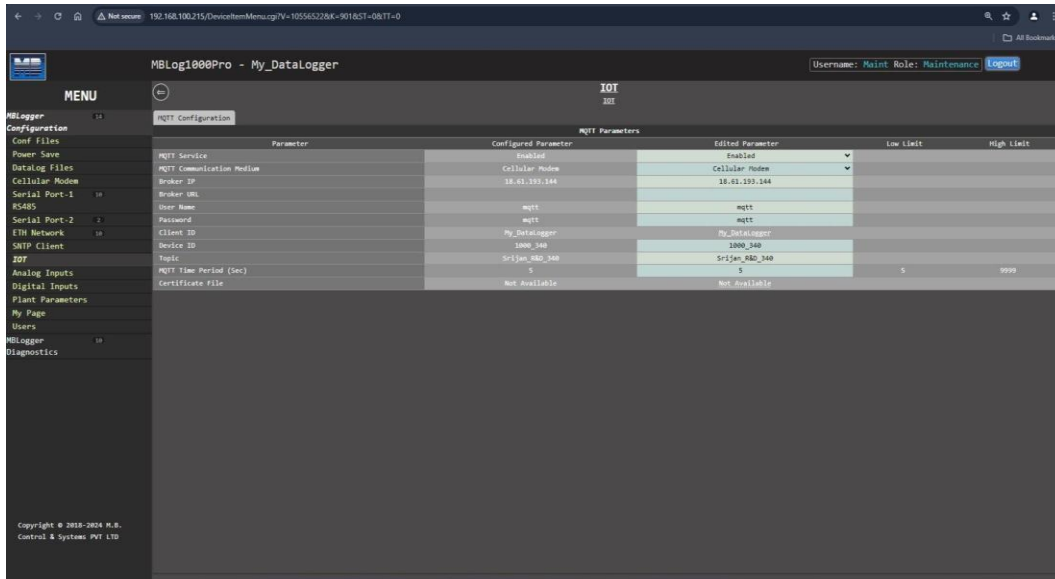

Figure-6.15: Configuration of IOT services.

Configuration details of IOT parameters are provided in table 6.15 below.

Sr. No	Parameter	Description	Remarks
1	MQTT service		Enabled or Disabled.
2	MQTT Communication Media	Select communication port	ETH or Modem can be used.
3	Broker IP		Set MQTT Broker IP
4	Broker URL		Set MQTT Broker URL – if broker IP is not known.
5	User Name		Username and password for communication with broker
6	Password		
7	Client ID		This is datalogger name
8	Device ID		Unique device ID to be provided by MBCS cloud team.
9	Topic		Configurable, usually site name.
10	MQTT Time Period (Sec)		Time period in seconds for data communication. <i>This time should set as per actual application requirements. Too fast</i>

			<i>communication may choke communication channel bandwidth.</i>
11	TLS Certificate File		TLS certificate file

Table-6.15: Configuration – IOT

Following remote diagnostic functionality is provided:

- i) Device status log
- ii) Device value log
- iii) ADC operation logs
- iv) MODBUS Communications logs
- v) Modem operation log
- vi) Remote device reset.

## 6.16 Configure – Analog Input Channels

MLogger provides various types of analog input channels. Details of these input channels is provided in table 6.16 below.

Sr. No	Input Type	Number of Channels	Resolution
1	Input mA (4-20mA)	4	24 bits
2	Input mV (0-1000mV)	4	24 bits
3	Input V (0-10V)	4	24 bits
4	Battery Voltage (0-32V) or RTD (PT100 or PT1000)	1	24 bits

Table-6.16: Analog input channels

An extensive library of sensors has been provided in the datalogger for selection and configuration.

Left click on menu option ‘Analog Inputs’ to configure analog input channels as shown in figure-6.16 below.

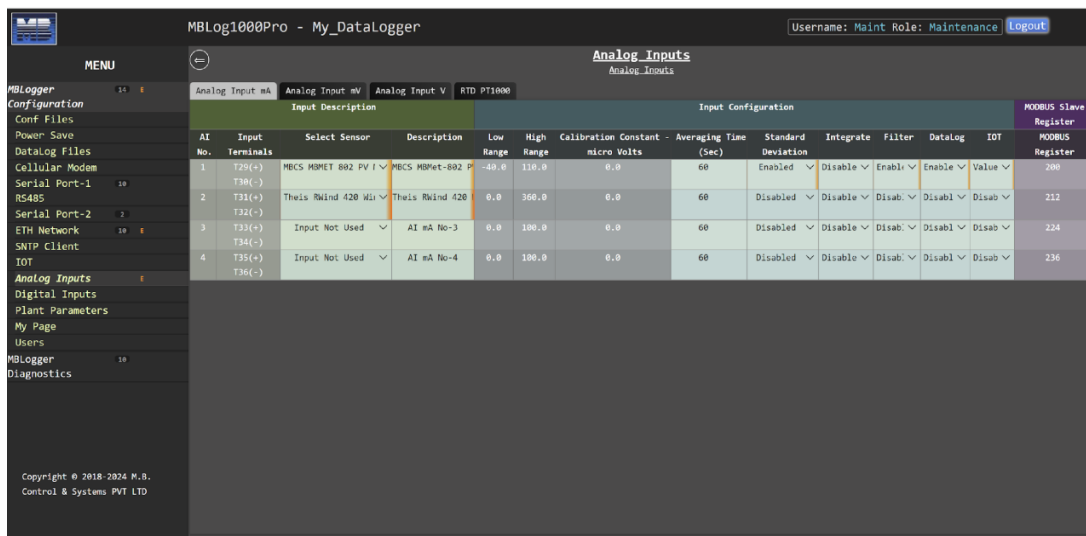

Figure-6.16: Configuration of analog input channels.

Each type of analog input channel can be configured by using its tab.

## 6.16.1 Configure – Analog Input mA

Select tab ‘Analog Input mA’ to configure mA input (4-20mA) channels as shown in figure-6.16.1 below.

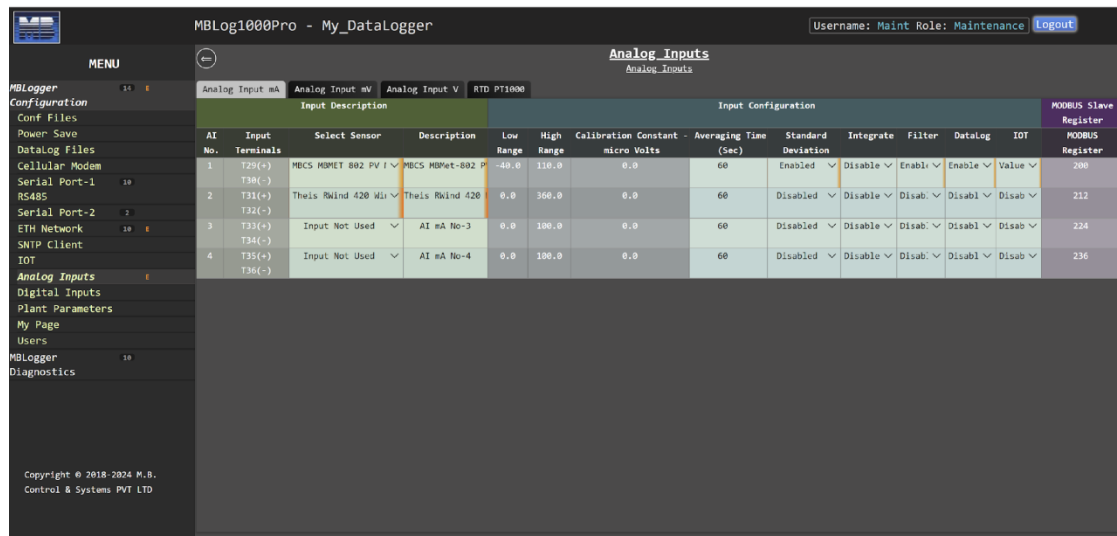

Figure-6.16.1: Configuration of mA input channels.

Configuration details for mA input channels are provided in table 6.16.1.1 below.

Sr. No	Parameter	Description	Remarks
1	Input Terminals	Data logger terminal numbers for the input channel.	
2	Select Sensor	Select required sensor to be connected input. Select ‘None’ if the channel is not used. Select ‘Other’ to configure your own input signal.	All parameters for the channel will be configured as per the selected sensor and will not be editable.
3	Averaging Time (sec)	Averaging time for the input signal	All statistical for the signal computations will be based on this time.
4	Integration	Enable or Disable integration of the parameter.	Integration can be used to calculated totalised parameter from instantaneous parameter value. e.g. calculate solar radiation energy from solar irradiance
5	Filter	Enable or Disable Filter	If enabled five sample average is calculated
6	Data log	Enable or Disable logging of the parameter.	If enabled parameter will be logged the log files. Parameter will be logged with all its attributes – ‘Min Value’, ‘Average Vale’, ‘Max Value’,

			‘Instantaneous Value’, ‘SD Value’ and ‘Integrated Value’
7	IOT	Enable transmission of parameter value via IOT.	<p><b>‘Disable’</b>: IOT transmission is disabled.</p> <p><b>‘Value’</b>: Only parameter value is transmitted.</p> <p><b>‘Value and Stat’</b>: Parameter value and its statistics are also transmitted.</p>
8	MODBUS Slave Register	MODBUS register address for the parameter for datalogger MODBUS slave service	External devices or SCADA can read value of the parameter and its attributed from this MODBUS slave register address.

Table-6.16.1.1: Configuration – mA input channels

MODBUS Slave register (32 bits float) details for mA input channels is provided in table 6.16.1.2 below.

Sr. No	Datalogger MODBUS Slave Register	Parameter
1	MODBUS Slave Starting Register Address	Parameter Value
2	+2	Parameter minimum Value
3	+4	Parameter maximum Value
4	+6	Parameter average value
5	+8	Parameter standard deviation. This value will be available if it is enabled in configuration. Else this will be ‘0’.
6	+10	Parameter integrated value. This value will be available if it is enabled in configuration. Else this will be ‘0’.

Table-6.16.1.2: Analog input mA – MODBUS slave register details

Note:

Quality of mA measurements is provided in MODBUS Slave register – 10450 (refer section 10.9).

### 6.16.2 Configure – Analog Input mV

Select tab ‘Analog Input mV’ to configure mV input (0-1,000mV) channels as shown in figure-6.16.2 below.

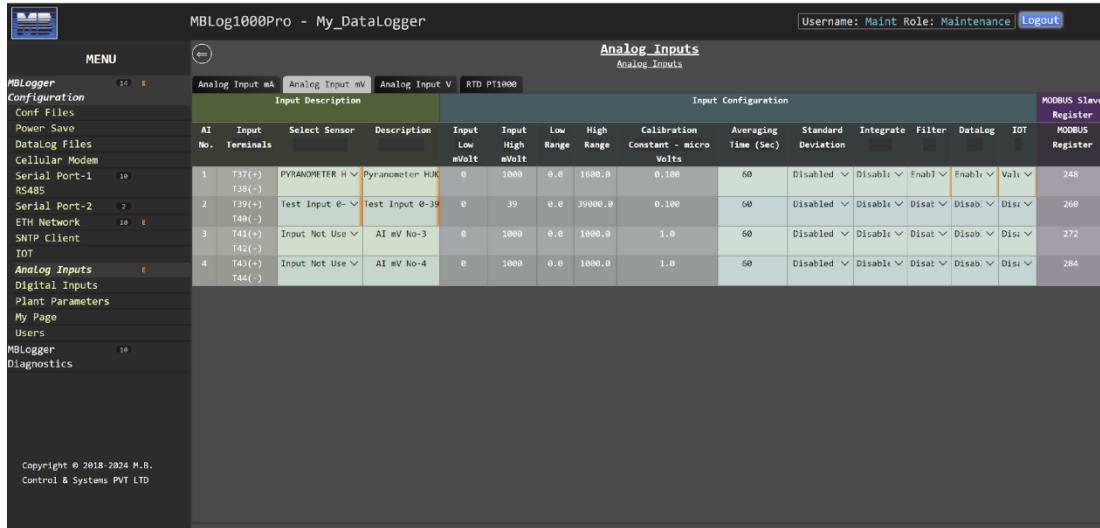

Figure-6.16.2: Configuration of mV input channels.

Configuration details for mV input channels are provided in table 6.16.2.1 below.

Sr. No	Parameter	Description	Remarks
1	Select Sensor	Select required sensor to be connected input. List of sensors that can be interfaced on the channel shall be provided	All parameters for the channel will be configured as per the selected sensor and will not be editable.
2	Calibration Constant	Enter calibration constant for the pyranometer.	This field will be enabled if calibration constant is required for the selected pyranometer sensor. Calculated value = mv input *1000/ calibration constant
3	Filter	Enable or Disable Filter	If enabled five sample average is calculated
4	Data log	Enable or Disable logging of the parameter.	If enabled parameter will be logged the log files. Parameter will be logged with all its attributes – ‘Min Value’, ‘Average Vale’, ‘Max Value’, ‘Instantaneous Value’, ‘SD Value’ and ‘Integrated Value’
5	IOT	Enable transmission of parameter value via IOT.	‘Disable’: IOT transmission is disabled. ‘Value’: Only parameter value is transmitted. ‘Value and Stat’: Parameter value and its statistics are also transmitted.

Table-6.16.2.1: Configuration – mV input channels

MODBUS Slave register (32 bits float) details for mV input channels is provided in table 6.16.2.2 below.

Sr. No	Datalogger MODBUS Slave Register	Parameter
1	MODBUS Slave Starting Register Address	Parameter Value
2	+2	Parameter minimum Value
3	+4	Parameter maximum Value

4	+6	Parameter average value
5	+8	Parameter standard deviation. This value will be available if it is enabled in configuration. Else this will be '0'.
6	+10	Parameter integrated value. This value will be available if it is enabled in configuration. Else this will be '0'.

Table-6.16.2.2: Analog input mV – MODBUS slave register details

Note:

Quality of mV measurements is provided in MODBUS Slave register – 10451 (refer section 10.9).

### 6.16.3 Configure – Analog Input V

Select tab 'Analog Input V' to configure Voltage input (0-10V) channels as shown in figure-6.16.3 below.

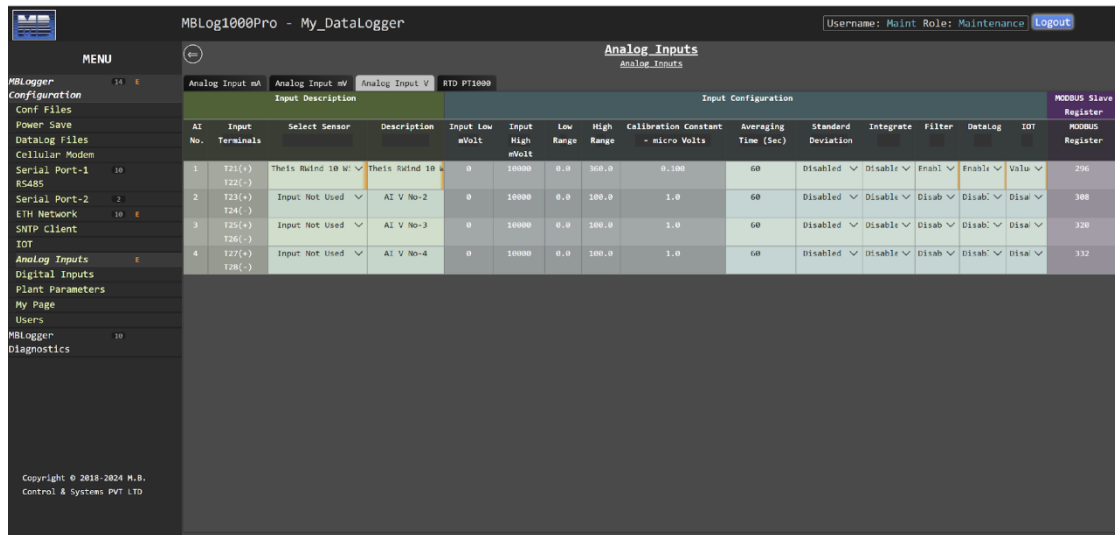

Figure-6.16.3: Configuration of Voltage input channels.

Configuration details for Voltage input channels are provided in table 6.16.3.1 below.

Sr. No	Parameter	Description	Remarks
1	Select Sensor	Select required sensor to be connected input. List of sensors that can be interfaced on the channel shall be provided	All parameters for the channel will be configured as per the selected sensor and will not be editable.
2	Input Low Voltage	Input low voltage for the sensor	This field will be non-editable if any sensor is selected from library.
3	Input High Voltage	Input high voltage for the sensor	This field will be non-editable if any sensor is selected from library. This field will be editable for Barani Design wind direction sensor. Enter actual high voltage for the sensor.

4	Calibration Constant	Enter calibration constant for the pyranometer.	This field will be enabled if calibration constant is required for the selected pyranometer sensor. Calculated value = mv input *1000/ calibration constant
5	Filter	Enable or Disable Filter	If enabled five sample average is calculated
6	Data log	Enable or Disable logging of the parameter.	If enabled parameter will be logged the log files. Parameter will be logged with all its attributes – ‘Min Value’, ‘Average Vale’, ‘Max Value’, ‘Instantaneous Value’, ‘SD Value’ and ‘Integrated Value’
7	IOT	Enable transmission of parameter value via IOT.	<b>‘Disable’</b> : IOT transmission is disabled. <b>‘Value’</b> : Only parameter value is transmitted. <b>‘Value and Stat’</b> : Parameter value and its statistics are also transmitted.

Table-6.16.3.1: Configuration – Voltage input channels

MODBUS Slave register (signed 32 bits) details for voltage input channels is provided in table 6.16.3.2 below.

Sr. No	Datalogger MODBUS Slave Register	Parameter
1	MODBUS Slave Starting Register Address	Parameter Value
2	+2	Parameter minimum Value
3	+4	Parameter maximum Value
4	+6	Parameter average value
5	+8	Parameter standard deviation. This value will be available if it is enabled in configuration. Else this will be ‘0’.
6	+10	Parameter integrated value. This value will be available if it is enabled in configuration. Else this will be ‘0’.

Table-6.16.3.2: Analog input Voltage – MODBUS slave register details

Note:

Quality of voltage measurements is provided in MODBUS Slave register – 10452 (refer section 10.9).

## 6.16.4 Configure – Analog Input Battery Voltage

Select tab ‘Analog Input Battery Voltage’ to enable monitoring of system battery voltage as shown in figure-6.16.4 below.

This tab will be available only if this feature is available in the data logger model.

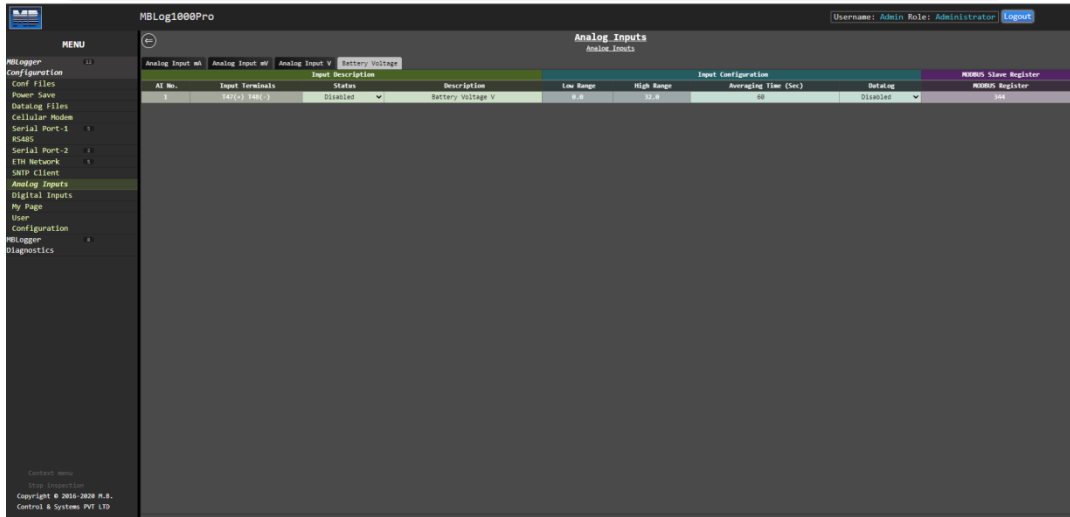

Figure-6.16.4: Monitoring system battery voltage.

Configuration details for battery voltage input channel is provided in table 6.16.4.1 below.

Sr. No	Parameter	Description	Remarks
1	Status	Enable to monitor battery voltage. Disable if this is not required.	Averaging and datalogging can be enabled for battery voltage.

Table-6.16.4.1: Configuration – Battery Voltage monitoring

MODBUS Slave register (32 bits float) details for battery voltage input is provided in table 6.16.4.2 below.

Sr. No	Datalogger MODBUS Slave Register	Parameter	Length
1	MODBUS Slave Starting Register Address	Battery Voltage	32 bits float
2	+2	Battery Voltage minimum Value	32 bits float
3	+4	Battery Voltage maximum Value	32 bits float
4	+6	Battery Voltage average value	32 bits float

Table-6.16.4.2: Analog input Battery Voltage – MODBUS slave register details

Note: Quality of battery voltage measurements is provided in MODBUS Slave register – 10453 (refer section 10.9).

## 6.16.5 Configure – RTD Sensor Input

Select tab ‘RTD PT1000’ or ‘RTD PT100’ to enable monitoring of RTD temperature input as shown in figure-6.16.5 below.

The tab will be see as per the RTD input (PT100 or PT1000) available in the data logger.

This tab will be available only if RTD input is available in the data logger model.

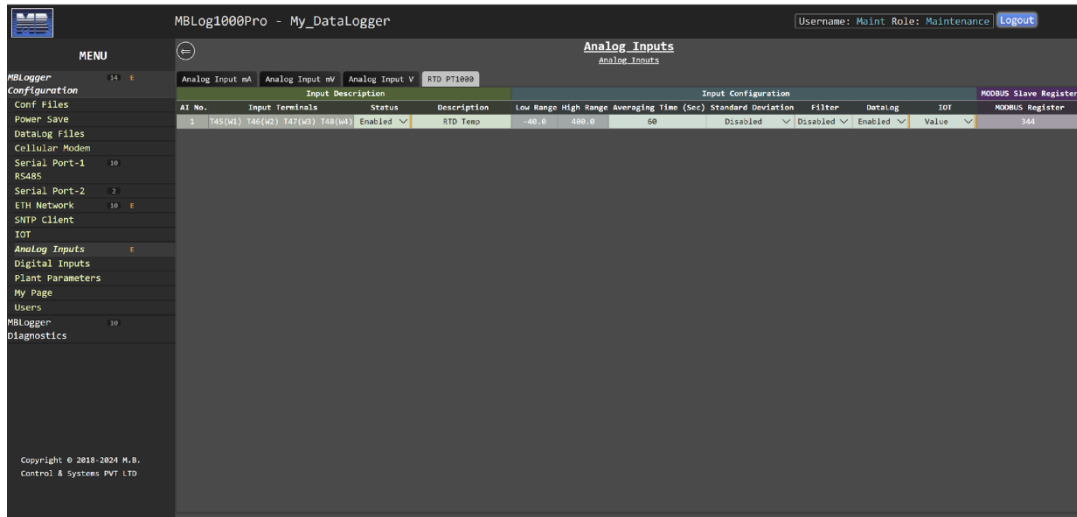

Figure-6.16.5: RTD input configuration.

Configuration details for RTD input channel is provided in table 6.16.5.1 below.

Sr. No	Parameter	Description	Remarks
1	Status	Enable to measure RTD temperature.	Averaging and datalogging can be enabled.
2	Description	RTD description	
3	Low and High Range		Low and High temperature measurement range for the RTD input.
4	Data log	Enable or Disable logging of the parameter.	If enabled parameter will be logged the log files. Parameter will be logged with all its attributes – ‘Min Value’, ‘Average Vale’, ‘Max Value’, ‘Instantaneous Value’ and ‘SD Value’
5	IOT	Enable transmission of parameter value via IOT.	<p><b>‘Disable’</b>: IOT transmission is disabled.</p> <p><b>‘Value’</b>: Only parameter value is transmitted.</p> <p><b>‘Value and Stat’</b>: Parameter value and its statistics are also transmitted.</p>

Table-6.16.5.1: Configuration – RTD temperature monitoring

MODBUS Slave register (32 bits float) details for battery voltage input is provided in table 6.16.5.2 below.

Sr. No	Datalogger MODBUS Slave Register	Parameter	Length
1	MODBUS Slave Starting Register Address	RTD Temperature	32 bits float
2	+2	RTD Temperature minimum Value	32 bits float
3	+4	RTD Temperature maximum Value	32 bits float
4	+6	RTD Temperature average value	32 bits float

Table-6.16.5.2: Analog input RTD Temperature – MODBUS slave register details

Note:

Quality of RTD Temperature measurements is provided in MODBUS Slave register – 10453 (refer section 10.9).

## 6.17 Configure – Digital Inputs

Digital inputs can be configured for following operations:

- i) Status input
- ii) Rain gauge
- iii) Wind speed measurement

Left click on menu option ‘Digital Input’ to configure digital input channels as shown in figure-6.17 below.

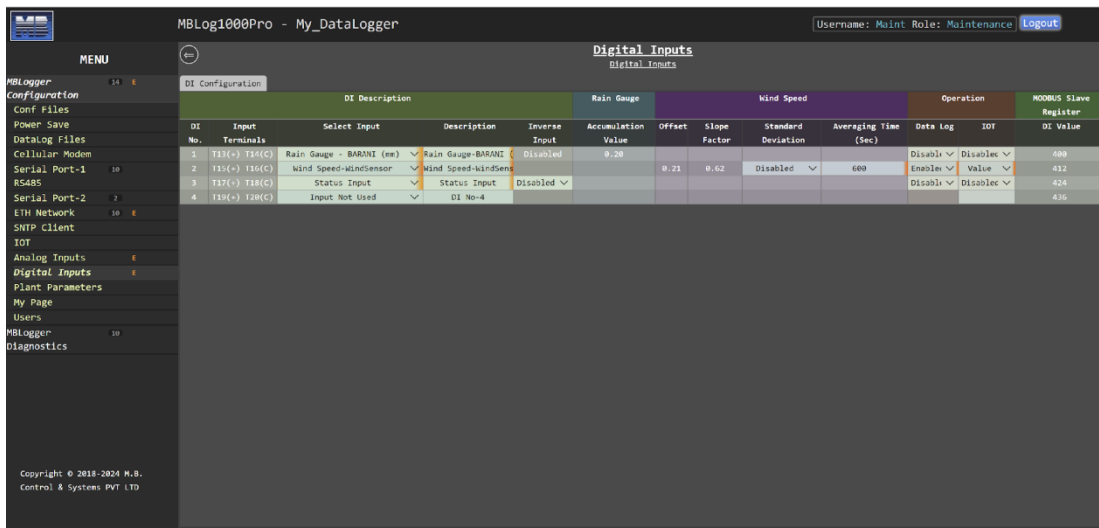

Figure-6.17: Configuration of digital input channels.

Configuration details for digital inputs provided in table 6.17.1 below.

Sr. No	Parameter	Description	Remarks
1	Input Terminals	Data logger terminal numbers for the input channel.	
2	Select Input	Select sensor connected to the digital input. Select 'Input not used' if the input is not used.	Edit of other configuration parameters will be enabled/ disabled based on the selected input type.
3	Rain gauge-Accumulation value		This constant will be multiplied to accumulated rain gauge pulses.
4	Wind Speed parameters		These parameters will be enabled for wind speed sensors.
5	Data Log	Enable or disable data log operation for the input parameter.	
6	IOT	Enable transmission of parameter value via IOT.	'Disable': IOT transmission is disabled. 'Value': Only parameter value is transmitted. 'Value and Stat': Parameter value and its statistics are also transmitted.

Table-6.17.1: Configuration – Digital inputs

MODBUS Slave register (32 bits float) details for digital input channels is provided in table 6.17.2 below.

Sr. No	Datalogger MODBUS Slave Register	Parameter	Length
1	MODBUS Slave Starting Register Address	Digital Input Status for channels configured as status input. Input parameter value (e.g. wind speed or Rain Gauge) as per input configuration.	32 bits float
2	+2	Status change time (epoch second)	32 bits float
3	+4	Input value minimum value	32 bits float
4	+6	Input value maximum value	32 bits float
5	+8	Input value average value	32 bits float
6	+10	Input value standard deviation	32 bits float

Table-6.17.2: Digital input channels – MODBUS slave register details

Note:

Quality of digital measurements is provided in MODBUS Slave register – 10454 (refer section 10.9).

## 6.18 MyPage Parameters

This unique feature allows the user to configure required parameters of interest on one page for viewing on webserver and OLED. Maximum of 36 parameters can be configured. These parameters can also be accessed on MODBUS Slave port in sequential register addresses.

Left click on menu option 'MyPage' to configure analog input channels as shown in figure-6.18 below.

Parameter No.	Parameter Source	My Parameters	Parameter	Parameter Attribute	MODBUS Slave Register
1	Input mA	✓	NBCS PBMet-802 P/Module Temp.	Value	28
2	Input RTD	✓	RTD Temp	Value	22
3	SRI RS485 IED-1 KIPP ZOMEN SWP10	✓	Solar Radiation W/Meters2	Value	24
4	SRI RS485 IED-2 KIPP ZOMEN SWP11	✓	Solar Radiation W/Meters2	Value	26
5	ETH IED-1 Kipp Zomem Razon Plus	✓	Data Averaging Interval End	Value	28
6	ETH IED-1 Kipp Zomem Razon Plus	✓	Time Averaging Interval End	Value	30
7	Not Used	✓	Not Used	Not Used	32
8	Not Used	✓	Not Used	Not Used	34
9	Not Used	✓	Not Used	Not Used	36
10	Not Used	✓	Not Used	Not Used	38
11	Not Used	✓	Not Used	Not Used	40
12	Not Used	✓	Not Used	Not Used	42
13	Not Used	✓	Not Used	Not Used	44
14	Not Used	✓	Not Used	Not Used	46
15	Not Used	✓	Not Used	Not Used	48
16	Not Used	✓	Not Used	Not Used	50
17	Not Used	✓	Not Used	Not Used	52
18	Not Used	✓	Not Used	Not Used	54
19	Not Used	✓	Not Used	Not Used	56
20	Not Used	✓	Not Used	Not Used	58
21	Not Used	✓	Not Used	Not Used	60
22	Not Used	✓	Not Used	Not Used	62
23	Not Used	✓	Not Used	Not Used	64
24	Not Used	✓	Not Used	Not Used	66
25	Not Used	✓	Not Used	Not Used	68
26	Not Used	✓	Not Used	Not Used	70
27	Not Used	✓	Not Used	Not Used	72
28	Not Used	✓	Not Used	Not Used	74
29	Not Used	✓	Not Used	Not Used	76
30	Not Used	✓	Not Used	Not Used	78
31	Not Used	✓	Not Used	Not Used	80
32	Not Used	✓	Not Used	Not Used	82
33	Not Used	✓	Not Used	Not Used	84

Figure-6.18: Configuration of MyPage.

Select the required tab to configure MyPage parameters.

### 6.18.1 My Page – Parameter Configuration

Parameter can be selected from configured sensors/ IED and parameter in the same.

Select tab 'My Parameters' to configure MyPage parameters.

Selection of parameter source is show in figure-6.18.1.1 below.

Parameter No.	Parameter Source	My Parameters	Parameter	Parameter Attribute	MODBUS Slave Register
1	Input mA	✓	NBCS PBMet-802 P/Module Temp.	Value	28
2	Input RTD	✓	RTD Temp	Value	22
3	SRI RS485 IED-1 KIPP ZOMEN SWP10	✓	Solar Radiation W/Meters2	Value	24
4	SRI RS485 IED-2 KIPP ZOMEN SWP11	✓	Solar Radiation W/Meters2	Value	26
5	ETH IED-1 Kipp Zomem Razon Plus	✓	Data Averaging Interval End	Value	28
6	ETH IED-1 Kipp Zomem Razon Plus	✓	Time Averaging Interval End	Value	30
7	Not Used	✓	Not Used	Not Used	32
8	Not Used	✓	Not Used	Not Used	34
9	Not Used	✓	Not Used	Not Used	36
10	Not Used	✓	Not Used	Not Used	38
11	Not Used	✓	Not Used	Not Used	40
12	Not Used	✓	Not Used	Not Used	42
13	Not Used	✓	Not Used	Not Used	44
14	Not Used	✓	Not Used	Not Used	46
15	Not Used	✓	Not Used	Not Used	48
16	Not Used	✓	Not Used	Not Used	50
17	Not Used	✓	Not Used	Not Used	52
18	Not Used	✓	Not Used	Not Used	54
19	Not Used	✓	Not Used	Not Used	56
20	Not Used	✓	Not Used	Not Used	58
21	Not Used	✓	Not Used	Not Used	60
22	Not Used	✓	Not Used	Not Used	62
23	Not Used	✓	Not Used	Not Used	64
24	Not Used	✓	Not Used	Not Used	66
25	Not Used	✓	Not Used	Not Used	68
26	Not Used	✓	Not Used	Not Used	70
27	Not Used	✓	Not Used	Not Used	72
28	Not Used	✓	Not Used	Not Used	74
29	Not Used	✓	Not Used	Not Used	76
30	Not Used	✓	Not Used	Not Used	78
31	Not Used	✓	Not Used	Not Used	80
32	Not Used	✓	Not Used	Not Used	82
33	Not Used	✓	Not Used	Not Used	84

Figure-6.18.1.1: Select Source for MyPage parameters.

Special function parameters can also be added to MyPage parameters if these are available and configured in the datalogger.

Selection of My parameter source is show in figure-6.18.1.2 below.



Figure-6.18.1.2: Select MyPage parameter.

Configuration details for MyPage parameters are provided in table 6.18.1.1 below.

Sr. No	Parameter	Description	Remarks
1	Parameter Source	Select source for the parameter. Dropdown list of configured and enabled sensors and IED's shall be provided.	Select 'Not Used' if parameter configuration is not required. Sensor not enabled will not be listed.
2	Parameter	Select the parameter of interest. Dropdown list of parameters configured in the selected source shall be provided.	Select 'Not Used' if parameter configuration is not required.
3	Parameter Attribute	Select parameter attribute required. Dropdown list of parameter attributes shall be provided based on type the selected parameter.	Select required parameter attribute eg. Value, Value_Maximum, Value_Minimum etc.
4	MODBUS Register	MODBUS register address is provided for external device or SCADA to read value of the parameter.	All parameter values are provided as 32 bits float registers. This field in not editable.

Table-6.18.1.1: MyPage parameters configuration

MODBUS Slave register for MyPage parameters is provided in table 6.18.1.2 below. These parameters can be read via MODBUS Float.

Sr. No	Datalogger MODBUS Slave Register	Parameter
1	MODBUS Slave Starting Register Address	Parameter Value

Table-6.18.1.2: MyPage parameters – MODBUS slave register details

Note: Parameter values which are not configured will be read as '0'.

## 6.19 User Configuration

Following types of users can be configured for datalogger operation:

- i) Administrator
- ii) Operator
- iii) Viewer

Left click on menu option ‘User Configuration’ to configure users shown in figure-6.19 below. Only ‘Administrator’ can configure usernames and their passwords.

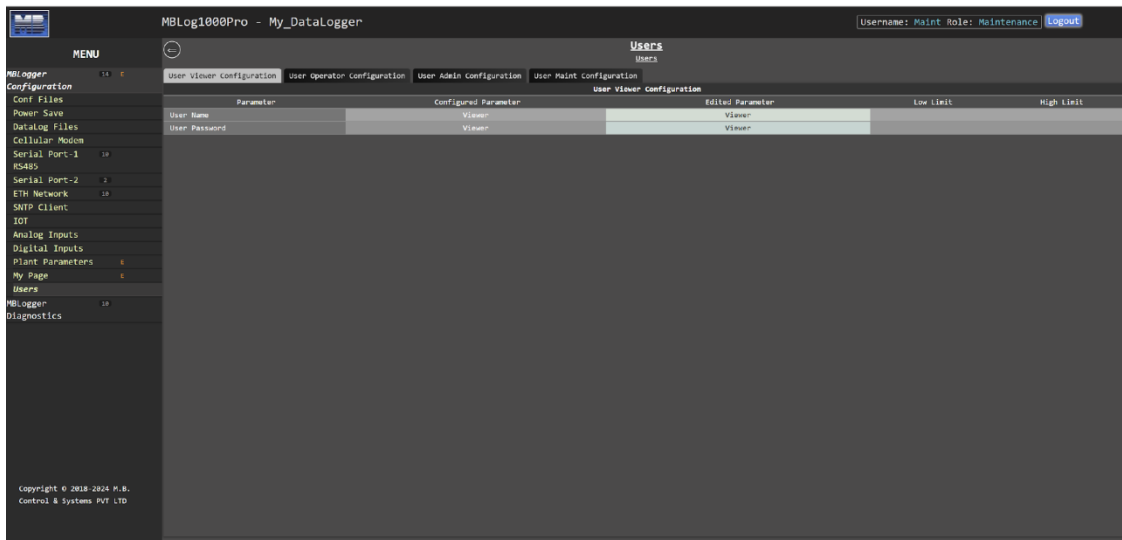

Figure-6.19: User configuration.

Use tabs provided to configure the required user.

Configuration details of user configuration are provided in table 6.16 below.

Sr. No	Parameter	Description	Remarks
1	Username	Set username	Users with configured username and passwords will be allowed to operate the datalogger
2	User Password	Set user password	

Table-6.19: User configuration

## 6.20 Commit Configuration

All edited parameter values must be saved in the datalogger – this is called ‘Commit Operation’. This will be allowed only if configuration of any parameter has been edited (marked by ‘E’).

Following actions will happen (in the listed sequence) once ‘Commit’ is initiated.

- i) All logged in users will be logged out.
- ii) All operations of the datalogger will be stopped. This may take some time.
- iii) New configured valued will be saved in internal non-volatile memory of the datalogger.
- iv) All operations of datalogger will resume with new configuration. This may take some time.
- v) User can login again (if required) with assigned credentials.

Left click on menu option ‘MLogger Configuration’ to select the same. Right click on MLogger Configuration’ to see the submenu option to commit the configuration as shown in figure-6.20 below.

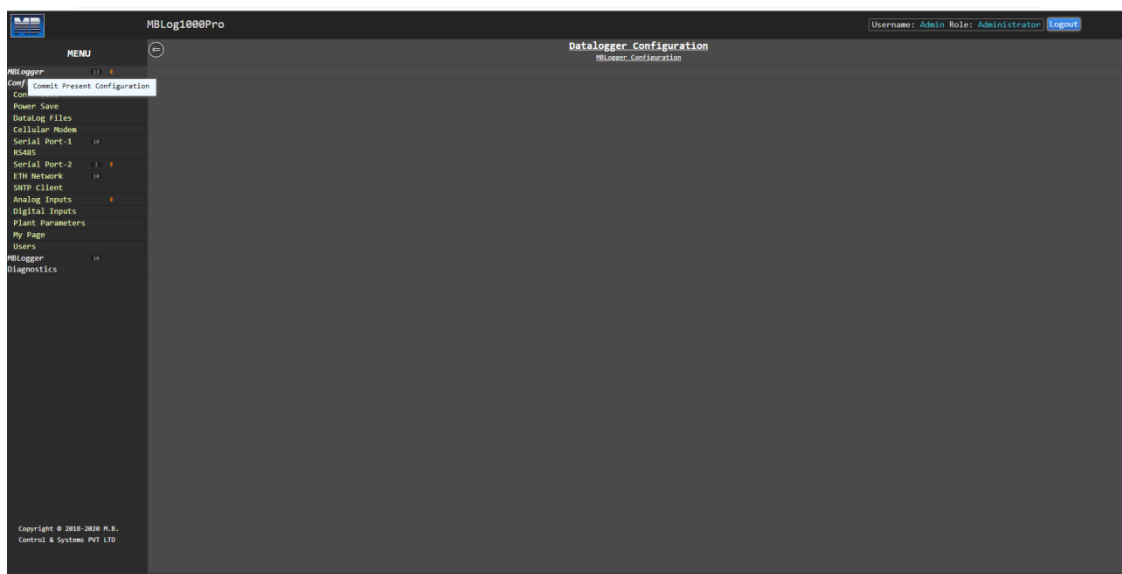

Figure-6.20: Configuration Commit operation.

### Note:

- i) **Once committed, the configuration cannot be reverted. It is irreversible operation. The datalogger must be re-configured if any change is required.**
- ii) **User will be logged out on commit operation. User can login again once the datalogger re-starts.**
- iii) **Datalogger will take few seconds to re-tart its operation.**

## 6.21 Plant Parameters – Special Function

Special functions are added to datalogger to enhance its operational capability. These special functions should be added while the datalogger is ordered.

This special function adds following calculated parameters to the datalogger:

- i) Sunshine duration (requires installation of at least one pyranometer).
- ii) Sunrise and sun set time (requires access to internet via datalogger modem or ETH port).
- iii) Day – solar Energy
- iv) Day – rain measurement
- v) Sunshine duration
- vi) Today solar energy

- vii) Today rainfall
- viii) Albedometer calculations
- ix) Multiple Today Solar Energy

Left click on menu option ‘Plant Parameters’ to configure these parameter as shown in figure-6.21 below. This option will be available only if this special function has been added to the datalogger.

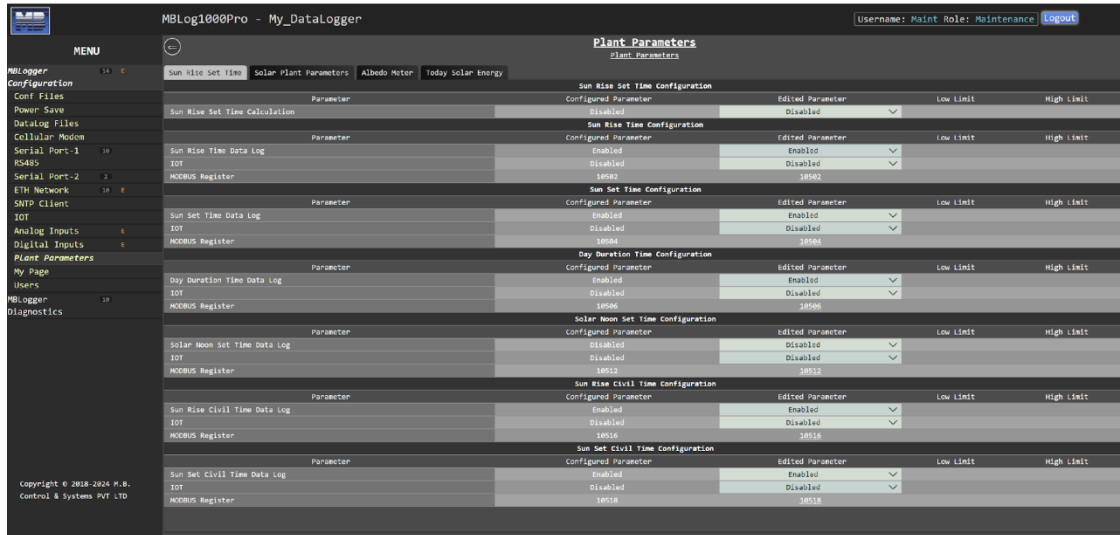

Figure-6.21: Configuration of Plant Parameters (special function).

### 6.21.1 Sun Rise and Set Time

Select tab ‘Sun Rise and Set Time’ to configure its parameters as shown in figure-6.20.1 below.

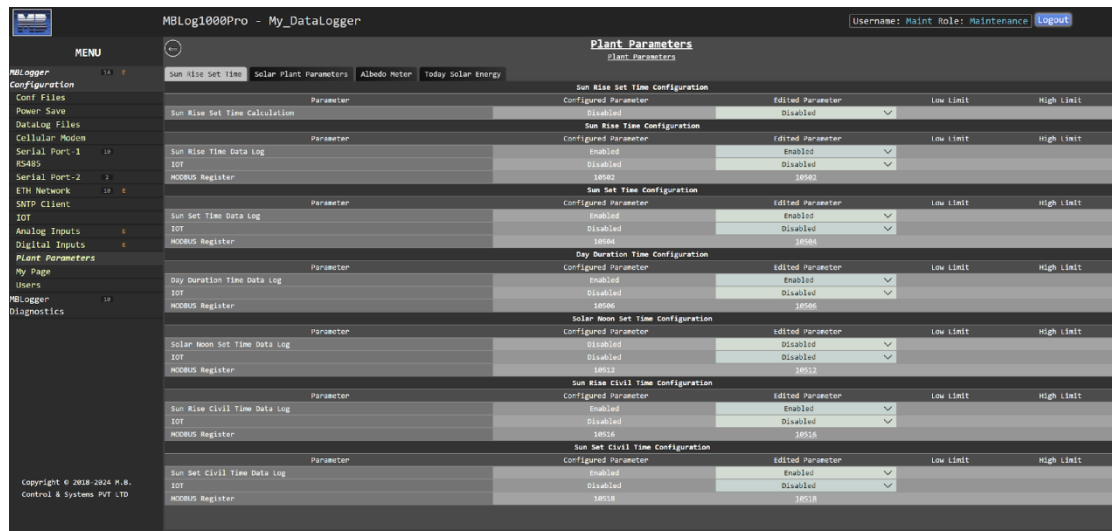

Figure-6.21.1: Configure Sun Rise and Set Time parameters.

Configuration details for sunshine duration parameters are provided in table 6.21.1 below.

Sr. No	Parameter	Description	Remarks
<b>Sun Rise and Set Time Calculation</b>			
1	Sun Rise and Set Time Calculation	Enable or disable	Following parameters should be set for proper calculation of sun rise and set times: Site location coordinates Device time synchronisation
<b>Sun Rise Time / Set Time Configuration</b>			
1	Sun Rise Time / Set Time Data log	Enable or disable	
2	IOT	Enable or disable	Enable for real time value transmission
<b>Day Duration Time Configuration</b>			
1	Day Duration Time Data Log	Enable or disable	Day duration is calculated based on sun rise and set times.
2	IOT	Enable or disable	Enable for real time value transmission
<b>Solar Noon Time Configuration</b>			
1	Solar Noon Time Data Log	Enable or disable	Solar Noon time is calculated based on sun rise and set times.
2	IOT	Enable or disable	Enable for real time value transmission
<b>Sun Rise Time / Set Civil Time Configuration</b>			
1	Sun Rise Time / Set Civil Time Data log	Enable or disable	
2	IOT	Enable or disable	Enable for real time value transmission

Table-6.21.1: Sun rise and set time parameters configuration

### 6.21.2 Solar Plant Parameters

Select tab ‘Solar Plant Parameters’ to configure the parameters as shown in figure-6.21.2 below.

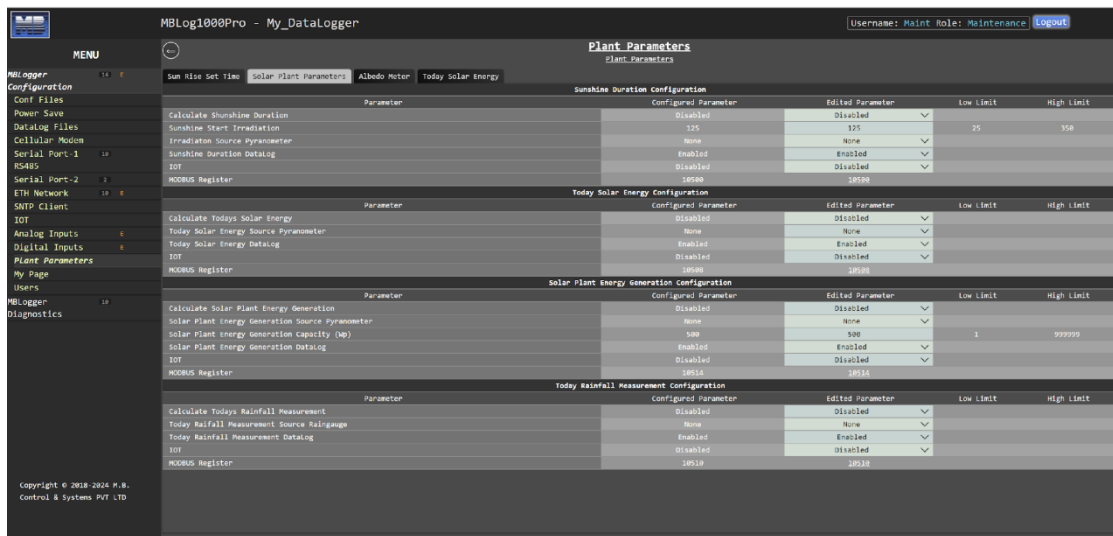

Figure-6.21.2: Configure Solar Plant Parameters.

Configuration details for solar plant parameters are provided in table 6.21.2 below.

Sr. No	Parameter	Description	Remarks
<b>Sunshine Duration Configuration</b>			
1	Sunshine Duration Calculation	Enable or disable	At least one pyranometer should be connected and configured with the data logger.
2	Sunshine start irradiation	Set minimum solar irradiation to detect presence of sunshine.	
3	Sunshine duration data log	Enable or disable	
4	IOT	Enable or disable	Enable for real time value transmission
<b>Today Solar Energy Configuration</b>			
1	Calculate today solar energy	Enable or disable	At least one pyranometer should be connected and configured with the data logger.
2	Today solar energy source pyranometer		Select the pyranometer to be used for calculation of today solar energy
3	Today solar energy data log	Enable or disable	
4	IOT	Enable or disable	Enable for real time value transmission
<b>Solar Plant Generation Configuration</b>			
1	Calculate Solar Plant Generation	Enable or disable	At least one pyranometer should be connected and configured with the data logger.
2	Solar Plant Generation source pyranometer		Select the pyranometer to be used for calculation of today solar energy
3	Solar Plant Generation Capacity (Wp)	Enter solar plant capacity in Wp.	This Wp will be generated at 1.00 Sun.
4	Solar Plant Generation Data Log	Enable or disable	
2	IOT	Enable or disable	Enable for real time value transmission
<b>Today Rainfall Measurement Configuration</b>			
1	Calculate Today Rainfall measurement	Enable or disable	At least one rain gauge should be connected and configured with the data logger.
2	Today Rainfall measurement source rain gauge		Select the rain gauge to be used for calculation of today rainfall
3	Today Rainfall Data Log	Enable or disable	
4	IOT	Enable or disable	Enable for real time value transmission

Table-6.21.2: Solar Plant parameters

### 6.21.3 Albedo Meter

Select tab ‘Albedo Meter’ to configure albedometer parameters as shown in figure-6.21.3 below. Albedo ratio calculations are done based on solar irradiation of upper and lower pyranometers.

Up to four albedo ratios can be calculated.

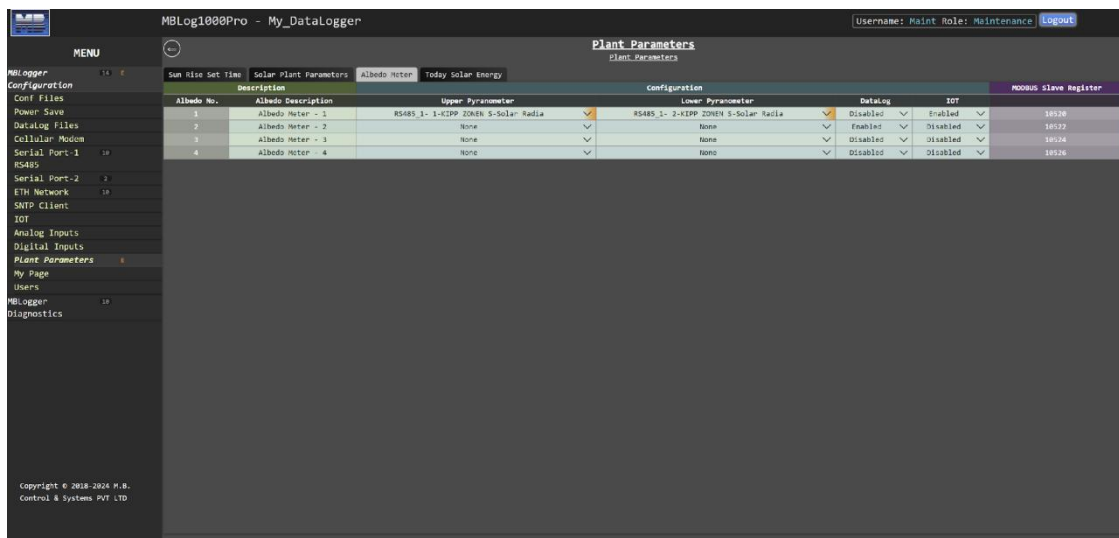

Figure-6.21.3: Configure Albedo Meter parameters.

Configuration details for albedo meters parameters are provided in table 6.21.3 below.

Sr. No	Parameter	Description	Remarks
1	Albedo Meter	Albedo meter description	Albedo ratio will not be calculated if both upper and lower pyranometers are not selected.
2	Upper Pyranometer	Select upper pyranometer from list of pyranometers installed and interfaced with the datalogger.	
3	Lower Pyranometer	Select lower pyranometer from list of pyranometers installed and interfaced with the datalogger.	
4	Data log	Enable or disable	
5	IOT	Enable or disable	Enable for real time value transmission

Table-6.21.3: Albedo meter parameters configuration

## 6.21.4 Today Solar Energy

Select tab 'Today Solar Energy' to configure today solar energy calculation parameters as shown in figure-6.21.4 below.

Up to four today solar energy parameters can be configured.

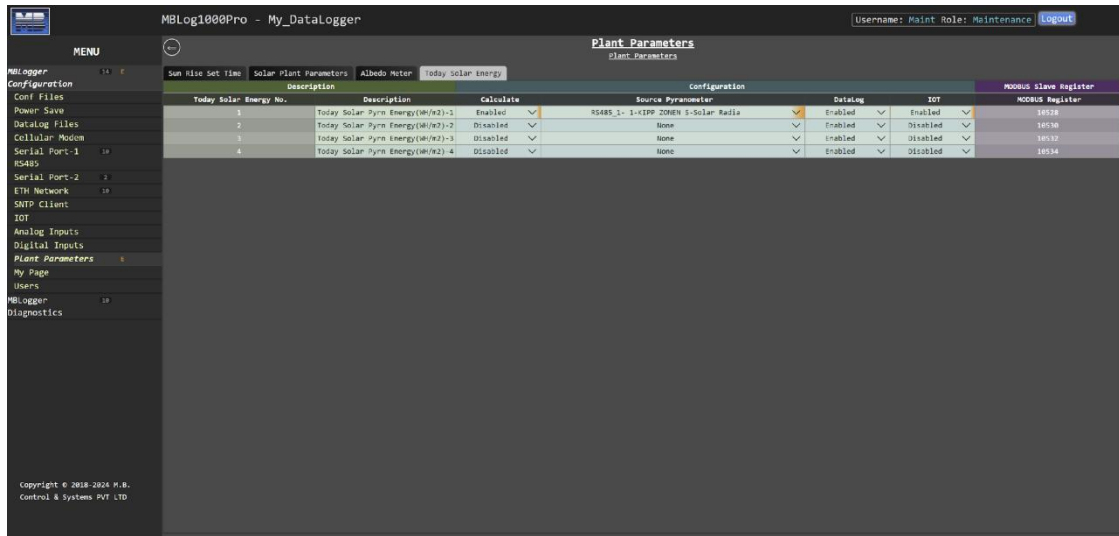

Figure-6.21.4: Configure Today Solar Energy parameters.

Configuration details for today solar energy are provided in table 6.21.4 below.

Sr. No	Parameter	Description	Remarks
1	Description	Today solar energy description	
2	Calculation	Enable or disable	
3	Source Pyranometer	Select pyranometer from list of pyranometers installed and interfaced with the datalogger.	Today solar energy will be calculated based on solar irradiation from this selected pyranometer
4	Data log	Enable or disable	
5	IOT	Enable or disable	Enable for real time value transmission

Table-6.21.4: Today Solar Energy configuration

## 7. Embedded Webserver– Diagnostics

MBLogger provides extensive diagnostics and monitoring functionality via webserver.

Following diagnostic features are provided:

- i) Monitor real time values from all inputs.
- ii) Monitor real time values and communication status of sensors and IED.
- iii) Monitor MyPage parameters
- iv) Status of datalogger resources
- v) Messages from datalogger for user login history, operations, and hardware faults.
- vi) All parameter values, their calculated statistical values and status will be updated in real time (at preset time interval). Animation is provided when the values are updated.
- vii) Parameter values will be updated with their quality. Bad quality values will be shown in red.
- viii) Following communication logs can also be downloaded (by Maintenance Engineer):
  - a. MODBUS communication logs from all ports
  - b. ADC logs
  - c. Modem logs
  - d. MQTT logs
  - e. Data logger status reports
  - f. Data logger value reports

Left click on menu option ‘MBLogger Diagnostic’ to open the diagnostic menu as shown in figure 7 below.



Figure-7: MBLogger diagnostic page.

## 7.1 MBLLogger Status

This status page displays status of datalogger services and modem status:

### 7.1.1 MBLLogger Status

Select tab 'MBLogger Status' to view details of the datalogger and status of services as shown in figure-7.1.1 below.

The screenshot shows the 'MBLogger Diagnostics' page with a table of datalogger status parameters. The table has columns for 'No', 'Description', and 'Status'. The parameters listed are:

No	Description	Status
1	Model	MBLog1000Pro
2	Hardware Version	1.01
3	Software Version	4.001
4	Serial Number	1000000000
5	File Name	MBLog1000
6	No Param Logged	0
7	Media Type	SD Card
8	Media Size (MB)	12800
9	Media Status	Media OK
10	MBLogger IP	192.168.100.100
11	ETH Gateway IP	192.168.100.1
12	Time Zone	UTC+05:30
13	ETH Gateway Status	Link Fail
14	SMTP Client Status	Disabled
15	Day Datalog	Disabled
16	RTT Server-1	Disabled
17	RTT Server-2	Disabled
18	MQTT Broker	Disabled
19	MQTT Client ID	My_MBLLogger
20	MQTT Topic	MBLog1000
21	MQTT Device ID	MBLog1000
22	RTC Date-Time	2020-09-21 10:00:00
23	Run Status	Running

Figure-7.1.1: Datalogger status.

Details for datalogger status are provided in table 7.1.1 below.

Sr. No	Parameter	Description	Remarks
1	Model	Model details of the data logger	
2	Hardware Version	Hardware version for the model	
3	Software Version	Software version for the model	
4	Serial Number	Unique alphanumeric serial number for the datalogger	
5	File Name	Names of data log files	Data log files will be created with this name and will be suffixed by date and time
6	No Param Logged		Number of parameters configured for logging
7	Media Type	SD Card or eMMC	
8	Media Size (MB)		Size of media being used in MB.
9	Media Status	Status of media being used	Display –‘Media OK’, ‘Installed’ or ‘Not Installed’
10	MBLogger IP	IP address for the datalogger	
11	ETH Gateway IP	IP address for the gateway	

12	Time Zone	Country configured for time zone	
13	ETH Gateway Status	Status of link with the network gateway	'Link Fail' or 'Link OK'
14	SNTP Client Status	Status of SNTP client	Display status of SNTP client.
15	Day Data log	Status of day data log	
16	RFT Server-1 and -2	Status of remote file transfer servers	
17	MQTT Broker	Status of connection with MQTT broker	'Disabled', 'Connected' or 'Failed'
18	MQTT Client ID		
19	MQTT Topic		
20	MQTT Device ID		
21	RTC Date - Time		Time and date in the device RTC
22	Sun Status	Status of sun detection	'Disabled', 'Sun Present' or 'Sun Not Present'.

Table-7.1.1: Datalogger status

### 7.1.2 MBLLogger Modem Status

Select tab 'Modem Status' to view status of datalogger internal modem as shown in figure-7.1.2 below.



Figure-7.1.2: Datalogger modem status.

Details for datalogger modem status are provided in table 7.1.2 below.

Sr. No	Parameter	Description	Remarks
1	Modem Status Time		Time at which modem status has been updated.
2	Modem SIM Status		Indicates if the SIM is present or not present.

3	Initialisation Status	Modem initialisation status	
4	Registration status	Modem registration status	
5	Service Provider		Service provider details
6	Operating mode	Modem operation mode	Modem network operation mode – ‘None’, ‘GSM’, ‘GPRS’, ‘EDGE, or ‘LTE’
7	Signal Strength	Cellular signal strength	Signal strength in dBm
8	Bit error rate (BER)	Bit error rate	
9	Modem PPP link Status		Status of modem PPP link.

Table-7.1.2: Datalogger modem status

### 7.1.3 MBLLogger GPS Status

Select tab ‘GPS Status’ to view status of datalogger GPS as shown in figure-7.1.3 below.

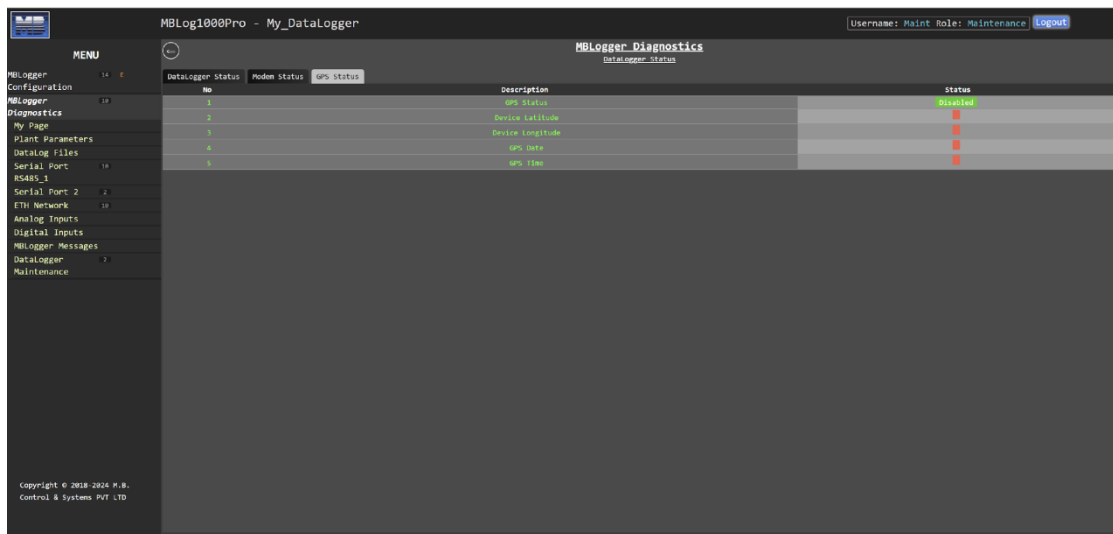

Figure-7.1.3: Datalogger GPS status.

Details for datalogger GPS status are provided in table 7.1.3 below.

Sr. No	Parameter	Description	Remarks
1	GPS Status	GPS status	
2	Device Latitude	Device coordinates obtained from GPS	
3	Device Longitude		
4	GPS Date	Date and Time obtained via GPS	Signal strength in dBm
5	GPS Time		

Table-7.1.3: Datalogger modem status

## 7.2 MyPage Parameters

Left click on diagnostic menu option ‘MyPage Parameters’ to view MyPage parameters as shown in figure 7.2 below.



The screenshot shows the 'My Page' parameters table in the MBLog1000Pro software. The table has columns for Parameter No., Parameter Source, Parameter, Parameter Attribute, and Parameter Value. The first few rows show parameters like Input HI, Input HI, and Kipp Zonen Sensor, with values ranging from -1152.000 to 0.000. Most other parameters are listed as 'Not Used'.

Parameter No.	Parameter Source	Parameter	Parameter Attribute	Parameter Value
1	Input HI	MBLog1000 PIModule Temp.	Value	-1152.000
2	Input HI	HI Temp	Value	-1152.000
3	Kipp Zonen Sensor	Solar Radiation W/meters <sup>2</sup>	Value	0.000
4	Kipp Zonen Sensor	Solar Radiation W/meters <sup>2</sup>	Value	0.000
5	Kipp Zonen Reason Plus	Date Averaging Interval End	Value	0.000
6	Kipp Zonen Reason Plus	Time Averaging Interval End	Value	0.000
7	Not Used	Not Used		
8	Not Used	Not Used		
9	Not Used	Not Used		
10	Not Used	Not Used		
11	Not Used	Not Used		
12	Not Used	Not Used		
13	Not Used	Not Used		
14	Not Used	Not Used		
15	Not Used	Not Used		
16	Not Used	Not Used		
17	Not Used	Not Used		
18	Not Used	Not Used		
19	Not Used	Not Used		
20	Not Used	Not Used		
21	Not Used	Not Used		
22	Not Used	Not Used		
23	Not Used	Not Used		
24	Not Used	Not Used		
25	Not Used	Not Used		
26	Not Used	Not Used		
27	Not Used	Not Used		
28	Not Used	Not Used		
29	Not Used	Not Used		
30	Not Used	Not Used		
31	Not Used	Not Used		
32	Not Used	Not Used		
33	Not Used	Not Used		
34	Not Used	Not Used		

Figure-7.2: MyPage parameters.

The values of all parameters configured as MyPage Parameters will be displayed on the page.

## 7.3 Plant Parameter Values – Special Functions

Left click on diagnostic menu option ‘Plant Parameters’ to monitor these values in real time. This option will be provided if the license for the function is installed in the data logger.

### 7.3.1 Plant Parameters

Left click on tab ‘Plant Parameters’ to monitor these parameter values in real time as shown in figure 7.3.1 below.



The screenshot shows the 'Plant Parameters' table in the MBLog1000Pro software. The table has columns for No., Albedo Meter Value, Today Solar Energy Value, Parameter, and Value. The first few rows show parameters like Albedo Meter Value, Today Solar Energy Value, and various sensor readings, with values ranging from 0.000 to 1152.000.

No.	Albedo Meter Value	Today Solar Energy Value	Parameter	Value
1			Albedo Meter Value	1152.000
2			Today Solar Energy Value	1152.000
3			Today Solar Energy Value	1152.000
4			Today Solar Energy Value	1152.000
5			Today Solar Energy Value	1152.000
6			Today Solar Energy Value	1152.000
7			Today Solar Energy Value	1152.000
8			Today Solar Energy Value	1152.000
9			Today Solar Energy Value	1152.000
10			Today Solar Energy Value	1152.000
11			Today Solar Energy Value	1152.000
12			Today Solar Energy Value	1152.000
13			Today Solar Energy Value	1152.000
14			Today Solar Energy Value	1152.000
15			Today Solar Energy Value	1152.000
16			Today Solar Energy Value	1152.000
17			Today Solar Energy Value	1152.000
18			Today Solar Energy Value	1152.000
19			Today Solar Energy Value	1152.000
20			Today Solar Energy Value	1152.000
21			Today Solar Energy Value	1152.000
22			Today Solar Energy Value	1152.000
23			Today Solar Energy Value	1152.000
24			Today Solar Energy Value	1152.000
25			Today Solar Energy Value	1152.000
26			Today Solar Energy Value	1152.000
27			Today Solar Energy Value	1152.000
28			Today Solar Energy Value	1152.000
29			Today Solar Energy Value	1152.000
30			Today Solar Energy Value	1152.000
31			Today Solar Energy Value	1152.000
32			Today Solar Energy Value	1152.000
33			Today Solar Energy Value	1152.000
34			Today Solar Energy Value	1152.000

Figure-7.3.1: Plant parameter values

The values of the configured plant parameters will be displayed and updated on this page.

### 7.3.2 Albedometer Values

Left click on tab 'Albedometer Values' to monitor configured albedo ratios values in real time as shown in figure 7.3.2 below.

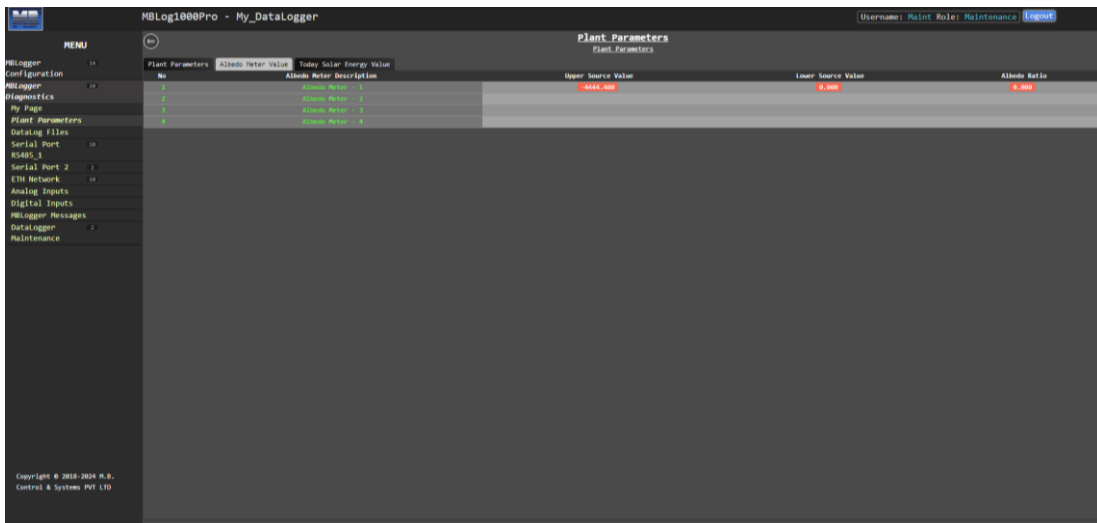

Figure-7.3.2: Albedo ratio values

### 7.3.3 Today Solar Energy Values

Left click on tab 'Today Solar Energy Values' to monitor configured today solar energy ratios values as shown in figure 7.3.3 below.

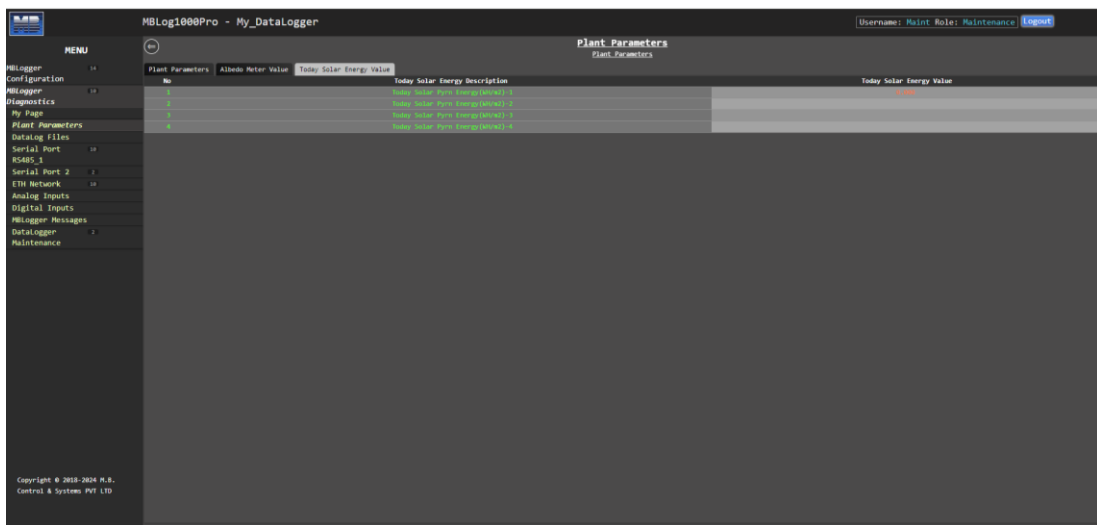

Figure-7.3.3: Today solar energy values

## 7.4 Data Log Files

Status of all data log files can be viewed via this page. Files can also be deleted or downloaded via click buttons provided.

Left click on diagnostic menu option ‘Datalog Files’ to view details of logged files.

Three tabs are provided for data log files:

- i) ‘Data log Files’: Data log files.
- ii) ‘Data log Files RFT-1’: Data log files for remote file server-1.
- iii) ‘Data log Files RFT-2’: Data log files for remote file server-2.

### 7.4.1 Data Log Files

Day log file status is shown in figure 7.4.1 below.

Newer messages will be displayed first.

The screenshot shows the MBLog1000Pro software interface. The main window is titled 'Datalog Files' and contains a table with the following columns: No, File Name, Time, Size(Bytes), Download Status, File Delete, and File Download. The table lists various log files with their corresponding details. The interface also includes a menu on the left and a user information bar at the top right.

Figure-7.4.1: Data log files

Details file status and operation are provided in table 7.4.1 below.

Sr. No	Parameter	Description	Remarks
1	File name	Logged file name	
2	Time	File log time	
3	Size	File size in Bytes	
4	Download Status	Download status of the file	File not downloaded – ‘File Not Downloaded’. File downloaded – ‘Downloaded’.
4	Delete File button	Left click on the button to delete the file.	Files delete operation is irreversible. ‘Delete Button’ shall be disabled for the Active file (file that is being logged).
5	Download File button	Left click on the button to download the file.	The file will be downloaded to PC. This button will not be available if the file is being logged.

Table-7.4.1: Data log files

## 7.4.2 DataLog Files RFT-1 and RFT-2

Select the required tab for viewing status of remote file transfer operation.  
Remote Transfer log file status is shown in figure 7.4.2 below.

No.	File Name	Time	Size(Bytes)	Transmit Status	Download Status	File Delete	File Download
1	MBLog1000_11.08.11.00.00	2011-11-08 11:00:00	4000	File Transmitted	File Not Downloaded	Delete File	Download File
2	MBLog1000_11.08.11.00.00	2011-11-08 11:00:00	4000	File Transmitted	File Not Downloaded	Delete File	Download File
3	MBLog1000_11.08.11.00.00	2011-11-08 11:00:00	4000	File Transmitted	File Not Downloaded	Delete File	Download File
4	MBLog1000_11.08.11.00.00	2011-11-08 11:00:00	4000	File Transmitted	File Not Downloaded	Delete File	Download File
5	MBLog1000_11.08.11.00.00	2011-11-08 11:00:00	4000	File Transmitted	File Not Downloaded	Delete File	Download File
6	MBLog1000_11.08.11.00.00	2011-11-08 11:00:00	4000	File Transmitted	File Not Downloaded	Delete File	Download File
7	MBLog1000_11.08.11.00.00	2011-11-08 11:00:00	4000	File Transmitted	File Not Downloaded	Delete File	Download File
8	MBLog1000_11.08.11.00.00	2011-11-08 11:00:00	4000	File Transmitted	File Not Downloaded	Delete File	Download File
9	MBLog1000_11.08.11.00.00	2011-11-08 11:00:00	4000	File Transmitted	File Not Downloaded	Delete File	Download File
10	MBLog1000_11.08.11.00.00	2011-11-08 11:00:00	4000	File Transmitted	File Not Downloaded	Delete File	Download File
11	MBLog1000_11.08.11.00.00	2011-11-08 11:00:00	4000	File Transmitted	File Not Downloaded	Delete File	Download File
12	MBLog1000_11.08.11.00.00	2011-11-08 11:00:00	4000	File Transmitted	File Not Downloaded	Delete File	Download File
13	MBLog1000_11.08.11.00.00	2011-11-08 11:00:00	4000	File Transmitted	File Not Downloaded	Delete File	Download File
14	MBLog1000_11.08.11.00.00	2011-11-08 11:00:00	4000	File Transmitted	File Not Downloaded	Delete File	Download File
15	MBLog1000_11.08.11.00.00	2011-11-08 11:00:00	4000	File Transmitted	File Not Downloaded	Delete File	Download File
16	MBLog1000_11.08.11.00.00	2011-11-08 11:00:00	4000	File Transmitted	File Not Downloaded	Delete File	Download File
17	MBLog1000_11.08.11.00.00	2011-11-08 11:00:00	4000	File Transmitted	File Not Downloaded	Delete File	Download File
18	MBLog1000_11.08.11.00.00	2011-11-08 11:00:00	4000	File Transmitted	File Not Downloaded	Delete File	Download File
19	MBLog1000_11.08.11.00.00	2011-11-08 11:00:00	4000	File Transmitted	File Not Downloaded	Delete File	Download File
20	MBLog1000_11.08.11.00.00	2011-11-08 11:00:00	4000	File Transmitted	File Not Downloaded	Delete File	Download File
21	MBLog1000_11.08.11.00.00	2011-11-08 11:00:00	4000	File Transmitted	File Not Downloaded	Delete File	Download File
22	MBLog1000_11.08.11.00.00	2011-11-08 11:00:00	4000	File Transmitted	File Not Downloaded	Delete File	Download File
23	MBLog1000_11.08.11.00.00	2011-11-08 11:00:00	4000	File Transmitted	File Not Downloaded	Delete File	Download File
24	MBLog1000_11.08.11.00.00	2011-11-08 11:00:00	4000	File Transmitted	File Not Downloaded	Delete File	Download File
25	MBLog1000_11.08.11.00.00	2011-11-08 11:00:00	4000	File Transmitted	File Not Downloaded	Delete File	Download File
26	MBLog1000_11.08.11.00.00	2011-11-08 11:00:00	4000	File Transmitted	File Not Downloaded	Delete File	Download File
27	MBLog1000_11.08.11.00.00	2011-11-08 11:00:00	4000	File Transmitted	File Not Downloaded	Delete File	Download File
28	MBLog1000_11.08.11.00.00	2011-11-08 11:00:00	4000	File Transmitted	File Not Downloaded	Delete File	Download File
29	MBLog1000_11.08.11.00.00	2011-11-08 11:00:00	4000	File Transmitted	File Not Downloaded	Delete File	Download File
30	MBLog1000_11.08.11.00.00	2011-11-08 11:00:00	4000	File Transmitted	File Not Downloaded	Delete File	Download File
31	MBLog1000_11.08.11.00.00	2011-11-08 11:00:00	4000	File Transmitted	File Not Downloaded	Delete File	Download File
32	MBLog1000_11.08.11.00.00	2011-11-08 11:00:00	4000	File Transmitted	File Not Downloaded	Delete File	Download File
33	MBLog1000_11.08.11.00.00	2011-11-08 11:00:00	4000	File Transmitted	File Not Downloaded	Delete File	Download File
34	MBLog1000_11.08.11.00.00	2011-11-08 11:00:00	4000	File Transmitted	File Not Downloaded	Delete File	Download File
35	MBLog1000_11.08.11.00.00	2011-11-08 11:00:00	4000	File Transmitted	File Not Downloaded	Delete File	Download File
36	MBLog1000_11.08.11.00.00	2011-11-08 11:00:00	4000	File Transmitted	File Not Downloaded	Delete File	Download File
37	MBLog1000_11.08.11.00.00	2011-11-08 11:00:00	4000	File Transmitted	File Not Downloaded	Delete File	Download File
38	MBLog1000_11.08.11.00.00	2011-11-08 11:00:00	4000	File Transmitted	File Not Downloaded	Delete File	Download File
39	MBLog1000_11.08.11.00.00	2011-11-08 11:00:00	4000	File Transmitted	File Not Downloaded	Delete File	Download File
40	MBLog1000_11.08.11.00.00	2011-11-08 11:00:00	4000	File Transmitted	File Not Downloaded	Delete File	Download File

Figure-7.4.2: Remote transfer data log file status

Details file status and operation are provided in table 7.4.2 below.

Sr. No	Parameter	Description	Remarks
1	File name	Logged file name	
2	Time	File log time	
3	Size	File size in Bytes	
4	Transmit status	Transmit status of the file	File not transmitted – ‘Not Transmitted’. File not transmitted – ‘Transmitted’.
5	Download Status	Download status of the file	File not downloaded – ‘File Not Downloaded’. File downloaded – ‘Downloaded’.
6	Delete File button	Left click on the button to delete the file.	File delete operation is irreversible. Active file – file that is being logged cannot be deleted. ‘Delete Button’ shall be disabled for this file.
7	Download File– button	Left click on the button to download the file.	The file will be downloaded to PC or Laptop. Status of the file will be changed to ‘Downloaded’. This button will not be available if the file is being transmitted or being logged.

Table-7.4.2: Remote transfer data log files

### 7.4.3 Delete All Data Log Files

Option has been provided to delete all logged files from the selected data log folder as shown in figure 7.4.3 below.



Figure-7.4.3: Delete all log files

Select the folder to delete all logged files. All the logged files in the selected folder will be deleted and it will not be possible to recover the same.

This operation may take some time depending on the number of files in the selected folder.

### 7.4.4 Format Media

SD card or eMMC media can be formatted by right clicking on 'Datalog Files' as shown in figure 7.4.4 below.



Figure-7.4.4: Format data log media

Select option 'Format Media' to format the media. All the logged files on the media will be lost and it will not be possible to recover the same.

*Media format operation once started cannot be stopped. Power supply to the data logger should not be switched off during this operation.*

This operation may take five to fifteen minutes depending on the media type and its size.

## 7.5 Sensor / IED Parameters

Real time communication status and parameter values can be viewed from all the configured sensors and IED.

Follow the steps below to view the IED parameters.

- i) Left click on the port (diagnostic menu) to which the Sensor/ IED is connected. A list of IED will be provided below the port.
  - ii) Left click on the sensor/ IED to view communication status and parameters.
- Use tabs provided to view communication status or parameters.

### 7.5.1 Sensor/ IED Communication Status

Select tab 'IED Communication Status' to view IED communication status as shown in figure-7.5.1 below.

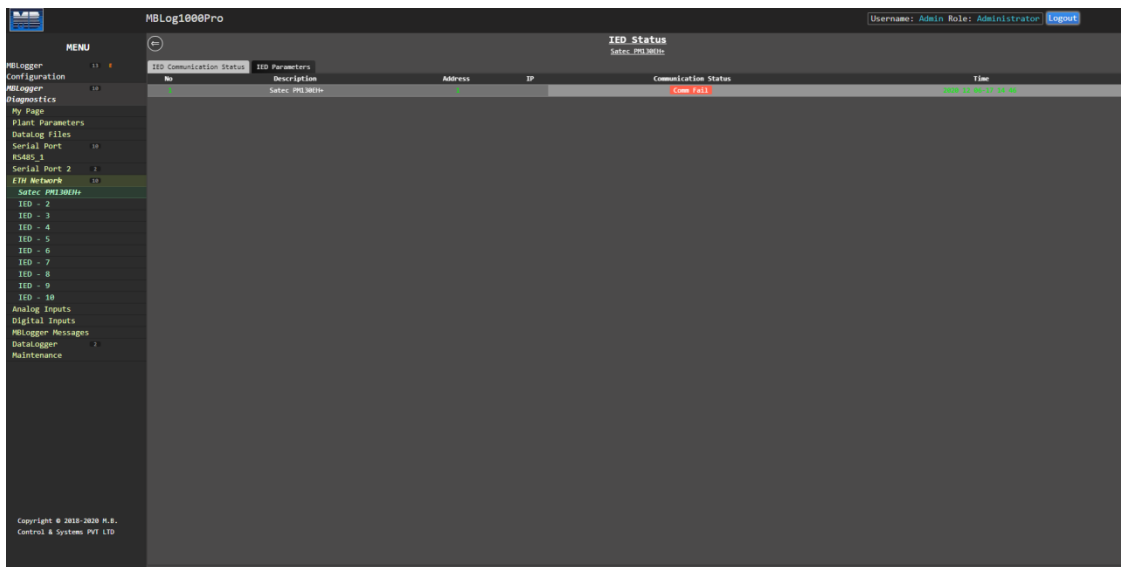

Figure-7.5.1: Sensor/ IED communication status

Communication status of sensor/ IED will be displayed in real time.

Communication details are provided in table 7.5.1 below.

Sr. No	Parameter	Description	Remarks
1	Address	MODBUS address of the sensor/ IED	
2	IP	IP address of sensor / IED shall be provided if these are connected to ETH port.	

Table-7.5.1: Communication status

## 7.5.2 Sensor/ IED Parameter Values

Select tab ‘IED Parameters’ to view sensor/ IED parameter values as shown in figure-7.5.2 below.

No.	Description	Address	Parameter Value	Minimum Value	Average Value	Maximum Value	Standard Deviation	Integrated Value
1	IED - 1	1000	0.000	0.000	0.000	0.000	0.000	0.000
2	IED - 2	1001	0.000	0.000	0.000	0.000	0.000	0.000
3	IED - 3	1002	0.000	0.000	0.000	0.000	0.000	0.000
4	IED - 4	1003	0.000	0.000	0.000	0.000	0.000	0.000
5	IED - 5	1004	0.000	0.000	0.000	0.000	0.000	0.000
6	IED - 6	1005	0.000	0.000	0.000	0.000	0.000	0.000
7	IED - 7	1006	0.000	0.000	0.000	0.000	0.000	0.000
8	IED - 8	1007	0.000	0.000	0.000	0.000	0.000	0.000
9	IED - 9	1008	0.000	0.000	0.000	0.000	0.000	0.000
10	IED - 10	1009	0.000	0.000	0.000	0.000	0.000	0.000

Figure-7.5.2: Sensor/ IED parameter values

Parameter values read from sensor/ IED will be displayed in real time.

Parameter details are provided in table 7.5.2 below.

Sr. No	Parameter	Description	Remarks
1	Address	MODBUS register address of the parameters	
2	Value	Value read from the sensor/ IED	Parameter values and calculated statistical parameters will be updated in real time. Bad quality parameter valued will be in red.

Table-7.5.2: Sensor/ IED parameter values

## 7.6 Analog Input Channels

Real time values from analog input channels can be monitored on this page.

Left click on diagnostic menu option ‘Analog Values’ to view measured values from analog input channels.

Use tabs provided to view analog input values.

### 7.6.1 Measured –Input mA Value

Select tab ‘Input mA Value’ to view measured values from mA input channels as shown in figure-7.6.1 below.

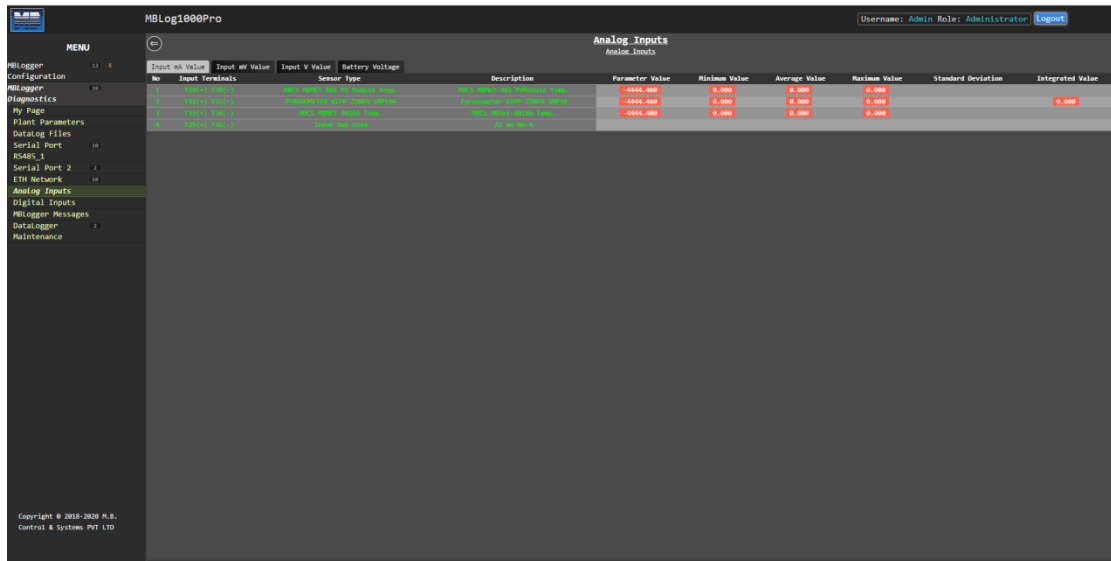

No	Input Channels	Sensor Type	Description	Parameter Value	Minimum Value	Average Value	Maximum Value	Standard Deviation	Integrated Value
1	AI01-001	4-20mA	AI01-001	-4444.400	0.000	0.000	0.000		0.000
2	AI02-001	4-20mA	AI02-001	-4444.400	0.000	0.000	0.000		0.000
3	AI03-001	4-20mA	AI03-001	-4444.400	0.000	0.000	0.000		0.000

Figure-7.6.1: Measure values from mA input channels

Parameter values will be updated in real time with animation.

If the current loop is broken or the sensor is not connected value -4444.4 shall be displayed.

### 7.6.2 Measured –Input mV Value

Select tab ‘Input mV Value’ to view measured values from mV input channels as shown in figure-7.6.2 below.

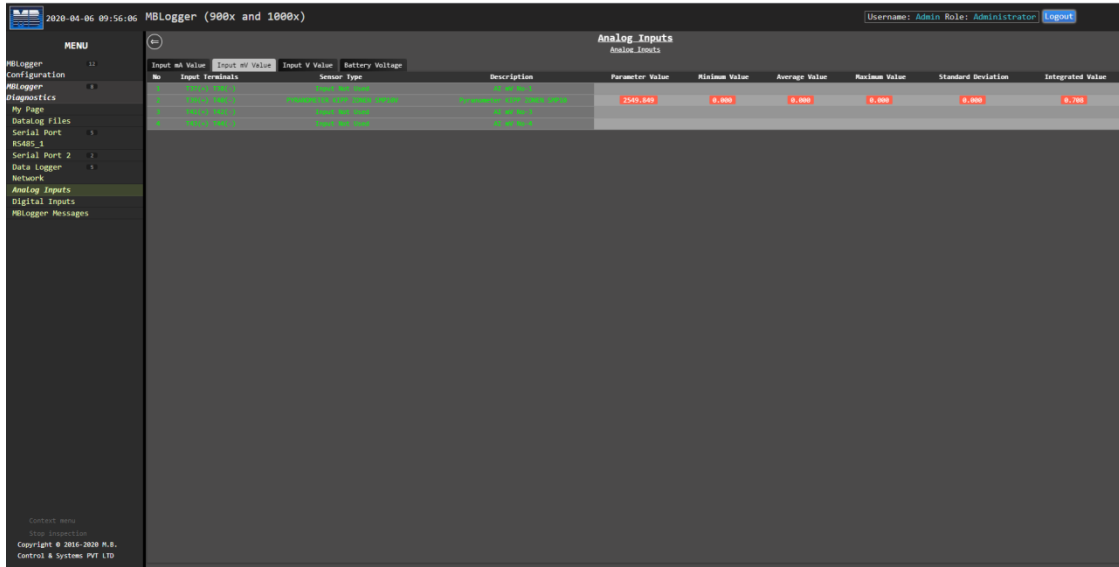

Figure-7.6.2: Measure values from mV input channels

### 7.6.3 Measured –Input Voltage Value

Select tab ‘Input V Value’ to view measured values from Voltage input channels as shown in figure-7.6.3 below.

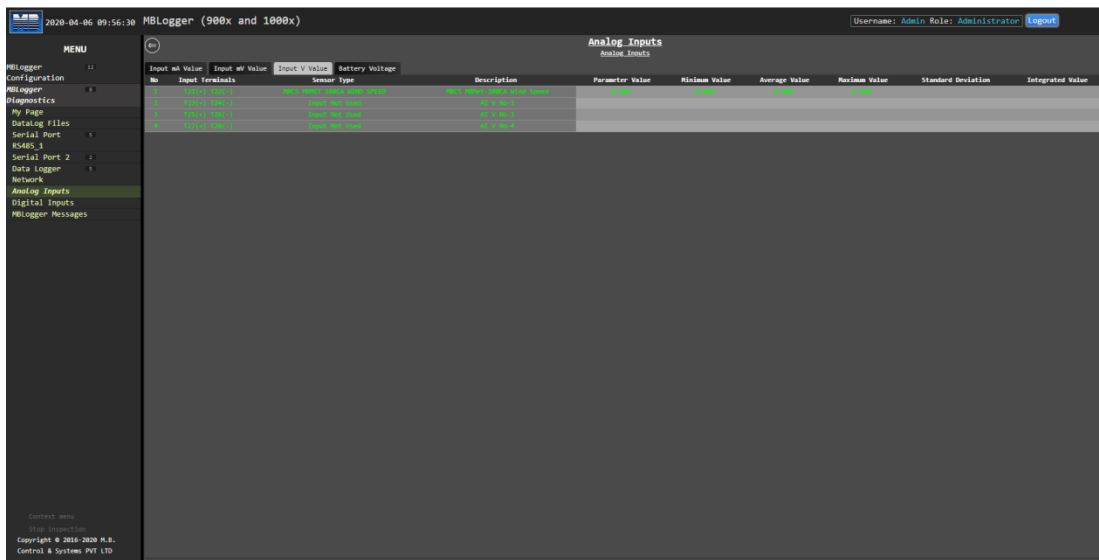

Figure-7.6.3: Measure values from voltage input channels

## 7.6.4 Measured –Battery Voltage

Select tab ‘Battery Voltage’ to view measured system battery voltage as shown in figure-7.6.4 below.

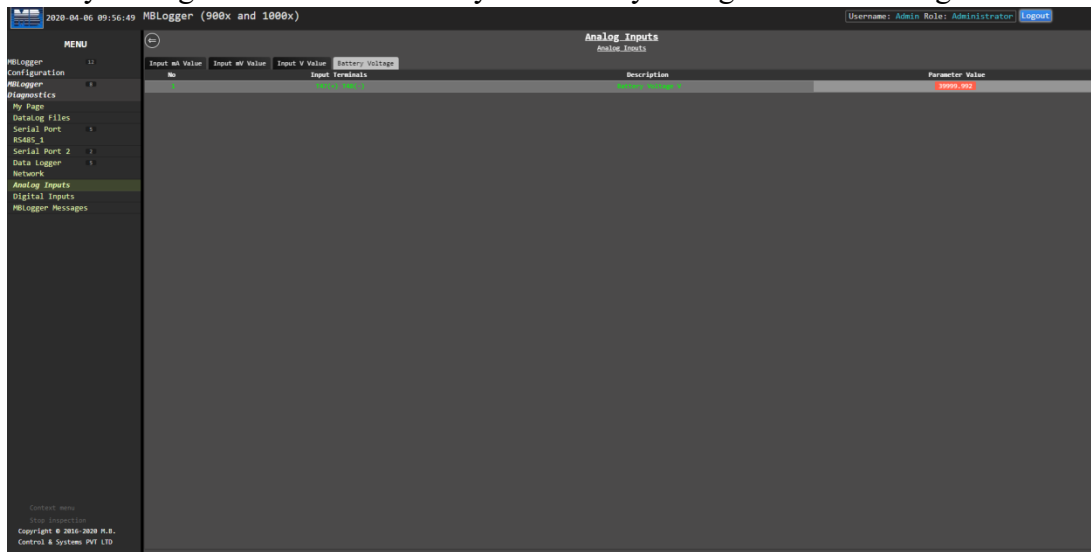

Figure-7.6.4: Measure system battery voltage

## 7.6.5 Measured –RTD Temperature Values

Select tab ‘PT100’ or ‘PT1000’ to view RTD temperature as shown in figure-7.6.5 below. Tab ‘PT100’ or ‘PT1000’ will be displayed depending on type of input available in the data logger. (to be corrected)

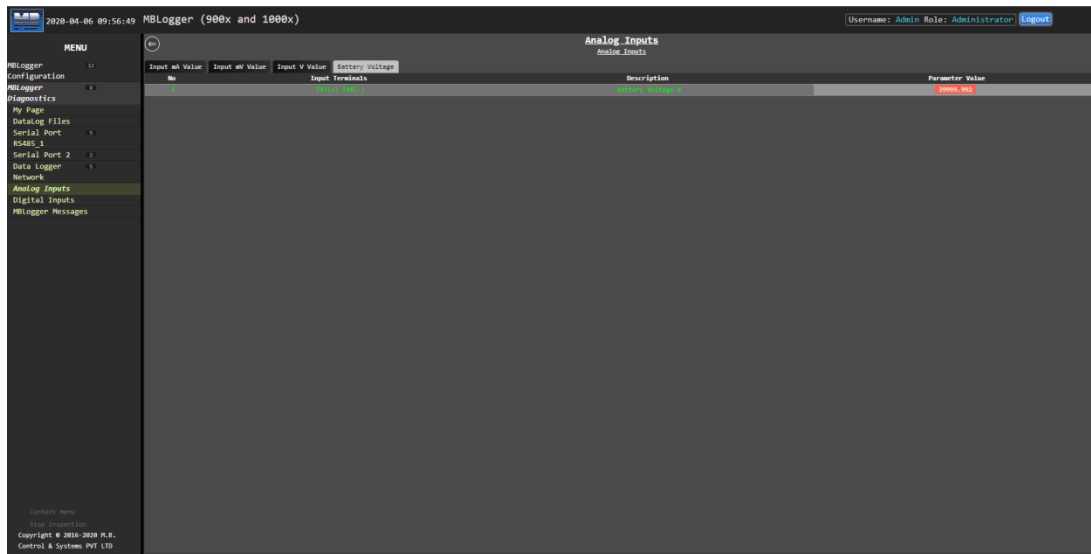

Figure-7.6.5: RTD temperature

## 7.7 Digital Inputs

Left click on diagnostic menu option ‘Digital Inputs’ to monitor digital inputs in real time as shown in figure 7.7 below.

No.	Input Terminals	Description	Status	Calculated Value	Minimum Value	Average Value	Maximum Value	Standard Deviation	Time	Reset
1	DIGITAL INPUT	RAIN GAUGE (WIND SPEED)	ON	0.000					2020 12 06-13 12:56	Reset
2	DIGITAL INPUT	WIND SPEED (RAIN GAUGE)	ON	0.000	0.000	0.000	0.000		2020 12 06-17 16:17	Reset

Figure-7.7: Digital input status/ values

Details of digital input status and values are provided in table 7.7 below.

Sr. No	Parameter	Description	Remarks
1	Status	Status of digital input ‘On’ or ‘Off’	Status is displayed only for digital input channels configured as digital input
2	Calculated Value	Calculated values will be displayed for channels interfaced to Rain Gauges, Windspeed sensor	Calculated statistical values will be displayed if applicable.

Table-7.7: Digital Input status/ values

## 7.8 MLogger Operation Messages

Left click on diagnostic menu option ‘MLogger Messages’ to view fault and information messages from datalogger as shown in figure 7.8 below.

Logged messages shall be displayed on the page. MLogger operation message details are provided in [this chapter](#).

These messages are saved in internal nonvolatile memory.



Figure-7.8: Datalogger messages

Details of datalogger messages are provided in table 7.8 below.

Sr. No	Parameter	Description	Remarks
1	Description	Message description	Hardware faults will be displayed in red.
2	Message Code	Message code	

Table-7.8: Datalogger messages

## 7.9 Datalogger Diagnostics Configuration

MLogger provides extensive diagnostics features to analyze any maloperation or faults detected in its operation.

Several Realtime logs can be generated during operation of the datalogger.

These diagnostic features can be enabled and used by the ‘Maint’ user.

Left click on diagnostic menu option ‘Datalogger Maintenance’ to the datalogger configuration and diagnostic features as shown in figure 7.9 below.

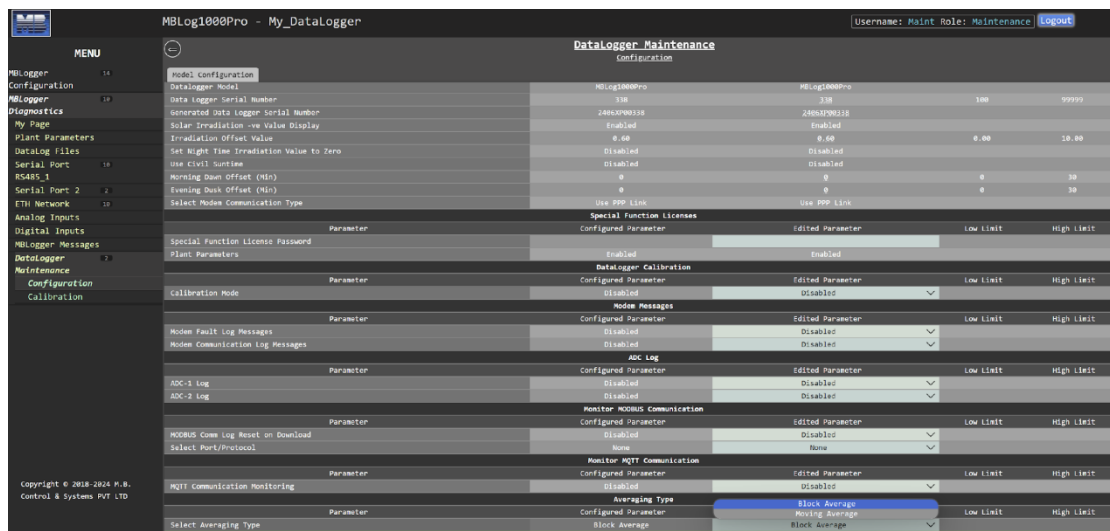

Figure-7.9: Datalogger maintenance configuration and diagnostics

Details of MLogger diagnostics feature configuration are provided in table 7.9 below. All the logs generated can be downloaded by the ‘Maint’ user.

Sr. No	Feature	Operation	Remarks
<b>Datalogger Operation</b>			
1	Special Function License	‘Enable’ or ‘Disable’	Special functions in the datalogger can be enabled or disabled.
2	Datalogger Calibration	‘Enable’ or ‘Disable’	Enables calibration of datalogger analog channels
<b>Modem Operation</b>			
1	Modem Fault Log Messages	‘Enable’ or ‘Disable’	‘Enable’ or ‘Disable’ internal modem error messages
2	Modem Communication Log Messages	‘Enable’ or ‘Disable’	‘Enable’ or ‘Disable’ internal modem communication messages. This log helps in analysing modem operation.
<b>Datalogger ADC Operation</b>			
1	ADC 1 Log ADC 2 Log	‘Enable’ or ‘Disable’	‘Enable’ or ‘Disable’ datalogger ADC operation logs. This log helps in analysing any errors in operation of ADC’s.

<b>Monitor IED Communication</b>			
1	Comm Log Reset on Download	'Enable' or 'Disable'	If enabled communication log will be reset when it is downloaded.
2	Select Port/ Protocol	Select communication port and protocol for logging from the dropdown list.	IED communication from the selected port and protocol shall be logged. This log is very useful tool for analysing communication problems with IED's and sensors connected to datalogger serial and IP ports.
<b>Monitor MQTT Communication</b>			
1	MQTT Communication Monitoring	'Enable' or 'Disable'	MQTT communication with 'Broker' can be logged when enabled. This can used to monitor communication with remote 'Broker'.
<b>Averaging Type</b>			
1	Select Averaging Type	Select between 'Block Average' and 'Moving Average'	'Block Average': Parameter average is calculated for the configured block time. 'Moving Average': Parameter average is calculated based on configured moving block time. The block time is moved at each parameter sample time.

Table-7.9: MBLLogger diagnostic features

## 7.10 Datalogger Diagnostic Logs

All the diagnostics logs generated by the data logger can be downloaded by the 'Maint' user.

Right click on diagnostic menu option 'MBLogger Messages' to see the list of logs available to download as shown in figure 7.10 below. Only enabled logs will be available to download.

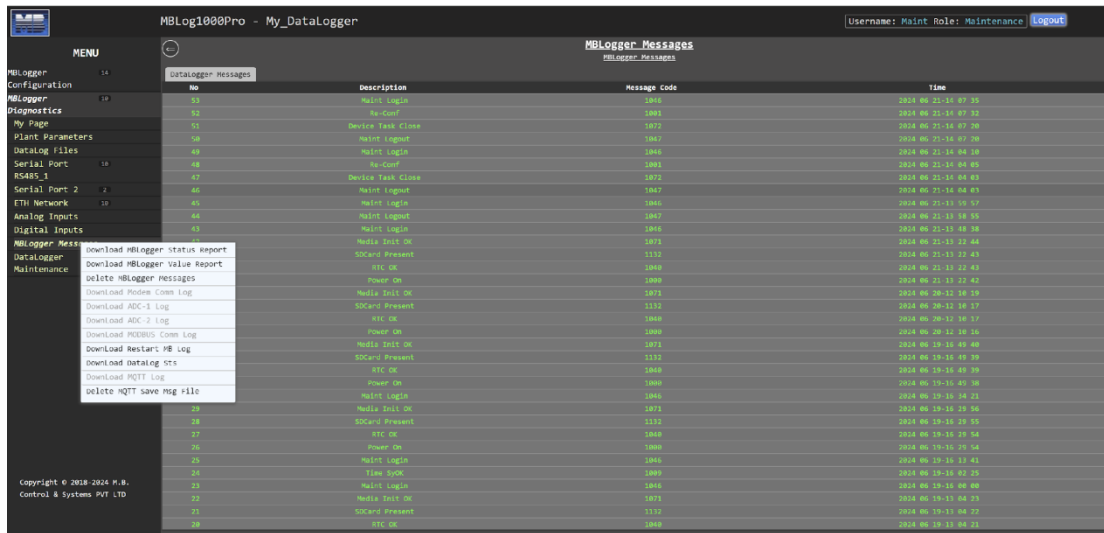

Figure-7.10: Datalogger diagnostic logs

Select the log to download. The log will be saved on the PC.

Following operation are possible:

- i) Download MBLogger Status Report
- ii) Download MBLogger Value Report
- iii) Delete MBLogger Message
- iv) Download Modem Comm Log
- v) Download ADC1 Log
- vi) Download ADC2 Log
- vii) Download MODBUS Comm Log
- viii) Download Restart MB Log
- ix) Download DatalogSts
- x) Download MQTT Log
- xi) Delete MQTT Save Msg File

Click on the option required.

### 7.10.1 Download MBLogger Status Report

Click on this option to download the status of datalogger and connected IED in .txt file. It will also download logged messages.

Downloaded file will have following information:

- i) Date and time of report
- ii) Model and serial number details.
- iii) Details of special function licenses installed in the datalogger.
- iv) Status of services on the datalogger.
- v) Status of all IED and sensors connected on various communication ports of the datalogger.
- vi) Details of sensors and sensors connected to analog inputs (not available for Nano model).
- vii) List of all the messages logged.

### 7.10.2 Download MBLogger Value Report

Click on this option to download values of all parameters from all inputs and connected IED in .txt file.

Downloaded file will have following information:

- i) Model and serial number details.
- ii) Values from all analog inputs (not available for Nano model).
- iii) Values from all digital inputs (not available for Nano model).
- iv) Values from all sensors and IED connected to serial and ETH ports of the datalogger.

Following information is provided in this report:

- i) Date and time of report
- ii) Description of sensors and IED connected to analog, digital and communication ports.
- iii) **'Qual'**: quality of parameter value. Good quality values will be marked as 'GD'. Bad quality values will be marked as 'IV'.
- iv) **'Value'**: parameter value in float format.
- v) **'Value\_Min'**: minimum value of the parameter for the block time.
- vi) **'Value\_Man'**: maximum value of the parameter for the block time.
- vii) **'Value\_Avg'**: average value of the parameter for the block time.
- viii) **'Value\_SD'**: Standard deviation for the parameter. It will be displayed only if the same is enabled in parameter configuration.
- ix) **'Value\_Int'**: Integrated value for the parameter. It will be displayed only if integration is enabled in parameter configuration.
- x) For digital inputs configured as status input, its state and state change time will be displayed.
- xi) **'MODBUS ID' or 'IP Address'**: shall be provided for communicable sensors and IED.
- xii) **'Comm Status'**: communication status shall be provided for communicable sensors and IED.
- xiii) List of parameters along with register addresses shall be provided for communication sensors and IED.

#### 7.10.3 Delete MBLogger Messages

This option is not available to users on the site. This operation deletes the datalogger operation messages.

#### 7.10.4 Download Modem Comm Log

Download modem communication log.

#### 7.10.5 Download ADC1 or ADC2 Logs

Download ADC operation logs.

#### 7.10.6 Download MODBUS Comm log

Download communication log with IED's and sensors via serial and ETH ports.

#### 7.10.7 Download Restart MB Log

MB data logger can save MODBUS communication log before the data logger was restarted. This communication log can be downloaded..

#### 7.10.8 Download DataLogSts

Download data log operation status and log.

#### 7.10.9 Download MQTT Log

Download MQTT IOT communication log.

#### 7.10.10 Delete MQTT Save Msg File

Delete saved MQTT IOT communication log file.

## 7.11 Datalogger Remote Diagnostics

MB Datalogger provides extensive features for remote diagnostics. All the datalogger diagnostics log files can be downloaded remotely. Datalogger operation commands can also be given remotely. Subscription to MBCloud SCADA is required to avail features of remote diagnostics.

## 8. MLogger Messages

MLogger provides messages for the following events:

- i) User login and logout
- ii) Datalogger re-configuration
- iii) Hardware faults

Details of message types are provided in table-8.1 below.

Sr. No	Message Type	Remarks	Action Required
1	Information	Information message. No effect on operation of the datalogger.	None
2	Fault	Hardware fault. Operation of the datalogger will be affected. Red Led 'ER' on front panel will flash.	Contact <a href="mailto:service@mbcontrol.com">service@mbcontrol.com</a>

Table-8: Datalogger message types

### 8.1 MLogger Information Messages

MLogger operation information messages are listed in table-8.1 below.

Sr. No	Code	Message	Message Type	Remarks
1	1000	Power On	Information	
2	1001	Re-Conf	Information	Datalogger has been re-configured
3	1002	Adm Login	Information	Administrator login and logout
4	1003	Adm Logout	Information	
5	1004	Opr Login	Information	Operator login and logout
6	1005	Opr Logout	Information	
7	1006	Viw Login	Information	Viewer login and logout
8	1007	Viw Logout	Information	
9	1008	Login Fail	Information	Invalid login attempt
10	1010	Time SyOK	Information	Time synchronisation OK after fail
11	1011	Time SyFail	Information	Time synchronisations fail
12	1012	DL Msg Deleted	Information	Data logger messages have been deleted.
13	1013	OLED Error	Information	OLED Error
14	1014	RFT1 Comm Media Fail	Information	Communication media for remote file transfer -1 has failed
15	1015	RFT1 Comm Media OK	Information	Communication media for remote file transfer -1 is OK
16	1016	RFT1 Connect ETH Fail	Information	Connection to remote file server -1 has failed via ETH port
17	1017	RFT1 Connect ETH OK	Information	Connection to remote file server -1 is OK via ETH port

18	1018	RFT1 File Write Fail	Information	File write operation for remote file server -1 has failed
19	1019	RFT1 File Write OK	Information	File write operation for remote file server -1 is OK
20	1020	RFT1 File Open Fail	Information	File open operation for remote file server -1 has failed
21	1021	RFT1 File Open OK	Information	File open operation for remote file server -1 is OK
22	1022	RFT1 File Close Fail	Information	File close operation for remote file server -1 has failed
23	1023	RFT1 File Close OK	Information	File close operation for remote file server -1 is OK
24	1024	RFT1 File Transmit Fail	Information	File transmit operation for remote file server -1 has failed
25	1025	RFT1 File Transmit OK	Information	File transmit operation for remote file server -1 is OK
26	1026	RFT2 Comm Media Fail	Information	Communication media for remote file transfer -2 has failed
27	1027	RFT2 Comm Media OK	Information	Communication media for remote file transfer -2 is OK
28	1028	RFT2 Connect ETH Fail	Information	Connection to remote file server -2 has failed via ETH port
29	1029	RFT2 Connect ETH OK	Information	Connection to remote file server -2 is OK via ETH port
30	1030	RFT2 File Write Fail	Information	File write operation for remote file server -2 has failed
31	1031	RFT2 File Write OK	Information	File write operation for remote file server -2 is OK
32	1032	RFT2 File Open Fail	Information	File open operation for remote file server -2 has failed
33	1033	RFT2 File Open OK	Information	File open operation for remote file server -2 is OK
34	1034	RFT2 File Close Fail	Information	File close operation for remote file server -2 has failed
35	1035	RFT21 File Close OK	Information	File close operation for remote file server -2 is OK
36	1036	RFT2 File Transmit Fail	Information	File transmit operation for remote file server -2 has failed
37	1037	RFT2 File Transmit OK	Information	File transmit operation for remote file server -2 is OK
38	1038	Modem PPP Link Up	Information	Modem PP Link is OK
39	1039	Modem PPP Link Down	Information	Modem PP Link has failed. All communication via modem will be stopped.
40	1040	RTC OK	Information	RTC is operating OK
41	1041	Modem File Transfer ETH	Information	File is being transmitted via ETH port instead of Modem.

				This can happen if the modem has failed and file transfer via ETH port is possible.
42	1042	Modem File Transfer Modem	Information	File transmission via Modem has been restored.
43	1042	Modem File Transfer Modem	Information	File transmission via Modem has been restored.
44	1043	Modem Fail Recovery	Information	Modem failure has been recovered
45	1044	ETH Port Not Connected	Information	ETH port is not connected to any network
46	1045	ETH Port Connected	Information	ETH port is connected to network
47	1046	Maint Login	Information	Maintenance user login and logout
48	1047	Maint Logout	Information	
49	1048	Calibration Mode Start	Information	Datalogger is in calibration mode
50	1049	Calibration Mode End	Information	Datalogger is in normal mode of operation
51	1050	Datalogger Restart	Information	Datalogger has re-started itself.
52	1051	Task Termination Fail	Information	System message for tasks operation
53	1052	Messages Deleted	Information	Logged messages have been deleted.
54	1053	RFT1 Connect Modem Fail	Information	Connection to remote file server -1 has failed via Modem
55	1054	RFT1 Connect Modem OK	Information	Connection to remote file server -1 is OK via Modem
56	1055	RFT2 Connect Modem Fail	Information	Connection to remote file server -2 has failed via Modem
57	1056	RFT2 Connect Modem OK	Information	Connection to remote file server -2 is OK via Modem
58	1057	SNTP Media Change Modem	Information	SNTP client media has been changed from ETH to Modem. This will happen if SNTP client fails to connect to time server via ETH network and modem is working OK.
59	1058	SNTP Media Change ETH	Information	SNTP client media has been changed from Modem to ETH. This will happen if SNTP client fails to connect to time server via modem and ETH network is working OK.
60	1059	ADC-2 ReInit OK	Information	ADC-2 has been re-initialised
61	1060	Serial Port1 Re Conf	Information	Serial port port-1 has been re-configured

62	1061	Serial Port2 Re Conf	Information	Serial port port-2 has been re-configured
62	1062	ADC-1 Fail	Information	ADC-1 operation failed
63	1063	ADC-1 Ch Value Error	Information	Error in ADC-1 channel value
64	1064	ADC-1 Reg Error	Information	ADC-1 register read error
65	1065	ADC-1 ReInit OK	Information	ADC-1 re-initialisation is OK
66	1066	DayLog File Write fail	Information	Error in writing to data log file
67	1967	RFT1Log File Write Fail	Information	Error in writing to remote file server-1 data log file
68	1068	RFT2Log File Write Fail	Information	Error in writing to remote file server-2 data log file
69	1069	Config File Write Fail	Information	Error in writing to device configuration file
70	1070	File Write size mismatch	Information	Mismatch in size of file being written
71	1071	MMC Media Init OK	Information	MMC media (SD Card) interface initialisation is OK
72	1072	Device Task Close	Information	All tasks in the device have been closed
73	1073	RFT1 Disconnect Modem Fail	Information	Disconnection with RFT server-1 via modem has failed.
74	1074	RFT1 Disconnect Modem OK	Information	Disconnection with RFT server-1 via modem is successful.
75	1075	RFT2 Disconnect Modem Fail	Information	Disconnection with RFT server-2 via modem has failed.
76	1076	RFT2 Disconnect Modem OK	Information	Disconnection with RFT server-2 via modem is successful.
77	1077	RFT1 Disconnect ETH Fail	Information	Disconnection with RFT server-1 via ETH has failed.
78	1078	RFT1 Disconnect ETH OK	Information	Disconnection with RFT server-1 via ETH is successful.
79	1079	RFT2 Disconnect ETH Fail	Information	Disconnection with RFT server-2 via ETH has failed.
80	1080	RFT2 Disconnect ETH OK	Information	Disconnection with RFT server-2 via ETH is successful.
81	1081	Modem Registered	Information	Modem Registration is OK
82	1082	Modem Registration Failed	Information	Modem Registration Failed
83	1083	Cellular Signal Low	Information	Cellular signal strength is low. Relocate the antenna to get required signal strength
84	1084	Cellular Signal Ok	Information	Cellular signal strength is ok.

85	1093	MB Slave Socket Not Free	Information	No more sockets are available for MODBUS Slave client. Number of MODBUS clients have exceeded the allowed limit. Disconnect one MODBUS Slave client and try again.
86	1094	GPS Connected	Information	GPS is connected to satellites
87	1095	GPS Fail	Information	GPS is not able to connect to satellites
88	1096	GPS Not Connected	Information	GPS is not connected to satellites
89	1097	Device IP set to Default	Information	Device IP was set to default manually
90	1098	PPP Link Restore Command	Information	Command has been issued for re-storing the PPP link
91	1099	PPP Link Restore Comd Fail	Information	PPP link restore command has failed
92	1100	RTC Open Fail	Information	RTC device open has failed
93	1101	RTC Start Fail	Information	RTC device has failed to start
94	1102	Modem FTP Stop Fail	Information	Modem FTP stop command has failed
95	1103	Modem FTP Change Directory Fail	Information	Modem FTP change directory command has failed
96	1104	Modem FTP CD fail	Information	Modem FTP CD command has failed
97	1105	Modem FTP Del fail	Information	Modem FTP Delete File command has failed
98	1106	Modem FTP Logout fail	Information	Modem FTP Logout command has failed
99	1107	Modem FTP Abort fail	Information	Modem FTP Abort command has failed
100	1108	Modem Com Restore Fail	Information	Modem communication restore has failed
101	1109	Modem FTP Stop OK	Information	Modem FTP Stop command is OK
102	1110	Modem FTP Start OK	Information	Modem FTP Start command is OK
103	1111	Modem FTP Abort OK	Information	Modem FTP Abort command is OK
104	1112	FTP StFail Log Stop	Information	Modem communication message has been stopped due Modem Stop Command Fail
105	1113	Modem FTP Login Fail	Information	Modem FTP Login failed
106	1114	Modem Message Log Enabled	Information	Modem Message Log in enabled

107	1115	Modem Message Log Disabled	Information	Modem Message Log in disabled
108	1116	Modem Restart Success	Information	Modem Restart is successful
109	1117	Modem Reset Fail	Information	Modem Reset has failed
110	1118	Modem SIM Present	Information	SIM is present in the modem
111	1119	Modem SIM Not Present	Information	SIM is Not present in the modem. It will not be possible to use the modem for data communication.
112	1120	Sun Present	Information	Information on sun presence
113	1121	Sun Not present	Information	
114	1122	Device Restarted	Information	
115	1123	Day Log directory Full	Information	<u>Delete</u> files in the directory to continue logging.
116	1124	RFT-1 Log directory Full	Information	<u>Delete</u> files in the directory to continue logging
117	1125	RFT-2 Log directory Full	Information	<u>Delete</u> files in the directory to continue logging
118	1126	Config directory full	Information	Delete files in the directory
119	1127	MBSlave Pool Reset OK	Information	
120	1128	MBSlave Pool Deplete	Information	IP Pool for MBSlave is full. Contact MBCS service. <a href="mailto:service@mbcontrol.com">mailto:service@mbcontrol.com</a> ☎:service@mbcontrol.com
121	1129	MBSlave Pool Alloc Fail	Information	Contact MBCS service.
122	1130	Modem Reg Home Network	Information	Modem is registered in home network
123	1131	Modem Reg Roaming Network	Information	Modem is registered in roaming network
124	1132	IPO Pool Depleted	Information	Contact MBCS service
125	1133	Modem Reg Denied	Information	Modem registration is denied by the service provider. Check SIM plan or service provider.
126	1134	eMMC Present	Information	
127	1135	Media Format Fail	Information	Media format has failed. Change the media SDCard.
128	1136	Media Format OK	Information	
129	1137	Media Format Start	Information	
130	1138	Media Format required	Information	Format the media
131	1139	SD Card Present	Information	

132	1140	SD Card Not Present	Information	Data logging will be disabled.
133	1141	IP Pool Reset	Information	
134	1142	IP InvListner	Information	
135	1143	Media Restore	Information	Media has been restored
136	1144	RFT1 Server Space Full	Information	RFT -1 destination server has no more space for files
137	1145	RFT1 Server Space Available	Information	
138	1146	RFT2 Server Space Full	Information	RFT -2 destination server has no more space for files
139	1147	RFT2 Server Space Available	Information	
140	1148	Invalid Day Log File name	Information	
141	1149	Invalid RFT-1 File name	Information	
142	1150	Invalid RFT-2 File name	Information	
143	1151	Day File Corrupt	Information	
144	1152	RFT-1 File Corrupt	Information	
145	1153	RFT-2 File Corrupt	Information	
146	1154	MBSlave Comm Stopped	Information	
147	1155	IOT Connect Fail	Information	Check IOT Broker credentials or internet connection
148	1156	IOT Connect OK	Information	
149	1157	MQTT StFail Log Stop	Information	
150	1158	MQTT Start Fail	Information	
151	1159	MQTT Start Ok	Information	
152	1160	MQTT Stop Fail	Information	
153	1161	MQTT Stop OK	Information	
154	1162	MQTT Connect Fail	Information	
155	1163	MQTT Connect OK	Information	
156	1164	MQTT Fail	Information	
157	1165	MQTT OK	Information	
158	1166	MQTT Auth Fail	Information	IOT Authorisation has failed. Check MQTT publisher credentials.
159	1167	PPP Google Restore	Information	
160	1168	Sensor Cal Const Input	Information	Sensor calibration constants have been input manually

161	1169	File Create Error	Information	
162	1170	DayLog Open Fail	Information	
163	1171	RFT1 Log Open Fail	Information	
164	1172	RFT2 Log Open Fail	Information	
165	1173	RFT1 File Create Fail	Information	
166	1174	RFT2 File Create Fail	Information	

Table-8.1: Datalogger operation information messages

## 8.2 MBLLogger Fault Messages

MBLogger operation fault messages are listed in table-8.2 below.

Sr. No	Code	Message	Message Type	Remarks
1	2000	QSPI Fail	Fault	Internal non-volatile memory fail. Datalogger will not function.
2	2001	SDRAM Fail	Fault	Internal memory fail. Datalogger will not function.
3	2002	ADC-1 Fail	Fault	Analog input channels – Voltage inputs and mA input will not operate.
4	2003	ADC-2 Fail	Fault	Analog input channels –mV input will not operate.
5	2004	Modem Fail	Fault	Internal modem will not function. This will affect functions working via modem.
6	2005	Key Operation Fail	Fault	Will affect key operation
7	2006	RTC Fail	Fault	RTC operation has failed. It will affect all time-based operations
8	2007	RTCbackup Fail	Fault	RTC time was not backed up. Change the RTC backup battery
9	2008	ADC-1 SPI initialisation Fail	Fault	Fault in ADC-1
10	2009	ADC-1 Reset Fail	Fault	Fault in ADC-1
11	2010	ADC-1 ID read Fail	Fault	Fault in ADC-1
12	2011	ADC-1 read Reg Fail	Fault	Fault in ADC-1

13	2012	ADC-2 SPI initialisation Fail	Fault	Fault in ADC-2
14	2013	ADC-2 Reset Fail	Fault	Fault in ADC-1
15	2014	ADC-2 ID read Fail	Fault	Fault in ADC-1
16	2015	ADC-2 read Reg Fail	Fault	Fault in ADC-1
17	2016	ADC-2 Calibration Fail	Fault	Fault in ADC-1
18	2017	ADC-2 Channel Sel Fail	Information	Fault in ADC-2 channel selection
19	2018	ADC-2 ReInit Fail	Fault	Fault in ADC-2 re-initialisation
20	2019	ADC-2 Ref Volt Err	Information	Fault in ADC-2.
21	2020	ADC-2 Error	Information	Error in ADC-2 reference voltage
22	2021	ADC-2 Parity Error	Information	Fault in reading ADC-2
23	2022	Data Flash Fail	Fault	Fault in controller data flash memory
24	2023	Serial Port 1 Fail	Fault	Fault in datalogger serial port- 1
25	2024	Serial Port 2 Fail	Fault	Fault in datalogger serial port- 2
26	2025	ADC-1 ReInit Fail	Fault	Re-initialisation of ADC-1 failed
27	2026	ADC-1 Calibration Fail	Fault	Re-calibration of ADC-1 failed
28	2027	MMC Media Init Fail	Fault	MMC media (SD Card) interface initialisation has failed. SD card will not function properly.
29	2028	ADC-1 Alarm	Fault	ADC-1 has failed
30	2029	MMC Media Fail	Fault	MMC media (SD Card) has failed.
31	2030	Device IP Fail	Fault	Contact MBCS service
32	2031	FAT Read Error	Fault	Reformat the media

Table-8.2: Datalogger operation fault messages

## 9. Technical Specifications

### 9.1 General Specifications

Sr. No	Parameter	Specification
1	Micro-Processor	32 bits ARM Processor
2	RTC	Temperature compensated. RTC

Table-9.1: Datalogger general specifications

### 9.2 Analog Inputs

Sr. No	Parameter	Specification
1	Input 4-20mA	4
2	Input V (0-10V)	4
3	Input mV (0-1V)	4 Resolution 1 $\mu$ V
4	Battery Voltage	1
5	ADC Resolution	2 X 24 bits
6	Sampling Rate	10Hz
7	Accuracy	0.1%
8	Noise filter	Notch at 50Hz and 60Hz
9	Statistical Calculations (configurable)	Average, Minimum, Maximum, Standard Deviation, and Integration

Table-9.2: MBLogger Analog Inputs

### 9.3 Digital Inputs

Sr. No	Parameter	Specification
1	Digital Inputs	4
2	Isolation	Optical
3	External Power supply	Not required. Internally powered.
4	Input Signal	Potential free or Open collector
5	Maximum Input Pulse Rate	<100Hz
6	Calculations	Totalisation, Windspeed, Rain calculation etc.

Table-9.3: MBLogger Digital Inputs

### 9.4 Status LED

Sr. No	Parameter	Marking	Remarks
1	Digital Inputs	D1, D2, D3 and D4	Green LED on front panel. Operation based on 'Power Save Mode' configuration
2	Health	HLT	Green LED –Flashing on front panel.
3	Error	ER	Red LED –Flashing on front panel if any fault is detected or logged.

Table-9.4: MBLogger status LED

## 9.5 Colour OLED and Keypad

Sr. No	Parameter	Specification
1	OLED Display	Graphic colour- 160x120 pixels
2	Keypad	Five button capacity keys.

Table-9.5: OLED and keys

## 9.6 Communication Serial Port-1 (RS485)

Sr. No	Parameter	Specification
1	Baud rate	4,800, 9,600 and 19,200 bps
2	Isolation	2.5KV
3	Protocols	MODBUS RTU Master MODBUS RTU Slave
4	Maximum number of sensor/ IED that can be connected	10 (i)

Table-9.6: Serial Port-1 (RS485)

## 9.7 Communication Serial Port-2 (RS232 or RS485)

### 9.7.1 Communication Serial Port-2 (RS485):

Sr. No	Parameter	Specification
1	Baud rate	4800, 9600 and 19200 bps
2	Isolation	2.5KV
3	Protocols	MODBUS RTU Master MODBUS RTU Slave
4	Maximum number of sensor/ IED that can be connected	10 (i)

Table-9.7.1: Serial Port-2 (RS485)

### 9.7.2 Communication Serial Port-2 (RS232):

Sr. No	Parameter	Specification
1	Baud rate	1200, 4800, 9600 and 19200 bps
2	Isolation	1.5KV
3	Protocols	MODBUS RTU Master MODBUS RTU Slave ASCII Master ASCII Slave
4	Maximum number of sensor/ IED that can be connected	1 (iii)

Table-9.7.2: Serial Port-2 (RS232)

## 9.8 Communication Port ETH

Sr. No	Parameter	Specification
1	Speed	100MHz
2	Protocols	MODBUS TCP Master MODBUS TCP Slave SNTP client, FTP, HTTP, Embedded web server
3	Maximum number of sensor/ IED that can be connected	10 (i)

Table-9.8: Port ETH

Note:

- i) Maximum number of parameters for each sensor/ IED is limited to 25.
- ii) Total number of parameters for all sensors / IED's cannot exceed 600.
- iii) Maximum number of parameters for ASCII IED is 12. Only one IED/ sensor can be interfaced to RS232 port.
- iv) Maximum number of parameters that can be integrated is 200.

## 9.9 Internal Modem

Sr. No	Parameter	Specification
1	Modem Type	Quad band 4G (CAT-1) modem with antenna.
2	Frequency band	TDD LTE: B40/B41 GSM: 900/1800Mhz

Table-9.9: Internal Modem

## 9.10 Datalogging

Sr. No	Parameter	Specification
1	Datalogging time (periodical time)	Site configurable
2	SD Card	Up-to 16GB (FAT32)
3	Protocol	FTP via ETH port or inbuilt Modem

Table-9.10: Datalogging operation

## 9.11 Electrical

Sr. No	Parameter	Specification
1	Power supply voltage input	9-32 VDC
2	Power Consumption	With cellular modem: 4.1 W at 12VDC
		Without cellular modem: 2.75 W at 12 VDC

Table-9.11: Electrical specifications

## 9.12 Environmental

Sr. No	Parameter	Specification
1	Operating Temperature range	-40°C to +70°C
2	Storage Temperature	-50°C to +80°C
3	Operating Humidity	Maximum 95% - noncondensing

Table-9.12: Environmental specifications

## 9.13 Physical

Sr. No	Parameter	Specification
1	Protection	IP20
2	Dimensions (W x H x L)	90 x 62 x 162 mm
3	Weight	0.5 Kg (approx....)
4	Mounting	DIN Rail
5	Housing material	Polycarbonate

Table-9.13: Physical specifications

## 9.14 Add ON- Module (High Speed Digital Inputs)

Sr. No	Parameter	Specification
1	Model	MBLogger100-12P
2	Digital inputs	12
3	Isolation	Optical
4	Input Signal	Potential free or Open collector
5	Maximum Input Pulse Rate	<1 K Hz
6	Calculations	Totalisation, Windspeed, Rain calculation etc.
7	Sensor power supply output	12VDC / 150mA
8	Module Power supply	9-32 VDC
9	Power Consumption	2.5W

Table-9.14: Add-On Module MBLogger1000 – 12P

## 10. MLogger MODBUS Slave Registers

All parameters measured and read from sensors and IED are available via MODBUS slave registers.

Details of these registers are provided in this section.

Note: Standard deviation value and Integrated values shall be provided if these are configured for the parameter.

### 10.1 Data Logger Time

Sr. No	Parameter	Register Address	Type	Read/ Write
1	Data logger epoch second	10	32 bits un-signed integer	Read/ Write

Table-10.1: Datalogger RTC time

Note: For writing time to datalogger – 32 bits should be written with write command.

### 10.2 My Page Parameters

Sr. No	Parameter	Attribute	Register Address	Type	Read/ Write
1	My Parameter-1	Value	20	32 bits float	Read only
2	My Parameter-2	Value	22	32 bits float	Read only
3	My Parameter-3	Value	24	32 bits float	Read only
4	My Parameter-4	Value	26	32 bits float	Read only
5	My Parameter-5	Value	28	32 bits float	Read only
6	My Parameter-6	Value	30	32 bits float	Read only
7	My Parameter-7	Value	32	32 bits float	Read only
8	My Parameter-8	Value	34	32 bits float	Read only
9	My Parameter-9	Value	36	32 bits float	Read only
10	My Parameter-10	Value	38	32 bits float	Read only
11	My Parameter-11	Value	40	32 bits float	Read only
12	My Parameter-12	Value	42	32 bits float	Read only
13	My Parameter-13	Value	44	32 bits float	Read only
14	My Parameter-14	Value	46	32 bits float	Read only
15	My Parameter-15	Value	48	32 bits float	Read only
16	My Parameter-16	Value	50	32 bits float	Read only
17	My Parameter-17	Value	52	32 bits float	Read only
18	My Parameter-18	Value	54	32 bits float	Read only
19	My Parameter-19	Value	56	32 bits float	Read only
20	My Parameter-20	Value	58	32 bits float	Read only
21	My Parameter-21	Value	60	32 bits float	Read only
22	My Parameter-22	Value	62	32 bits float	Read only
23	My Parameter-23	Value	64	32 bits float	Read only
24	My Parameter-24	Value	66	32 bits float	Read only
25	My Parameter-25	Value	68	32 bits float	Read only
26	My Parameter-26	Value	70	32 bits float	Read only

27	My Parameter-27	Value	72	32 bits float	Read only
28	My Parameter-28	Value	74	32 bits float	Read only
29	My Parameter-29	Value	78	32 bits float	Read only
30	My Parameter-30	Value	80	32 bits float	Read only
31	My Parameter-31	Value	82	32 bits float	Read only
32	My Parameter-32	Value	84	32 bits float	Read only
33	My Parameter-33	Value	86	32 bits float	Read only
34	My Parameter-34	Value	88	32 bits float	Read only
35	My Parameter-35	Value	90	32 bits float	Read only
36	My Parameter-36	Value	92	32 bits float	Read only

Table-10.2: My Page Parameters

**Note:** My Page parameters shall be updated each 500 msec.

### 10.3 Analog Inputs (mA)

Sr. No	Parameter	Attribute	Register Address	Type	Read/ Write
1	Analog input mA1	Value	200	32 bits float	Read only
2		Value-minimum	202	32 bits float	Read only
3		Value-maximum	204	32 bits float	Read only
4		Value- average	206	32 bits float	Read only
5		Value-Standard Deviation	208	32 bits float	Read only
6		Value-Integrated	210	32 bits float	Read only
7	Analog input mA2	Value	212	32 bits float	Read only
8	Analog input mA3	Value	224	32 bits float	Read only
9	Analog input mA4	Value	236	32 bits float	Read only

Table-10.3: Analog Inputs (mA)

### 10.4 Analog Inputs (mV)

Sr. No	Parameter	Attribute	Register Address	Type	Read/ Write
1	Analog input mV 1	Value	248	32 bits float	Read only
2		Value-minimum	250	32 bits float	Read only
3		Value-maximum	252	32 bits float	Read only
4		Value-average	254	32 bits float	Read only

5		Value-Standard Deviation	256	32 bits float	Read only
6		Value-Integrated	258	32 bits float	Read only
7	Analog input mV2	Value	260	32 bits float	Read only
8	Analog input mV3	Value	272	32 bits float	Read only
9	Analog input mV4	Value	284	32 bits float	Read only

Table-10.4: Analog Inputs (mV)

## 10.5 Analog Inputs (V)

Sr. No	Parameter	Attribute	Register Address	Type	Read/ Write
1	Analog input V -1	Value	296	32 bits float	Read only
2		Value-minimum	298	32 bits float	Read only
3		Value-maximum	300	32 bits float	Read only
4		Value- average	302	32 bits float	Read only
5		Value-Standard Deviation	304	32 bits float	Read only
6		Value-Integrated	306	32 bits float	Read only
7	Analog input V-2	Value	308	32 bits float	Read only
8	Analog input V-3	Value	320	32 bits float	Read only
9	Analog input V-4	Value	332	32 bits float	Read only

Table-10.5: Analog Inputs (V)

## 10.6 Battery Voltage Input

Sr. No	Parameter	Attribute	Register Address	Type	Read/ Write
1	Battery voltage input	Value	344	32 bits float	Read only
2		Value-minimum	346	32 bits float	Read only
3		Value-maximum	348	32 bits float	Read only
4		Value- average	350	32 bits float	Read only

Table-10.6: Battery Voltage Input

## 10.7 Digital Inputs

### 10.7.1 Digital Input – Status

Register details for digital input used for status input monitoring.

Sr. No	Parameter	Attribute	Register Address	Type	Read/ Write
1	Digital input 1	Status	400	32 bits float	Read only
2		State change epoch second	402	32 bits float	Read only
3	Digital input 2	Status	412	32 bits float	Read only
4		State change epoch second	414	32 bits float	Read only
5	Digital input 3	Status	424	32 bits float	Read only
6		State change epoch second	426	32 bits float	Read only
7	Digital input 4	Status	436	32 bits float	Read only
8		State change epoch second	438	32 bits float	Read only

Table-10.7.1: Digital inputs – status

### 10.7.2 Digital Input- Rain Gauge

Register details for digital input used for rain gauge monitoring.

Sr. No	Parameter	Attribute	Register Address	Type	Read/ Write
1	Digital input 1	Accumulated Value	400	32 bits float	Read only
2	Digital input 2	Accumulated Value	412	32 bits float	Read only
3	Digital input 3	Accumulated Value	424	32 bits float	Read only
4	Digital input 4	Accumulated Value	436	32 bits float	Read only

Table-10.7.2: Digital inputs – Rain Gauge

### 10.7.3 Digital Input – Wind speed

Register details for digital input used for wind speed monitoring.

Sr. No	Parameter	Value	Register Address	Type	Read/ Write
1	Digital input 1	Value	400	32 bits float	Read only
2		Value-minimum	404	32 bits float	Read only

3		Value-maximum	406	32 bits float	Read only
4		Value-average	408	32 bits float	Read only
5		Value-Standard Deviation	410	32 bits float	Read only
6	Digital input 2: Wind speed	Value	412	32 bits float	Read only
7	Digital input 3: Wind speed	Value	424	32 bits float	Read only
8	Digital input 4: Wind speed	Value	436	32 bits float	Read only

Table-10.7.3: Digital inputs – wind speed monitoring

## 10.8 Sensors and IED Connected to Serial and ETH Ports

### 10.8.1 Serial Port RS485-1

Register details for sensors and IED connected to serial port RS485-1.

Sr. No	Sensor/ IED	Parameter	Attribute	Register Address	Type	Read/ Write
1	IED-1	Parameter -1	Value	500	32 bits float	Read only
2			Value-minimum	502	32 bits float	Read only
3			Value-maximum	504	32 bits float	Read only
4			Value-average	506	32 bits float	Read only
5			Value-Standard Deviation	508	32 bits float	Read only
6			Value-Integrated	510	32 bits float	Read only
7		Parameter -2	Value	512	32 bits float	Read only
8		Parameter -3	Value	524	32 bits float	Read only
9		Parameter -4	Value	536	32 bits float	Read only
10		Parameter -5	Value	548	32 bits float	Read only
11		Parameter -6	Value	560	32 bits float	Read only
12		Parameter -7	Value	572	32 bits float	Read only
13		Parameter -8	Value	584	32 bits float	Read only
13		Parameter -9	Value	596	32 bits float	Read only
15		Parameter -10	Value	608	32 bits float	Read only
16		Parameter -11	Value	620	32 bits float	Read only
17		Parameter -12	Value	632	32 bits float	Read only
18		Parameter -13	Value	644	32 bits float	Read only
19		Parameter -14	Value	656	32 bits float	Read only
20		Parameter -15	Value	668	32 bits float	Read only

21		Parameter -16	Value	680	32 bits float	Read only
22		Parameter -17	Value	692	32 bits float	Read only
23		Parameter -18	Value	704	32 bits float	Read only
24		Parameter -19	Value	716	32 bits float	Read only
25		Parameter -20	Value	728	32 bits float	Read only
26		Parameter -21	Value	740	32 bits float	Read only
27		Parameter -22	Value	752	32 bits float	Read only
28		Parameter -23	Value	764	32 bits float	Read only
29		Parameter -24	Value	776	32 bits float	Read only
30		Parameter -25	Value	788	32 bits float	Read only
31	IED-2	Parameter -1	Value	800	32 bits float	Read only
32	IED-3	Parameter -1	Value	1100	32 bits float	Read only
33	IED-4	Parameter -1	Value	1400	32 bits float	Read only
34	IED-5	Parameter -1	Value	1700	32 bits float	Read only
35	IED-6	Parameter -1	Value	2000	32 bits float	Read only
36	IED-7	Parameter -1	Value	2300	32 bits float	Read only
37	IED-8	Parameter -1	Value	2600	32 bits float	Read only
38	IED-9	Parameter -1	Value	2900	32 bits float	Read only
39	IED-10	Parameter -1	Value	3200	32 bits float	Read only
40	IED-11	Parameter -1	Value	3500	32 bits float	Read only
41	IED-12	Parameter -1	Value	3800	32 bits float	Read only
42	IED-13	Parameter -1	Value	4100	32 bits float	Read only
43	IED-14	Parameter -1	Value	4400	32 bits float	Read only
44	IED-15	Parameter -1	Value	4700	32 bits float	Read only

Table-10.8.1: Register details for sensors and IED connected to serial port RS485-1.

### 10.8.2 Serial Port RS485-2

Register details for sensors and IED connected to serial port RS485-2.

Sr. No	Sensor/ IED	Parameter	Attribute	Register Address	Type	Read/ Write
1	IED-1	Parameter -1	Value	3500	32 bits float	Read only
2			Value-minimum	3502	32 bits float	Read only
3			Value-maximum	3504	32 bits float	Read only
4			Value-average	3506	32 bits float	Read only
5			Value-Standard Deviation	3508	32 bits float	Read only
6			Value-Integrated	3510	32 bits float	Read only
7		Parameter -2	Value	3512	32 bits float	Read only
8		Parameter -3	Value	3524	32 bits float	Read only
9		Parameter -4	Value	3536	32 bits float	Read only
10		Parameter -5	Value	3548	32 bits float	Read only
11		Parameter -6	Value	3560	32 bits float	Read only

12		Parameter -7	Value	3572	32 bits float	Read only
13		Parameter -8	Value	3584	32 bits float	Read only
13		Parameter -9	Value	3596	32 bits float	Read only
15		Parameter -10	Value	3608	32 bits float	Read only
16		Parameter -11	Value	3620	32 bits float	Read only
17		Parameter -12	Value	3632	32 bits float	Read only
18		Parameter -13	Value	3644	32 bits float	Read only
19		Parameter -14	Value	3656	32 bits float	Read only
20		Parameter -15	Value	3668	32 bits float	Read only
21		Parameter -16	Value	3680	32 bits float	Read only
22		Parameter -17	Value	3692	32 bits float	Read only
23		Parameter -18	Value	3704	32 bits float	Read only
24		Parameter -19	Value	3716	32 bits float	Read only
25		Parameter -20	Value	3728	32 bits float	Read only
26		Parameter -21	Value	3740	32 bits float	Read only
27		Parameter -22	Value	3752	32 bits float	Read only
28		Parameter -23	Value	3764	32 bits float	Read only
29		Parameter -24	Value	3776	32 bits float	Read only
30		Parameter -25	Value	3788	32 bits float	Read only
31	IED-2	Parameter -1	Value	3800	32 bits float	Read only
32	IED-3	Parameter -1	Value	4100	32 bits float	Read only
33	IED-4	Parameter -1	Value	4400	32 bits float	Read only
34	IED-5	Parameter -1	Value	4700	32 bits float	Read only
35	IED-6	Parameter -1	Value	5000	32 bits float	Read only
36	IED-7	Parameter -1	Value	5300	32 bits float	Read only
37	IED-8	Parameter -1	Value	5600	32 bits float	Read only
38	IED-9	Parameter -1	Value	5900	32 bits float	Read only
39	IED-10	Parameter -1	Value	6200	32 bits float	Read only
40	IED-11	Parameter -1	Value	6500	32 bits float	Read only
41	IED-12	Parameter -1	Value	6800	32 bits float	Read only
42	IED-13	Parameter -1	Value	7100	32 bits float	Read only
43	IED-14	Parameter -1	Value	7400	32 bits float	Read only
44	IED-15	Parameter -1	Value	7700	32 bits float	Read only

Table-10.8.2: Register details for sensors and IED connected to serial port RS485-2.

### 10.8.3 Serial Port RS-232-2 – ASCII IED

Register details for sensors and IED connected to serial port RS-232-2 with ASCII (Master or Slave) protocol.

Sr. No	Sensor/ IED	Parameter	Attribute	Register Address	Type	Read/ Write
1	IED-1	Parameter -1	Value	6500	32 bits float	Read only
2			Value-minimum	6502	32 bits float	Read only
3			Value-maximum	6504	32 bits float	Read only
4			Value-average	6506	32 bits float	Read only

5			Value-Standard Deviation	6508	32 bits float	Read only
6			Value-Integrated	6510	32 bits float	Read only
7		Parameter -2	Value	6512	32 bits float	Read only
8		Parameter -3	Value	6524	32 bits float	Read only
9		Parameter -4	Value	6536	32 bits float	Read only
10		Parameter -5	Value	6548	32 bits float	Read only
11		Parameter -6	Value	6560	32 bits float	Read only
12		Parameter -7	Value	6572	32 bits float	Read only
13		Parameter -8	Value	6584	32 bits float	Read only
13		Parameter -9	Value	6596	32 bits float	Read only
15		Parameter -10	Value	6608	32 bits float	Read only
16		Parameter -11	Value	6620	32 bits float	Read only
17		Parameter -12	Value	6632	32 bits float	Read only

Table-10.8.3: Register details for sensors and IED connected to serial port RS232-2 with ASCII protocol.

#### 10.8.4 Serial Port RS-232-2 – MODBUS RTU IED

Register details for sensors and IED connected to serial port RS-232-2 with MODBUS RTU protocol.

Sr. No	Sensor/ IED	Parameter	Attribute	Register Address	Type	Read/ Write
1	IED-1	Parameter -1	Value	9800	32 bits float	Read only
2			Value-minimum	9802	32 bits float	Read only
3			Value-maximum	9804	32 bits float	Read only
4			Value-average	9806	32 bits float	Read only
5			Value-Standard Deviation	9808	32 bits float	Read only
6			Value-Integrated	9810	32 bits float	Read only
7			Parameter -2	Value	9812	32 bits float
8	Parameter -3	Value	9824	32 bits float	Read only	
9	Parameter -4	Value	9836	32 bits float	Read only	
10	Parameter -5	Value	9848	32 bits float	Read only	
11	Parameter -6	Value	9860	32 bits float	Read only	
12	Parameter -7	Value	9872	32 bits float	Read only	
13	Parameter -8	Value	9884	32 bits float	Read only	
13	Parameter -9	Value	9896	32 bits float	Read only	
15	Parameter -10	Value	9908	32 bits float	Read only	
16	Parameter -11	Value	9920	32 bits float	Read only	
17	Parameter -12	Value	9932	32 bits float	Read only	
18	Parameter -13	Value	9944	32 bits float	Read only	

19		Parameter -14	Value	9956	32 bits float	Read only
20		Parameter -15	Value	9968	32 bits float	Read only
21		Parameter -16	Value	9980	32 bits float	Read only
22		Parameter -17	Value	9992	32 bits float	Read only
23		Parameter -18	Value	10004	32 bits float	Read only
24		Parameter -19	Value	10016	32 bits float	Read only
25		Parameter -20	Value	10028	32 bits float	Read only
26		Parameter -21	Value	10040	32 bits float	Read only
27		Parameter -22	Value	10052	32 bits float	Read only
28		Parameter -23	Value	10064	32 bits float	Read only
29		Parameter -24	Value	10076	32 bits float	Read only
30		Parameter -25	Value	10088	32 bits float	Read only

Table-10.8.4: Register details for sensors and IED connected to serial port RS232-2 with MODBUS RTU protocol.

### 10.8.5 ETH Port

Register details for sensors and IED connected to serial port ETH.

Sr. No	Sensor/ IED	Parameter	Attribute	Register Address	Type	Read/ Write
1	IED-1	Parameter -1	Value	6800	32 bits float	Read only
2			Value-minimum	6802	32 bits float	Read only
3			Value-maximum	6804	32 bits float	Read only
4			Value-average	6806	32 bits float	Read only
5			Value-Standard Deviation	6808	32 bits float	Read only
6			Value-Integrated	6810	32 bits float	Read only
7			Parameter -2	Value	6812	32 bits float
8	Parameter -3	Value	6824	32 bits float	Read only	
9	Parameter -4	Value	6836	32 bits float	Read only	
10	Parameter -5	Value	6848	32 bits float	Read only	
11	Parameter -6	Value	6860	32 bits float	Read only	
12	Parameter -7	Value	6872	32 bits float	Read only	
13	Parameter -8	Value	6884	32 bits float	Read only	
13	Parameter -9	Value	6896	32 bits float	Read only	

15		Parameter -10	Value	6908	32 bits float	Read only
16		Parameter -11	Value	6920	32 bits float	Read only
17		Parameter -12	Value	6932	32 bits float	Read only
18		Parameter -13	Value	6944	32 bits float	Read only
19		Parameter -14	Value	6956	32 bits float	Read only
20		Parameter -15	Value	6968	32 bits float	Read only
21		Parameter -16	Value	6980	32 bits float	Read only
22		Parameter -17	Value	6992	32 bits float	Read only
23		Parameter -18	Value	7004	32 bits float	Read only
24		Parameter -19	Value	7016	32 bits float	Read only
25		Parameter -20	Value	7028	32 bits float	Read only
26		Parameter -21	Value	7040	32 bits float	Read only
27		Parameter -22	Value	7052	32 bits float	Read only
28		Parameter -23	Value	7064	32 bits float	Read only
29		Parameter -24	Value	7076	32 bits float	Read only
30		Parameter -25	Value	7088	32 bits float	Read only
31	IED-2	Parameter -1	Value	7100	32 bits float	Read only
32	IED-3	Parameter -1	Value	7400	32 bits float	Read only
33	IED-4	Parameter -1	Value	7700	32 bits float	Read only
34	IED-5	Parameter -1	Value	8000	32 bits float	Read only
35	IED-6	Parameter -1	Value	8300	32 bits float	Read only
36	IED-7	Parameter -1	Value	8600	32 bits float	Read only
37	IED-8	Parameter -1	Value	8900	32 bits float	Read only
38	IED-9	Parameter -1	Value	9200	32 bits float	Read only

39	IED-10	Parameter -1	Value	9500	32 bits float	Read only
----	--------	--------------	-------	------	---------------	-----------

Table-10.8.5: Register details for sensors and IED connected to serial port ETH.

## 10.9 Measured Parameters and IED Communication Status

Sr. No	Parameter	Register Address	Type	Read/ Write
1	Analog inputs Quality - mA	10450	16 bits Unsigned Integer	Read only
2	Analog inputs Quality - mV	10451	16 bits Unsigned Integer	Read only
3	Analog inputs Quality - V	10452	16 bits Unsigned Integer	Read only
4	Analog inputs Quality – Battery Voltage	10453	16 bits Unsigned Integer	Read only
5	Digital Inputs	10454	16 bits Unsigned Integer	Read only
6	IED Communication Status – Serial Port RS485-1	10455	16 bits Unsigned Integer	Read only
7	IED Communication Status – Serial Port RS485-2	10456	16 bits Unsigned Integer	Read only
8	IED Communication Status – Serial Port RS232 – ASCII	10457	16 bits Unsigned Integer	Read only
9	IED Communication Status – Serial Port RS232 – MODBUS	10458	16 bits Unsigned Integer	Read only
10	IED Communication Status – Port ETH	10459	16 bits Unsigned Integer	Read only

Table-10.9: Inputs and IED Communication status MODBUS registers

## 10.10 Solar Parameters (Float 32)

Sr. No	Parameter	Attribute	Register Address	Type	Read/ Write
1	Sunshine duration for the day	Total time in seconds	15050	32 bits float	Read only
2	Sun Rise time for the day	Hours for the day	15052	32 bits float	Read only
3	Sun Set time for the day	Hours for the day	15054	32 bits float	Read only
4	Day duration	Hours	15056	32 bits float	Read only
5	Day solar Energy	Wh/Mtr2	15058	32 bits float	Read only
6	Today Rainfall	mm	15060	32 bits float	Read only

7	Solar Noon Time	Time in seconds	15062	32 bits float	Read only
8	Solar Plant Energy Generation	W	15064	32 bits float	Read only
9	Sun Rise Civil Time	Hours for the day	15066	32 bits float	Read only
10	Sun Set Civil Time	Hours for the day	15068	32 bits float	Read only

Table-10.10: Solar Parameters

### 10.11 Albedo Parameters

Sr. No	Parameter	Attribute	Register Address	Type	Read/Write
1	Albedo Meter-1	Calculated Albedo Ratio	15070	32 bits float	Read only
2	Albedo Meter-2		15072	32 bits float	Read only
3	Albedo Meter-3		15074	32 bits float	Read only
4	Albedo Meter-4		15076	32 bits float	Read only

Table-10.11: Albedo Parameters

### 10.12 Today Solar Energy Parameters

Sr. No	Parameter	Attribute	Register Address	Type	Read/Write
1	Today Solar Energy-1	Integrated solar energy from the selected solar irradiation source	15078	32 bits float	Read only
2	Today Solar Energy-2		15080	32 bits float	Read only
3	Today Solar Energy-3		15082	32 bits float	Read only
4	Today Solar Energy-4		15084	32 bits float	Read only
5	Today Solar Energy-5		15086	32 bits float	Read only
6	Today Solar Energy-6		15088	32 bits float	Read only
7	Today Solar Energy-7		15090	32 bits float	Read only
8	Today Solar Energy-8		15092	32 bits float	Read only
9	Today Solar Energy-9		15094	32 bits float	Read only
10	Today Solar Energy-10		15096	32 bits float	Read only

11	Today Solar Energy-11		15098	32 bits float	Read only
12	Today Solar Energy-12		15100	32 bits float	Read only

Table-10.12: Today Solar Energy Parameters

### 10.13 Solar Parameters (Unsigned 16)

Sr. No	Parameter	Attribute	Register Address	Type	Read/Write
	Sunshine Duration	Total time in Hours	15104	Unsigned 16 bits	Read only
		Total time in Minutes	15105	Unsigned 16 bits	Read only
		Total time in Seconds	15106	Unsigned 16 bits	Read only
1	Sun Rise Time	Total time in Hours	15107	Unsigned 16 bits	Read only
2		Total time in Minutes	15108	Unsigned 16 bits	Read only
3		Total time in Seconds	15109	Unsigned 16 bits	Read only
4	Sun Set Time	Total time in Hours	15110	Unsigned 16 bits	Read only
5		Total time in Minutes	15111	Unsigned 16 bits	Read only
6		Total time in Seconds	15112	Unsigned 16 bits	Read only
7	Day Duration	Total time in Hours	15113	Unsigned 16 bits	Read only
8		Total time in Minutes	15114	Unsigned 16 bits	Read only
9		Total time in Seconds	15115	Unsigned 16 bits	Read only
10	Solar Noon Time	Total time in Hours	15116	Unsigned 16 bits	Read only
11		Total time in Minutes	15117	Unsigned 16 bits	Read only
12		Total time in Seconds	15118	Unsigned 16 bits	Read only
13	Sun Rise Civil Time	Total time in Hours	15119	Unsigned 16 bits	Read only
14		Total time in Minutes	15120	Unsigned 16 bits	Read only
15		Total time in Seconds	15121	Unsigned 16 bits	Read only

16	Sun Set Civil Time	Total time in Hours	15122	Unsigned 16 bits	Read only
17		Total time in Minutes	15123	Unsigned 16 bits	Read only
18		Total time in Seconds	15124	Unsigned 16 bits	Read only

#### 10.14 Datalogger Status Parameters

Sr. No	Parameter	Register Address	Type	Read/ Write
1	Device HW version	15500	Unsigned 32 bits	Read only
2	Device SW version	15502	Unsigned 32 bits	Read only
3	ETH Port Status	15504	Unsigned 32 bits	Read only
4	ETH Port Status Epoch Time	15506	Unsigned 32 bits	Read only
5	Gateway Link Status	15508	Unsigned 32 bits	Read only
6	Gateway Link Status Epoch Time	15510	Unsigned 32 bits	Read only
7	Modem Registration Status	15512	Unsigned 32 bits	Read only
8	Modem Signal Strength	15514	Signed 32 bits	Read only
9	Modem Status Update Epoch Time	15516	Unsigned 32 bits	Read only
10	PPP Link Status	15518	Unsigned 32 bits	Read only
11	PPP Link Status Epoch Time	15520	Unsigned 32 bits	Read only
12	MQTT Status	15522	Unsigned 32 bits	Read only
13	MQTT Status Epoch Time	15524	Unsigned 32 bits	Read only
14	MQTT Pending Messages	15526	Unsigned 32 bits	Read only
15	MQTT Pending Messages Epoch Time	15528	Unsigned 32 bits	Read only
16	RFT1 Status	15530	Unsigned 32 bits	Read only
17	RFT1 Status Epoch Time	15532	Unsigned 32 bits	Read only
18	RFT2 Status	15534	Unsigned 32 bits	Read only
19	RFT2 Status Epoch Time	15536	Unsigned 32 bits	Read only

Table-10.13: Datalogger status parameters MODBUS Registers

## 11. MLogger Error Diagnostics

Configuration and operation of MLogger is quite simple. It can be easily configured using the default settings and sensor/ IED library.

Some of the probable problems and solutions are listed below.

### 11.1 Download Datalogger Status and Values Report:

Download status report and logged messages as shown in sec. 7.7.1. and sec. 7.7.2.  
This report will enable better understanding of the problem.

### 11.2 Embedded Web server

Sr. No.	Problem	Solutions
1	Unable to login to MLogger	Check that the proper IP set in the data logger is being used. Try default data logger IP. Confirm that there is no IP clash in the network. Check that the IP set is as per network class. If the user has closed the webpage without logout – wait for <b>about three minutes</b> before attempting the next login.
2	Unable to login. Message ‘Data Logger is being configured. Login after some time’.	This message is generated if the user tries to login while the datalogger is being configured. Try to login after 10 to 15 seconds.

Table-11.2: Embedded web server problems

### 11.3 ETH Network

Sr. No.	Problem	Solutions
1	SNTP client not able to update time.	Check that the network gateway has been configured properly and connected to the LAN. Check gateway status on OLED or web server diagnostics. Check availability of internet. Verify NTP server IP set in the MLogger. Verify operation of the NTP server via ping.
2	MODBUS Slave does not respond	Check that MODBUS slave has been enabled – ETH port configuration.
3	MODBUS Slave becomes inactive after some time.	Check polling time of MODBUS TCP master. Polling time should be more than 500 msec. Reply delay should be more than 500 msec. Check if the number of clients exceeds the allowed limit.

		Check by using communication log for MODBUS TCP Slave
--	--	---

Table-11.3: ETH Network problems

## 11.4 Datalogger Modem

Sr. No.	Problem	Solutions
1	Modem is unable to register to the network.	<p>Check cellular signal strength via OLED or webserver diagnostic.</p> <p>Connect the antenna securely and place the antenna to get the best signal strength.</p> <p>Verify that the SIM is inserted properly.</p> <p>Verify correct selection of cellular service provider.</p> <p>Check that there is enough balance in the SIM for data communication</p>

Table-11.4: Data Logger Modem

## 11.5 Datalogger GPS

Sr. No.	Problem	Solutions
1	GPS does become active	<p>Verify that modem and GPS are enabled.</p> <p>GPS synchronisation takes 2-3 minutes. Please wait for this time</p> <p>Make sure that the GPS antenna is exposed to the sky without any obstruction.</p>

Table-11.5: Data logger GPS

## 11.6 Analog Input Channels

Sr. No.	Problem	Solutions
1	Analog input channel is showing wrong value	<p>Verify that the analog signal is connected to proper terminal of the datalogger.</p> <p>Verify polarity of the signal connected to the terminals.</p> <p>Check for sensor/ IED type selection and its proper range selection</p>
2	Analog input 4-20mA channel is showing values with bad quality.	Verify that a proper signal is present on the terminals. The mA signal input should be within 4 to mA.
3	Analog input 4-20mA channel is showing value -4444.4 with bad quality.	Sensor is not connected, or the sensor wire is broken. The mA signal input is less than 4 mA.
4	Analog input 4-20mA channel is showing value 8888.8 with bad quality.	The mA signal input is more than 20 mA.

Table-11.6: Analog input channels

## 11.7 Digital Input Channels

Sr. No.	Problem	Solutions
1	Digital input channel is not being detected	<p>Verify that the digital signal is connected to proper terminal of the datalogger.</p> <p>Verify polarity of the signal connected to the terminals.</p> <p>Check that input signal frequency is within the specified range.</p> <p>Confirm that digital signal source is of open collector or potential free contact type.</p>
2	Digital input channel is showing values with bad quality.	Check for sensor/ IED type selection and its proper range selection
3	Multiple pulses are detected on each operation of digital input	<p>This happens due to contact chattering of the digital input signal source.</p> <p>Check the digital signal source relay.</p>

Table-11.7: Digital input channels

## 11.8 Sensor and IED Interfaced to Serial Ports (RS485 and RS232)

Sr. No.	Problem	Solutions
1	Not able to read parameters from sensor/ IED.	<p>Check communication status with IED on OLED or webserver.</p> <p>Confirm that proper RS485 cable (twisted pair cable, shielded and low capacitance) has been used.</p> <p>Verify that one end of the communication cable shield is earthed.</p> <p>Check for proper RS485 communication loop connection.</p> <p>Verify MODBUS ID of the IED has been configured properly.</p> <p>Check that all IED on the RS485 communication loop have a unique MODBUS ID.</p>
2	Wrong values read from the sensor/ IED	<p>Check for sensor/ IED type selection and its proper range selection</p> <p>Verify parameter register addresses has been configured.</p> <p>Verify proper register length (16 or 32 bits) and types (signed or unsigned) has been configured.</p> <p>Check communication with IED by logging MODBUS RTU communication messages.</p>

Table-11.8: Sensor and IED interfaced to serial ports (RS485 or RS232)

## 11.9 Sensor and IED Interfaced to ETH Port

Sr. No.	Problem	Solutions
1	Not able to read parameters from sensor/ IED.	Verify that the IP Address of the IED is configured properly. Check network link with IED via ping. Check for other problems as <u>mentioned in 10.5 above</u> . Check MODBUS TCP Master communication messages

Table-11.9: Sensor and IED interface to ETH port

## 11.10 File Transfer Operation

Sr. No.	Problem	Solutions
1	File transfer not OK.	Check the media for file transfer Modem of ETH. If modem is selected – check that no problem exists <u>with modem</u> . If ETH is selected – check problems with <u>ETH network</u> . Verify configuration of IP, username and passwords for remote file servers. Check file servers with ping

Table-11.10: File transfer Operation

## 11.11 Datalogging Operation

Sr. No.	Problem	Solutions
1	SD Card problem	Check SD Card status on OLED or webserver. Check that the SD card is inserted properly. Put Off the datalogger, remove the SD card. Verify operation of SD card on PC or laptop. If required, format the SD card. Remember to save the logger files prior to formatting the SD card.
2	SD Card is present but data log files are not being created.	Put off power to the data logger. Remove SD card. Re-insert the SD card properly. Check that the directory is not full. If the directory is full, <u>Delete</u> unrequired files from the directory.
3	Parameter values are not being logged	Verify that data logging operation is <u>enabled for the remote server</u> . Check if the data log file directory is full. Check configuration for <u>file directory</u> .

		Verify that the parameter has been <u>configured for logging</u> .
4	File Download option button – not being displayed	The file is being used for logging. Try again after some time.

Table-11.11: Datalogging Operation

## 11.12 IOT Data Transfer Operation

Sr. No.	Problem	Solutions
1	Data not communicating via IOT.	Check that IOT has been enabled. If modem is selected – check that no problem exists <u>with modem</u> . If ETH is selected – check problems with <u>ETH network</u> . Verify configuration of IP, username and passwords for the IOT broker. Confirm that the broker is operational.

Table-11.12: IOT Operation

For other problems please contact [service@mbcontrol.com](mailto:service@mbcontrol.com) .

## 12. MBLogger Library

List of libraries of sensors and IED provided in MBLogger is provided below.

Option of ‘Input Not Used’ is provided for all inputs, if the same is not used.

### 12.1. Library for Digital Input Channels

List of sensors for digital input is provided in table-12.1 below.

Sr. No.	Sensor Type	Make and Model Number
1	Status Input	
2	Rain Gauge	Barani Design
3		Lufft
4		Campbell TB4_MML4
5		Campbell TE525WS_L5
6		Davis 6466
7		HTA RD200
8		Other rain gauge
9	Wind Speed	Wind Sensor
10		MeteoWind Compact Wind Speed Sensor
11		Davis Vantage Pro2
12		LSI DNA202
13		Other wind speed sensor
14	RPM	Speed RPM

Table-12.1: Library of Sensors for digital input channels

## 12.2 Library for Analog mA Input Channels

List of sensors for analog input (mA) is provided in table-12.2 below.

Sr. No.	Sensor Type	Make and Model Number
1	Other Sensor	Sensor of any other make.
2	PV Module Temperature	MBCS MBMet 802
3		HS MSPT1005
4	Ambient Temperature	MBCS MBMet 901BA – temperature
5		MBCS MBMet 901CA – temperature
6		MBCS MBMet 902AW – temperature
7		MBCS MBMet 902BW – temperature
8		HS TSSR_01
9		Delta Ohm HD9009TRR
10	Ambient Humidity	MBCS MBMet 901BA – humidity
11		MBCS MBMet 901DA – humidity
12		MBCS MBMet 902AW – humidity
13		Delta Ohm HD9008TRR
14	Wind Speed	MBCS MBMet 120A Wind Speed
15		MBCS MBMet 100AA Wind Speed
16		MBCS MBMet 100AB Wind Speed
17		MBCS MBMet 140A Ultra Sonic Wind Speed
18		Theis Wind Speed Vwind420
19		Equinox EQ FST201
20	Wind Direction	MBCS MBMet 120A Wind direction
21		MBCS MBMet 110AA Wind direction
22		MBCS MBMet 110AB Wind direction
23		MBCS MBMet 140A Ultra Sonic Wind Direction
24		Theis Wind Direction Rwind420
25		Rika RK110
26		Equinox EQ FST202
27		Other Wind Direction Sensor
28	Pyranometer	Kipp &Zonnen SMP10
29		Kipp &Zonnen SMP11
30		Huskeflux SR2002
31		Huskeflux SR05
32		Igenierburo SI420
33		DeltaOhm LPPYRA03AC
34		Eko MS80SA
35		MBCS MBMet-500AA, MBCS MBMet-500BA and MBCS MBMet-500CA_DA
36		Eko MS80 using MB1375-20
37		Kipp Zonnen CMP10 using MB1375-20
38	Test Input 4-20mA	Used for testing the channel. Value is displayed in range 400 to 2000 based on input mA.

Table-12.2: Library of Sensors for analog input mA channels

## 12.3 Library for Analog mV Input Channels

List of sensors for analog input (mV) is provided in table-12.3 below.

Sr. No.	Sensor Type	Make and Model Number
1	Other Sensor	Sensor of any other make.
2	Pyranometer	Kipp &Zonnen SMP10V
3		Kipp &Zonnen SMP11V
4		Kipp &Zonnen SMP3
5		Kipp &Zonnen CMP10(i)
6		Kipp &Zonnen CMP3
7		Huskeflux SR20T1
8		Huskeflux SR05DA1
9		Epogee SP-110 SS. Calibration constant is 200 micro volt /w/mtr <sup>2</sup>
10		DeltaOhm LPPYRA03AV (0-1000mV)
11		DeltaOhm LPPYRA03(i)
12		EKO MS80(i)
13	Test Input 0-19 mV	Used for testing and calibration of the channel. Value is displayed in range 0 to 1900 based on input mV.
14	Test Input 0-39 mV	Used for testing and calibration the channel. Value is displayed in range 0 to 39000 based on input mV.
15	Test Input 0-75 mV	Used for testing and calibration the channel. Value is displayed in range 0 to 75000 based on input mV.
16	Test Input 0-150 mV	Used for testing and calibration the channel. Value is displayed in range 0 to 150000 based on input mV.
17	Test Input 0-310mV	Used for testing the channel. Value is displayed in range 0 to 310000 based on input mV.
18	Test Input 0-2000mV	Used for testing the channel. Value is displayed in range 0 to 2000000 based on input mV.

Table-12.3: Library of Sensors for analog input mV channels

Note:

Calibration constant is provided for each pyranometer by the manufacturer.  
Micro volts /watt/mtr<sup>2</sup>

## 12.4 Library for Analog Voltage Input Channels

List of sensors for analog input (voltage) is provided in table-12.4 below.

Sr. No.	Sensor Type	Make and Model Number
1	Other Sensor	Sensor of any other make.
2	Wind Speed	MBCS MBMet 100CA Wind Speed
3		MBCS MBMet 100CB Wind Speed
4		MBCS MBMet 100DA Wind Speed

5		MBCS MBMet 100DB Wind Speed
6		Theis Vwind 10
7		Davis Vantage Pro2
8	Wind Direction	MeteoWind Compact Wind Sensor
9		MBCS MBMet 110CA Wind direction
10		MBCS MBMet 110CB Wind direction
11		MBCS MBMet 110DA Wind direction
12		MBCS MBMet 110DB Wind direction
13		Barani MeteoWind Compact Wind Direction
14		Theis Rwind 10
15		Other Wind Direction Sensor
16	Pyranometer	Igenieurburo SIV10T
17		DeltaOhm LPPYRA03AV: 0-5V
18		DeltaOhm LPPYRA03AV: 0-10V
19	Cloud Cover Sensor	PCCD Okta
20	Test Input 0-10V	Used for testing the channel. Value is displayed in range 0 to 10000 based on input V.

Table-12.4: Library of Sensors for analog input voltage channels

## 12.5 Library for Sensors/ IED for RS485 Ports MODBUS – RTU Protocol

List of sensors/IED for RS485 ports having MODBUS RTU protocol is provided here.

### 12.5.1 Ambient Parameter Sensors

List of ambient parameters sensors for RS485 ports is provided in table-12.5.1 below.

Sr. No.	IED Type	Make and Model Number
1	Other Sensor	Sensor of any other make.
2	Ambient Temperature, Humidity and Pressure	MBCS MBMet 901AB
3	Ambient Temperature and Humidity	MBCS MBMet 901BB
4	Ambient Temperature	MBCS MBMet 901CB
5	Ambient Humidity	MBCS MBMet 901DB
6	Ambient Pressure	MBCS MBMet 901EB
7	Ambient Temperature and Humidity	Elektronic EE071
8	Humidity	Delta Ohm HD9008T175
9	Ambient Temperature, Humidity and Pressure	Meteo Temp
10	Ambient Temperature	Micros WSB181DIN

Table-12.5.1: Library of ambient parameter sensors for RS485 ports

### 12.5.2 PV Module Sensors

List of PV module sensors for RS485 ports is provided in table-12.5.2 below.

Sr. No.	IED Type	Make and Model Number
1	PV Module Temperature	MBCS MBMet 803

Table-12.5.2: Library of PV module sensors for RS485 ports

### 12.5.3 Wind Speed and Direction Sensors

List of wind speed and direction sensors for RS485 ports is provided in table-12.5.3 below.

Sr. No.	IED Type	Make and Model Number
1	Wind Speed	MBCS MBMet 100BA
2		MBCS MBMet 100BB
3		MBCS MBMet 140B US – ultra sonic
4		MBMet-807 with Wind Speed sensor
5	Wind Direction	MBCS MBMet 110BA
6		MBCS MBMet 110BB
7	Wind Speed and Direction	MBCS MBMet 120B
8		MBCS MBMet 130B
9		MBCS MBMet 140HB
10		MBCS MBMet 140B Ultrasonic
11		Barani Wind Speed and Direction
12		MBCS MBMet 140B V2 Ultrasonic
13		Luft Venius V200
14		GILL GMX200

Table-12.5.3: Library of wind speed and direction sensors for RS485 ports

### 12.5.4 Pyranometers

List of pyranometer for RS485 ports is provided in table-12.5.4 below.

Sr. No.	IED Type	Make and Model Number
1	Pyranometer	Kipp &Zonnen SMP3 (i)
2		Kipp &Zonnen SMP10 (i)
3		Kipp &Zonnen SMP11 (i)
4		Huskeflux SR20D2
5		Huskeflux SR05
6		Igenieurburo ST RS485
7		MBCS MBMet-500AB, MBCS MBMet-500BB and MBCS MBMet-500CB_DB
8		EKO MS80S_S
9		EKO MS80S_M
10		EKO MS60S_S
11		EKO MS60S_M
12		EKO MS40S_S
13		EKO MS40S_M
14		MBCS MBMet 500AB
15		MBCS MBMet 500BB
16		MBCS MBMet 500CB_DB
17		MBCS MBMet 500AB_V1
18		MBCS MBMet 500BB_V1
19		MBCS MBMet 500CB_DB_V1
20		Ref Cell NES SOZ-03

Table-12.5.4: Library of pyranometers for RS485 ports

Notes:

- i) For Kipp and Zonnen pyranometers, default measurement resolution is set to ‘1’. User should configure the measurement resolution as per settings in the pyranometer.

### 12.5.5 Inverters

List of inverters for RS485 ports is provided in table-12.5.5 below.

Sr. No.	IED Type	Make and Model Number
1	Inverter	SMA Devices ScnnHE20
2		Sungrow Series 5G

Table-12.5.5: Library of inverters for RS485 ports.

### 12.5.6 MFM

List of MFM for RS485 ports is provided in table-12.5.6 below.

Sr. No.	IED Type	Make and Model Number
1	MFM	Satec PM130EHP
2		Satec EM133

Table-12.5.6: Library of MFM for RS485 ports

### 12.5.7 Rain Gauge

List of Rain Gauges for RS485 ports is provided in table-12.5.7 below.

Sr. No.	Senor Type	Make and Model Number
1	Rain Gauge	Model ZRG10
2		MBCS MBmet-807 with Rain gauge

Table-12.5.7: Library of Rain Gauge for RS485 ports

### 12.5.8 Smart Box

List of Smart Boxes for RS485 ports is provided in table-12.5.8 below.

Sr. No.	Senor Type	Make and Model Number
1	Smart Box	Model Smart Box – 1448

Table-12.5.8: Library of Smart Box for RS485 ports

### 12.5.9 Soil Sensors

List of Soil Sensors for RS485 ports is provided in table-12.5.9 below.

Sr. No.	Senor Type	Make and Model Number
1	Soil Sensors	MB-RK-520-1

Table-12.5.9: Library of Soil Sensors

### 12.5.10 Solar Monitoring System

List of solar monitoring system for RS485 ports is provided in table-12.5.10 below.

Sr. No.	Senor Type	Make and Model Number
1	Solar Monitoring System	Kipp & Zonnen Razon Plus

Table-12.5.10: Library of solar monitoring system for RS485 ports

## 12.6 Library for Sensors/ IED for RS232 Port– ASCII Protocol

List of sensors/IED for RS232 ports having ASCII protocol is provided here.

### 12.6.1 Wind Parameter Sensors

List of wind sensors having ASCII Master protocol is provided in table-12.6.1 below.

Sr. No.	Senor Type	Make and Model Number
1	Other Sensor	Sensor of any other make.
2	Wind Parameter sensor	Ultrasonic Air Sensor 81000. 3D air parameter sensor – ASCII Master protocol
3		Ultrasonic Air Sensor Theta AR200
4		Windsonic

Table-12.6.1: Library of wind parameter sensors for RS232 port

### 12.6.2 Cloud Cover Sensors

List of Clou Cover sensors having ASCII Slave protocol is provided in table-12.6.2 below.

Sr. No.	Senor Type	Make and Model Number
1	Other Sensor	Sensor of any other make.
2	PCCD Optical Sensors	PCCD Optical Sensors – cloud cover ensor. ASCII Slave protocol.

Table-12.6.2: Library of clod cover sensors for RS232 port

## 12.7 Library for Sensors/ IED for RS232 Port – MODBUS RTU Protocol

List of sensors/IED for RS232 ports having MODBUS RTU protocol is provided here.

### 12.7.1 Visibility Distance Sensor

List of visibility distance sensors having MODBUS RTU protocol is provided in table-12.7.1 below.

Sr. No.	Senor Type	Make and Model Number
1	Visibility Sensor	Hongview HySLV2E

Table-12.7.1: Library of visibility distance sensors for RS232 port – MODBUS RTU protocol

## 12.8 Library for Sensors/ IED for ETH Ports – MODBUS TCP Protocol

List of sensors/IED for ETH port having MODBUS TCP protocol is provided here.

### 12.8.1 MFM

List of MFM for ETH port is provided in table-12.8.1 below.

Sr. No.	Senor Type	Make and Model Number
1	MFM	Satec PM130EHP

Table-12.8.1: Library of MFM for ETH port

### 12.8.2 Inverters

List of inverters for ETH port is provided in table-12.8.2 below.

Sr. No.	Senor Type	Make and Model Number
1	Inverter	SMA Devices ScnnHE20

Table-12.8.2: Library of inverters for ETH port

## 12.8.3 Solar Monitoring System

List of solar monitoring system for ETH port is provided in table-12.8.3 below.

Sr. No.	Senor Type	Make and Model Number
1	Solar Monitoring System	Kipp &Zonnen Razon Plus

Table-12.8.3: Library of solar monitoring system for ETH port

## 12.9 Special Function – Sunrise and set time – States and Locations.

List of states and locations in India, configured in the data logger library are listed in table 12.9 below.

Sr. No.	State / Union Territory	Locations
1	Andhra Pradesh	Anantapur, Vijayawada, Tirupati
2	Andaman Nicobar	Port Blair
3	Arunachal Pradesh	Itanagar
4	Assam	Guwahati, Jorhat
5	Bihar	Patna, Purnia
6	Chandigarh	Chandigarh
7	Chhattisgarh	Raipur
8	Dadra and Nagar	Dadra and Nagar
9	Delhi	Delhi
10	Goa	Panjim
11	Gujrat	Ahmedabad, Jamnagar, Surat
12	Haryana	Panipat, Sirsa
13	Himachal Pradesh	Baddi, Shimla
14	Jammu and Kashmir	Jammu, Srinagar
15	Jharkhand	Ranchi
16	Karnataka	Bengaluru, Belari, Mangalore, Raichur
17	Kerala	Kochi, Kozhikode
18	Ladakh	Leh
19	Lakshadweep	Kavaratti
20	Maharashtra	Mumbai, Nagpur, Jalna, Kolhapur
21	Madhya Pradesh	Bhopal, Gwalior, Indore, Rewa
22	Manipur	Imphal
23	Meghalaya	Shillong
24	Mizoram	Aizawl
25	Nagaland	Kohima
26	Odisha	Bhubaneswar, Rourkela
27	Punjab	Amritsar, Patiala, Ludhiana
28	Rajasthan	Bikaner, Jaipur, Pali, Udaipur
29	Sikkim	Gangtok
30	Tamil Nadu	Chennai, Madurai, Nagercoil
31	Telangana	Hyderabad, Warangal
32	Tripura	Agartala

33	Uttar Pradesh	Agra, Gorakhpur, Lucknow, Meerut, Varanasi
34	Uttarakhand	Dehradun
35	West Bengal	Durgapur, Kolkata, Siliguri

Table-12.9: States and cities in India for sunrise and set time calculation.

## 13. Revision History

Rev.	Date	Description
R1	2020-10-01	Day log files status column removed.
		Remote files status column removed.
		Following sensors added to library (mA input) – MBMET 902-AW and MBMET 902-BW.
		Section added for MODBUS Slave register addresses.
		Parameter log header description details added.
	2020-10-04	My Page Parameters – option for protocol selection removed
	2020-10-10	Software version changed to 1.05
	2020-10-12	Limits added for number of IED parameters.
R2	2020-10-12	Software version changed to 1.06. Calibration constant added for Pyranometers. Total number of parameters increased from 150 to 200. Number of files in each directory increased from 60 to 90.
R3	2020-10-17	Software version changed to 2.01. Calculated solar parameters added. Sunshine duration added.
	2020-10-22	Soil sensors added to library
R4	2020-12-06	Software version changed to 2.07
R5	2021-03-25	Software version changed to 2.19. Sensors added to library for mA, Voltage inputs. IED added RS485 inputs.
R6	2021-06-20	Software version changed to 2.21. Serial port RS232 – MODBUS RTU Master and MODBUSRTU Slave protocols added.
R7	2021-07-04	Software version changed to 2.22. PCCD – Optical sensors added to library. RS232 port connection diagram rectified.
R8	2021_07_13	Software version changed to 4.01. Option to select time zone has been added to SNTP configuration.
R9	2021_08_07	Software version changed to 4.06. Device name added.
R10	2021_10_30	Software version changed to 4.16. Display value as 8888.8 with bad quality if mA input exceeds 20mA. Update device / sensors library

R11	2021_11_24	Software version changed to 4.20. Sensor library updated. Site name added. MODBUS RTU Master added in RS232 Port
R12	2021_12_15	Test input ranges added for mV input. My page parameters selection changed to select parameter attribute. All inputs value quality MODBUS Slave register added. ALL IED communication status MODBUS Slave register added.
R12	2022_03_16	Software version changed to 4.35. Sensor input high voltage field made editable for Barani design Wind Direction sensor. Jumper option provided for setting default IP in the datalogger. Applicable only for dataloggers with hardware version 3.10 and above.
R13	2024_07_20	IOT feature added Sensor Library updated “Media Format Option” added
R14	2024_08_26	Number of MyPage parameters increased to 36 Other IED allowed to have Solar Irradiation Parameters
R15	2024_08_28	Device Messages updated
R16	2026_05_22	Unsigned 16 register added for Solar Plant time parameters.

Table-13: Revision History