

EDL175

Portable Event & Data Logger- Extended Range



Installation & Operation Manual

LIMITED WARRANTY

The manufacturer offers the customer a 24-month functional warranty on the instrument for faulty workmanship or parts from date of dispatch from the distributor. In all cases, this warranty is valid for 36 months from the date of production. This warranty is on a return to factory basis.

The manufacturer does not accept liability for any damage caused by instrument malfunction. The manufacturer accepts no responsibility for the suitability of the instrument to the application for which it was purchased.

Failure to install, setup or operate the instrument according to the instructions herein will void the warranty.

Your instrument may be opened only by a duly authorized representative of the manufacturer. The unit should only be opened in a fully anti-static environment. Failure to do so may damage the electronic components and will void the warranty.

NOTE

The greatest care has been taken to manufacture and calibrate your instrument. However, these instructions do not cover all possible contingencies that may arise during installation, operation or maintenance, and not all details and variations of this equipment are covered by these instructions.

For additional information regarding installation, operation or maintenance of this instrument, contact the manufacturer or your local representative or distributor.

This manual provides instructions for using the EDL175. For instructions and information on using the PM175, refer to the PM175 Installation and Operation Manual; for instructions and information on using the PAS software package, refer to the PAS User's Manual included in the accompanying CD for the PM175 Series.

BG0447 REV. A1

Table of Contents

1. The Portable Event & Data Logger - Extended Range	4
2. Installation	8
2.2 Connecting to the Electrical Network	8
2.3 Connecting Voltage and Current Inputs	8
2.4 Wiring Mode Setup	8
2.5 CT Setup.....	9
2.5.2 Direct Measurement (via clamps).....	9
2.5.3 Measurement via External CTs Secondary Current, Clamps and Special Cables.....	9
2.6 PT Setup.....	10
2.7 Voltage Probes Connection	10
2.8 Current Sensors Connection.....	10
2.8.1 Standard Clamps.....	10
2.8.2 Special Cables	11
2.8.3 Standard FLEX Current Sensors	11
3. Power Supply and Battery	11
3.1 Internal Battery Power Supply.....	11
3.2 Indicators	11
3.3 Battery Voltage Measurement.....	12
4. Specifications	12

1. The Portable Event & Data Logger - Extended Range

The EDL175 Portable Event & Data Logger - Extended Range measures, records and analyzes events and data of electrical network parameters. Being mobile, it enhances efficiency by enabling onsite identification of power problems. The EDL175 meets the requirements of a wide range of applications, from *events analysis* to *energy auditing* and *load profile recording* over a period of time.

The EDL175 parameters include all the **measurement and logging capabilities** of the PM175 Powermeter in a convenient, portable package. The manufacturer's PAS software package included in the EDL175 provides graphic data display and analysis capabilities.

The EDL175 is suitable for direct measurement of voltages up to 660V (or greater when using a Potential Transformer). The EDL175 is equipped with standard clamps with secondary current of 1A. It is also possible to use FLEX sensors with secondary voltage of 2VAC or 3VAC or standard clamps with secondary voltage up to 2VAC or 3VAC.

The EDL175 can measure **low currents** in the range of **100mA to 10A**, in addition to the standard ranges, with a high degree of accuracy, using **standard high current clamps**. This additional measurement capability is made possible by the combination of standard current clamps and the manufacturer's special cables and electronic circuit. One application is using standard current clamps to measure the standard 5A output CTs.

The EDL175 has an **internal DC battery** which enables it to continue working even when the power supply is disconnected for short intervals, as in a power failure.

The contents of the EDL175 case are shown in *Figures 1-1* through *1-4*. Instrument dimensions are shown in *Figure 1-5*.

Section 2 of this manual provides installation instructions, including wiring mode, CT and PT setup, as well as connection of voltage probes and current sensors. Section 3 provides information on the internal battery and an explanation of the EDL175 indicator lights.

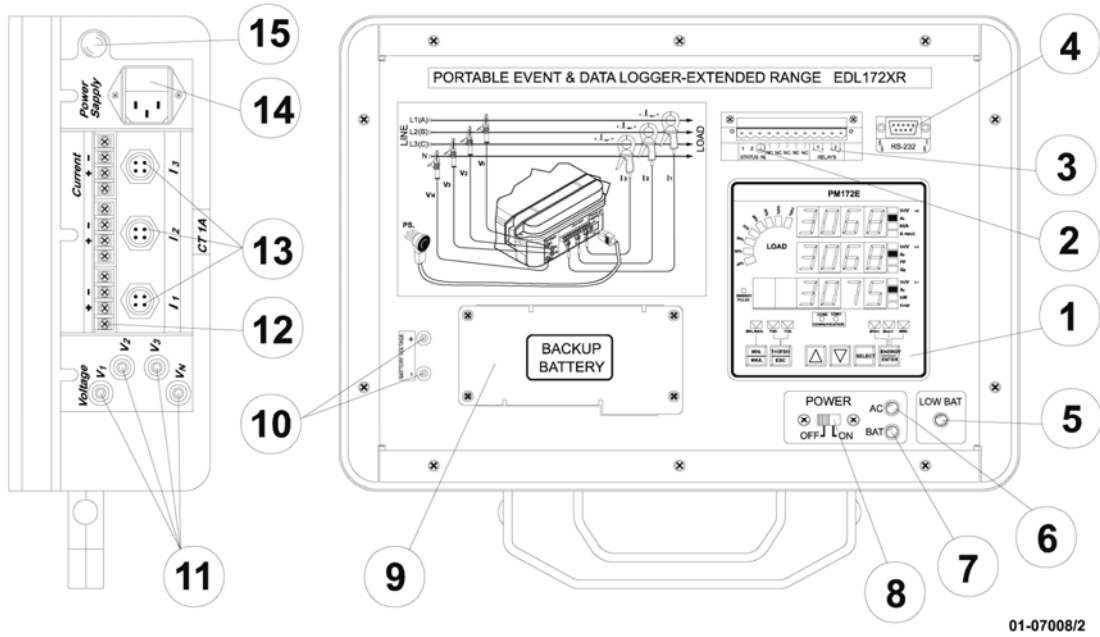

01-07008/2

Figure 1-1 Standard Contents of EDL175

1	EDL175 Display
2	PM175 Status Inputs Connector - see Figure 1-2 for detail
3	PM175 Relays Connector - see Figure 1-2 for detail
4	Communication Port (RS-232)
5	Low battery LED "BAT LOW" (red, blinking) and Buzzer
6	AC Power LED (green)
7	Battery LED "BAT" (red)
8	Slide switch operating voltage supply
9	Battery and Battery Fuse
10	Battery Voltage measurement sockets
11	Voltage inputs
12	Current Terminals
13	Current Inputs
14	Power Supply Socket & Fuse Housing
15	Network neon light

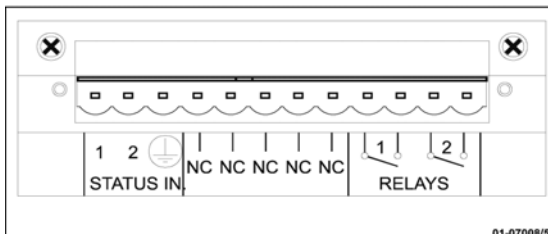

Figure 1-2 Detail of Nos. 2 and 3 in Figure 1-1

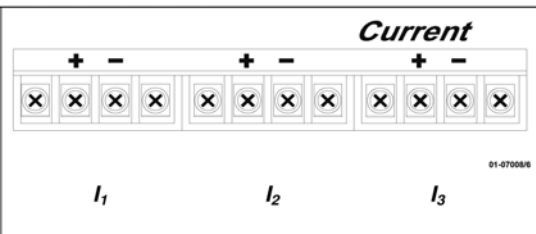
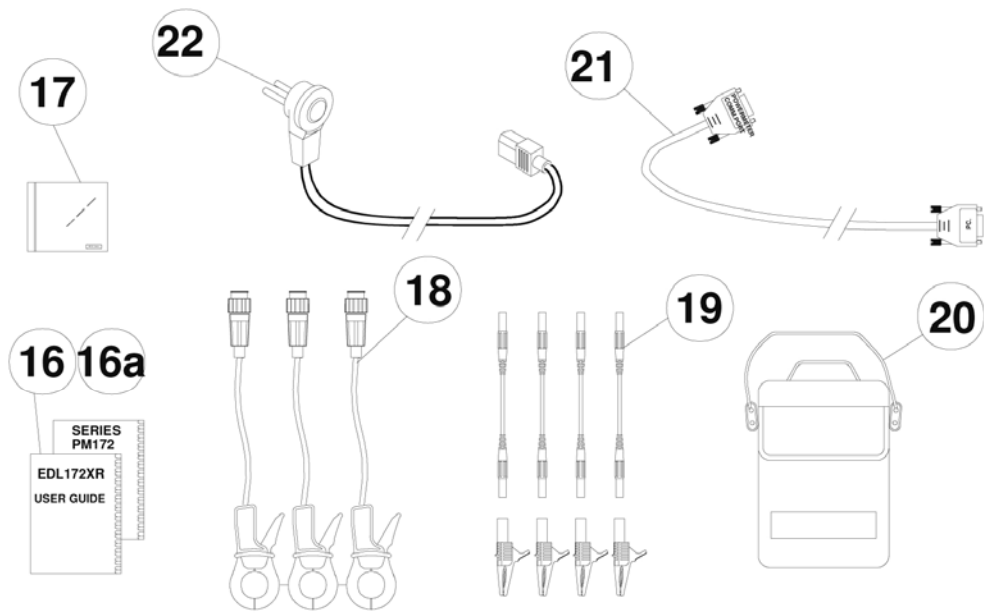
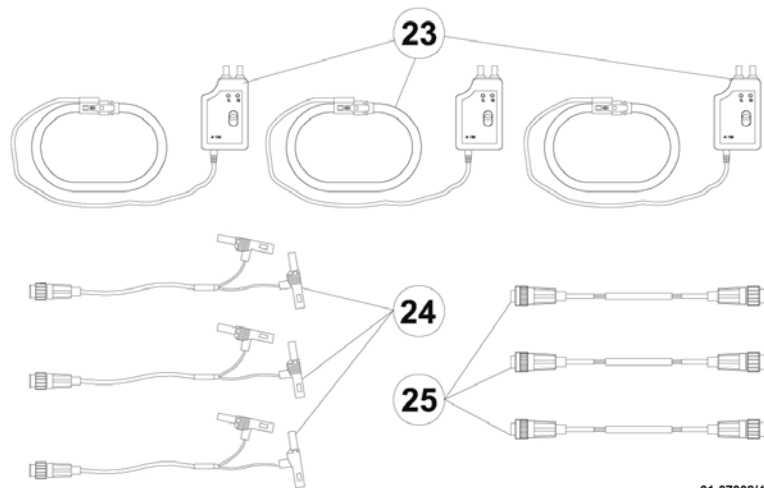

Figure 1-3 Detail of No. 12 in Figure 1-1

NOTE: Connections for relays, status inputs and communications are the same as for the PM175. See the PM175 Installation and Operation Manual for connection drawings and instructions. Analog output is not connected.



01-07008/3



01-07008/4

Figure 1-4 Additional Items

16	EDL175 Installation and Operation Manual
16a	Series PM175 Installation and Operation Manual
17	Series PM175 CD
18	Current Clamps Set
19	Voltage Probe Set
20	Case for Clamps and Cable
21	Communications Cable
22	Power Supply Cord
23	FLEX current sensors
24	Connection Cables for FLEX current sensors
25	Special cables for current clamps for low current measurement (100mA-10A)

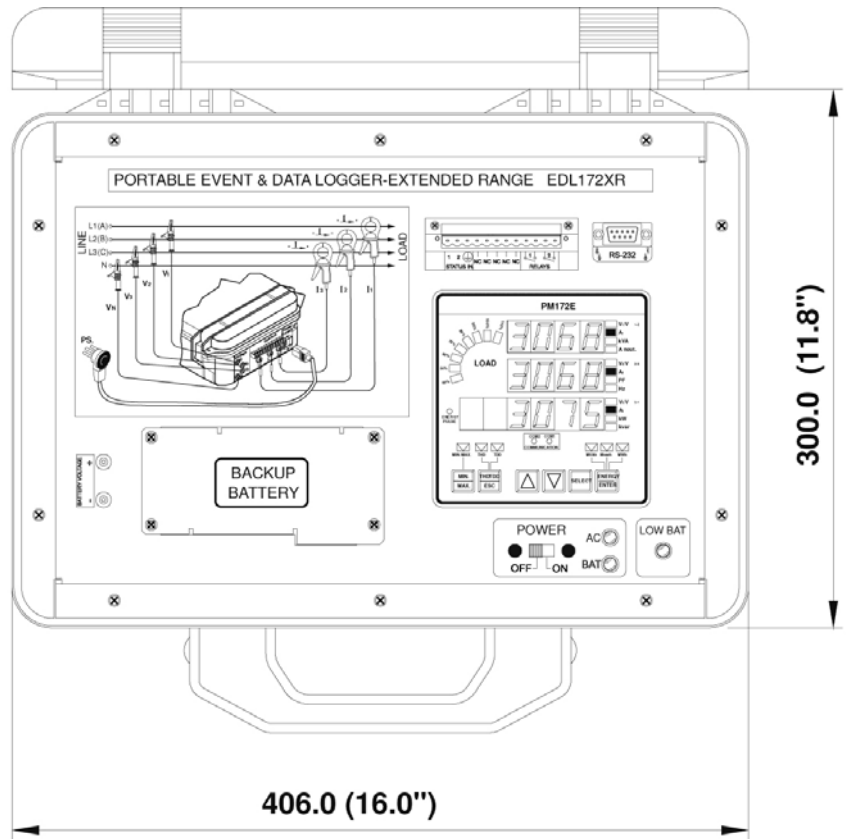
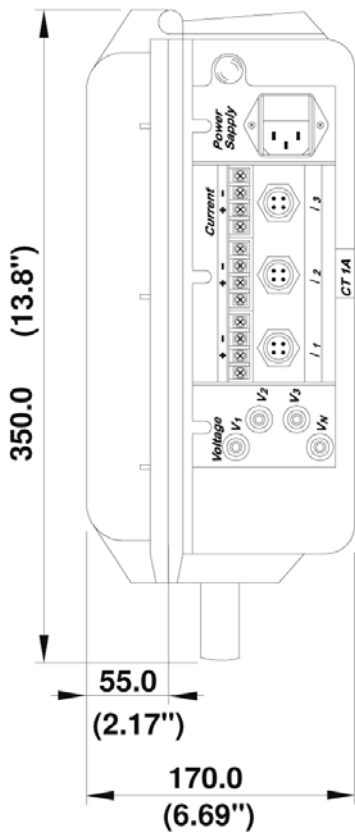

01-07008/8

Figure 1-5 EDL175 Dimensions

2. Installation

Read through this section carefully before connecting the EDL175 to the circuit being tested.

2.1 Location

The distance between the EDL175 and the current lines must be at least half a meter (1.6 feet) for current lines carrying up to 600A, and at least one meter (3.3 feet) for currents between 600A and 2000A.

2.2 Connecting to the Electrical Network

Connect the EDL175 to the AC power supply using the Power Supply Cord (No. 22 on Figure 1-3). Turn the slide switch (No. 8 on Figure 1-1) ON.

2.3 Connecting Voltage and Current Inputs

Voltage Inputs are connected using the cables shown in *Figure 1-4*, no. 19. Current Inputs can be connected by one of four options:

- **Regular Connection** via terminal block, see *Figure 1-1*, no. 12 (same as terminal block of the PM175)
- **Connection via Current Clamps** with current source output signal for high current measurement (see *Figure 1-4*, no. 18)
- **Connection via Current Clamps** with current source output signal **and Special Cable** for low current measurement (see *Figure 1-4*, nos. 18 and 24)
- **Connection via Current Clamps** with voltage source output signal **or via Flexible Current Sensors and Connection Cables for FLEX Current Sensors** (see *Figure 1-4*, nos. 23 and 24)

Note: Even if measuring only one phase current, all current sensors must be connected.

2.4 Wiring Mode Setup

Wiring mode of the EDL175 is the same as for the PM175.

For setup of the wiring mode directly on the EDL175 front panel, refer to Table 4-1 of the *PM175 Installation and Operation Manual* or the *PAS User's Manual*, Section 6.1.1.

2.5 CT Setup

Set up the CT according to the *PM175 Installation and Operation Manual*, Table 4-1 or the *PAS User's Manual*, Section 6.1.1.

2.5.1 Normal Measurement

Set the CT = 1.

2.5.2 Direct Measurement (via clamps)

All clamps require the CT according to the following formula:

$$CT = I_{1ncl} / I_{2ncl}$$

where: I_{1ncl} and I_{2ncl} are the clamp nominal primary and secondary currents.

Examples: 1) $I_{1ncl} = 1000A$ and $I_{2ncl} = 1A$; CT=1000

2) $I_{1ncl} = 1000A$ and $I_{2ncl} = 5A$; CT=200

3) $I_{1ncl} = 200A$ and $I_{2ncl} = 1A$; CT=200

FLEX sensors and clamps with nominal output voltage of **3V** require the CT to be set to the nominal primary current. FLEX sensors and clamps with nominal output voltage of **2V** require the CT to be set to 150% of the nominal primary current.

Examples: 1) $I_{1ncl} = 300A$, $V_{2ncl} = 2V$; CT=150

2) $I_{1ncl} = 3000A$, $V_{2ncl} = 3V$; CT=1500

2.5.3 Measurement via External CTs Secondary Current, Clamps and Special Cables

The CT value should be set according to the following formula:

$$CT = (I_p / I_s) \cdot (I_{1ncl} / I_{2ncl}) \cdot 0.005$$

where:

I_p = external Current Transformer primary nominal current

I_s = external Current Transformer secondary nominal current

Examples:

1. When measuring current without external transformer ($I_p / I_s = 1$) via clamp **1000/1**, then

CT=5, If will be set **CT=5000** the instrument display in mA;

2. When measuring secondary of current transformer **3000/5** via clamp **1000/1**, then

$$I_P = 3000, I_S = 5, I_C = 1000, CT = (3000/5) \cdot (1000/1) \cdot 0.005 = 3000.$$

2.6 PT Setup

Set the PT according to the *PM175 Installation and Operation Manual*, Section 4.1 or the *PAS User's Manual*, Section 6.1.1.

2.7 Voltage Probes Connection

Connect the voltage probes to the EDL175 through the voltage connectors marked $V_1/V_2/V_3/V_N$. Connect the probes to the line conductors according to the power system configuration.

WARNING

The voltage between phases V1, V2, V3 should not exceed 660 VAC RMS (900 VAC peak).

2.8 Current Sensors Connection

Connect the current sensors first to the EDL175 and then to the measured circuit.

There is a common connector for all types of current sensors in each phase.

NOTE: The nominal secondary outputs of the current sensors can be 1A or up to 3V.

WARNING

All clamps provided with the EDL175 include special protection against overvoltage. Do not under any circumstances disconnect the current clamps with current output from their sockets while the clamps are connected to the electrical wires. This can cause fatal injury and equipment damage.

2.8.1 Standard Clamps

The EDL175 contains a set of **standard current clamps** with 1A secondary nominal current and primary nominal current according to the order specification (120A / 200A / 1000A / 3000A).

Maximum EDL175 measured current is 200% of the nominal current.

All current clamps in the kit have built-in protection against clamp connector disconnection.

2.8.2 Special Cables

The manufacturer's special cables, together with the standard clamps, enable the EDL175 to perform measurements on **high voltage lines** via existing current transformers with 5A nominal secondary current by measuring the output of the current transformers.

2.8.3 Standard FLEX Current Sensors

The EDL175 can work with all standard FLEX and clamp current sensors which have a voltage output up to 3V RMS. The EDL175 provides an optional FLEX connector cable for connection to these current sensors.

3. Power Supply and Battery

WARNING

Turn the slide switch OFF when not in use.

3.1 Internal Battery Power Supply

The EDL175 includes a rechargeable battery. When fully charged, the battery allows the EDL175 to work for at least 20 minutes. **Do not allow the battery to totally discharge.** The battery measurement sockets can be used for external 12V battery connection, which will allow prolonged use of the EDL175 in the event of no network power supply.

Charging the Battery

When the battery is fully discharged (indicated by the buzzer, the blinking LOW BAT lamp and, upon end of discharging, by no display), apply AC voltage to the EDL175 to recharge the battery. The recommended charge time is 8 hours.

3.2 Indicators

The following table lists the possible indicated conditions:

Green LED - AC and net- work neon light	Red LED - BAT	Red LED - LOW BAT	PM175 Display	Indication
ON	Off	Off	ON	EDL175 supplied by external AC power supply; battery is charging slowly
Off	ON	Off	ON	EDL175 supplied by internal charged DC battery
Off	ON	Blinking & buzzer	ON	EDL175 supplied by internal DC power supply; battery needs charging and will disconnect automatically within 5 minutes
ON	Off	Off	Off	EDL175 is connected to external AC power supply, slide switch is OFF; battery is charging rapidly

3.3 Battery Voltage Measurement

The amount of remaining battery charge can be estimated by checking battery voltage (Vbat). This is done by connecting an external voltmeter with internal resistance of greater than 1M Ω to the battery measurement sockets (see *Figure 1-1*, no. 10).

If Vbat \approx 12V, the battery is operating normally. If Vbat \approx 11V, the battery is LOW. If Vbat \approx 10.5V, the battery is fully discharged.

4. Specifications

Power supply: 100-240 VAC, 45-65 Hz, 30 VA.

Battery: rechargeable; 12V/1.2Ah DC. Allows 20 minutes work when fully charged. Long-term storage of the battery is according to the following:

Storage temperature	+10°C	+20°C	+30°C	+40°C
Time before recharging required, in months	> 18	14	8	5

Accuracy: The EDL175 accuracy is a function of the accuracies of the PM175, the clamps and the external transformers (PT and CT). Most of the EDL175 measurement error is due to the latter two elements.

Voltage Probe Set: 1 black, 3 red, spring loaded.

Construction: Case material: Polypropylene
Case temperature rating: -23° C to 99° C

Measurements: **Height** 300 mm, 11.8"
Width 406 mm, 16"
Depth 170 mm, 6.7"
Weight 6.3 kg, 14 lbs

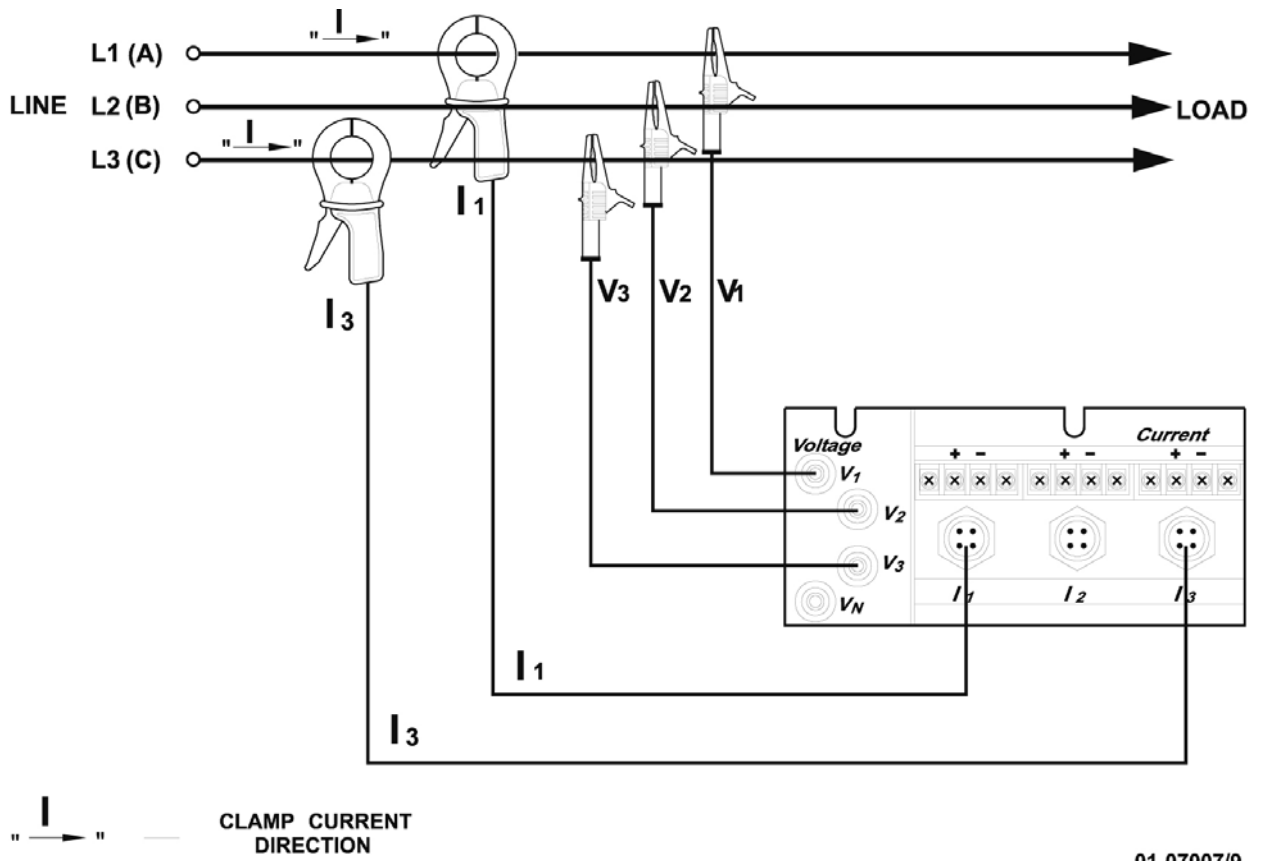

01-07007/9

Figure 2-1 Three wire direct connection using 2 CTs (2-element), Wiring Mode=3dir2

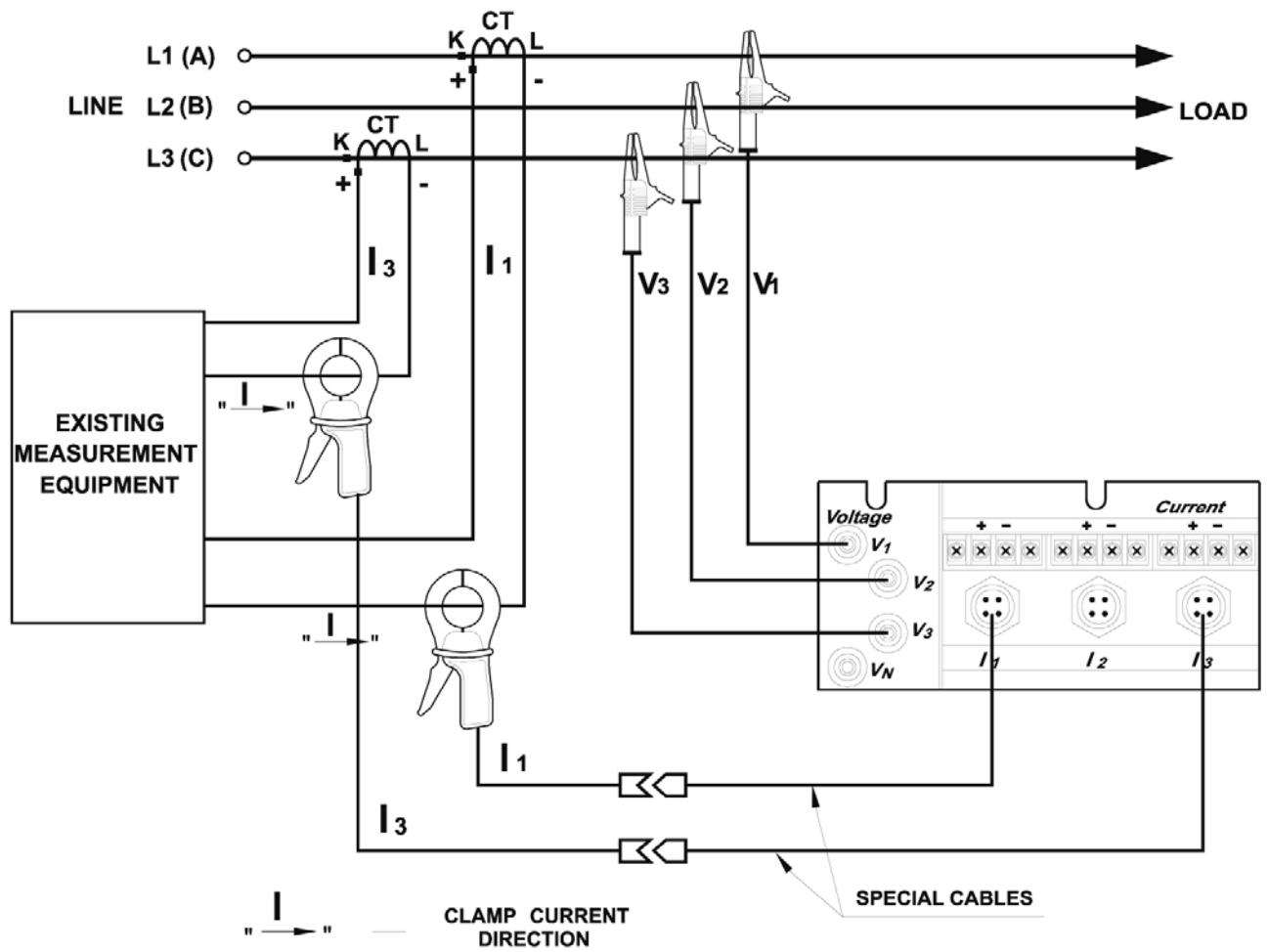

01-07007/1

Figure 2-2 Three wire direct connection with special cable using 2 CTs (2-element), Wiring Mode=3dir2

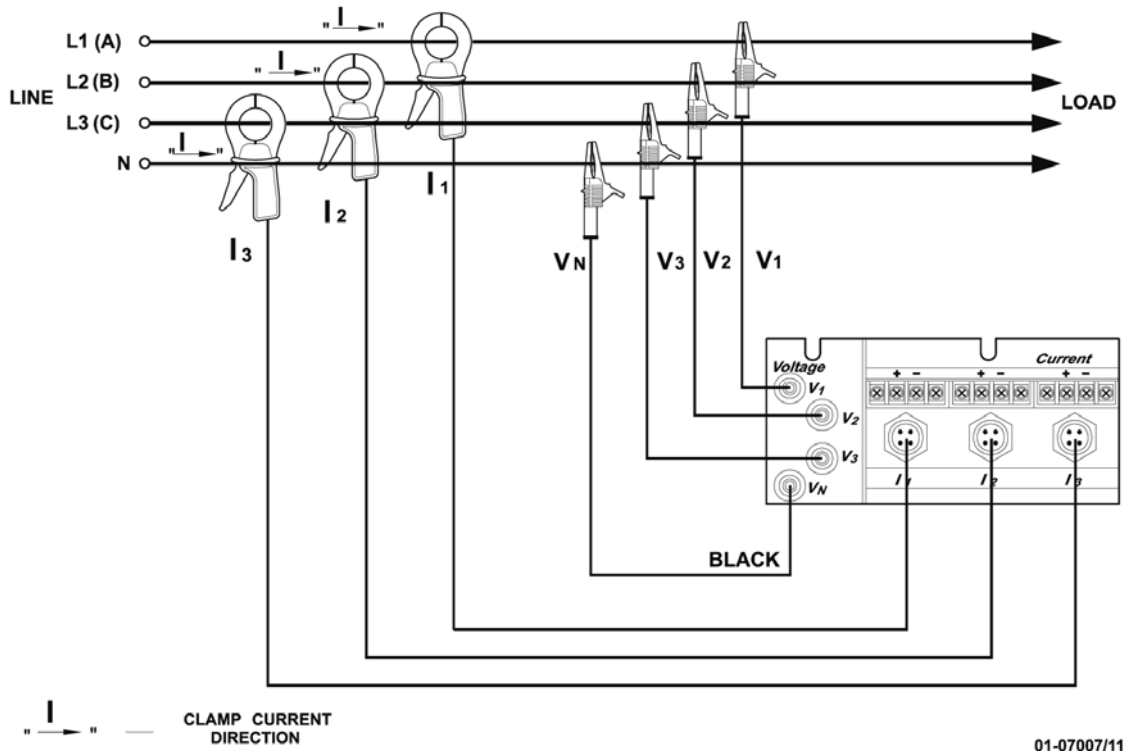

Figure 2-3 Four Wire WYE Direct Connection Using 3 CTs (3-element) Wiring Mode = 4LL3 or 4Ln3

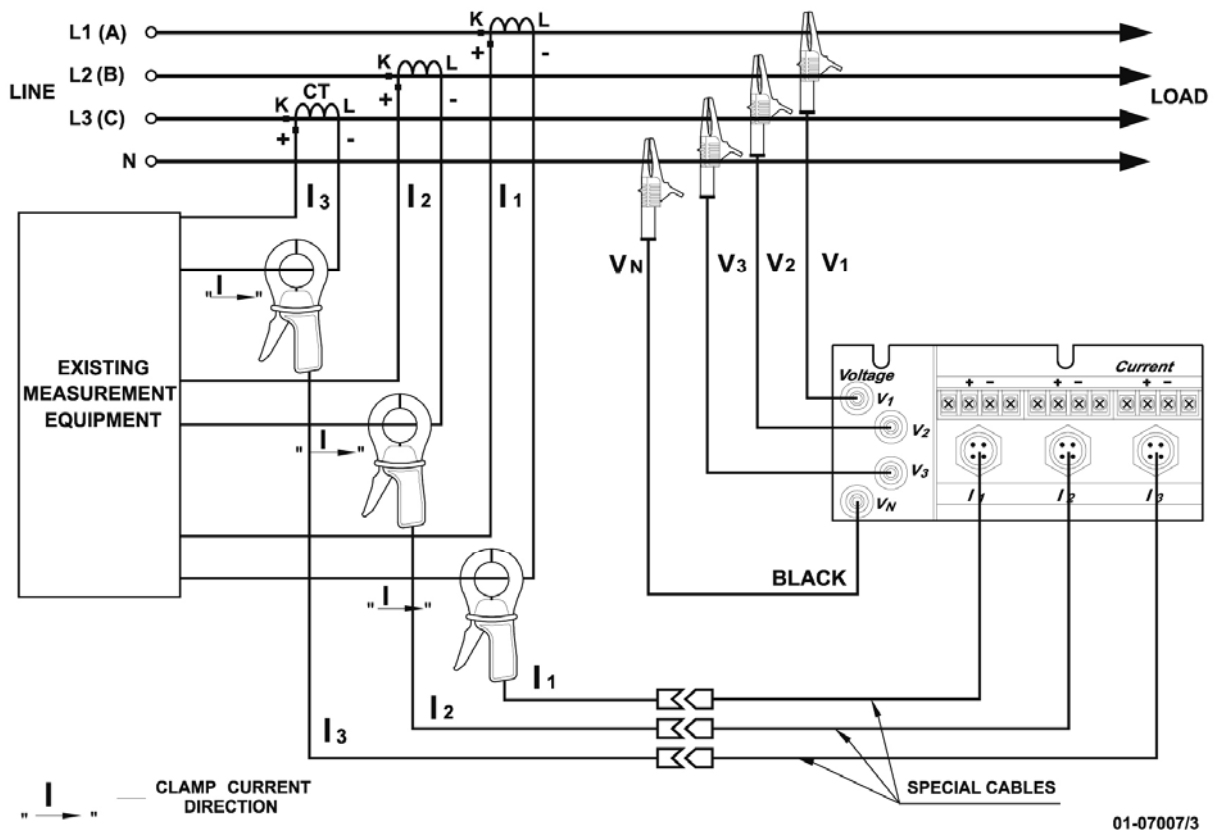

Figure 2-4 Four Wire WYE Direct Connection with special cables using 3 CTs (3-element) Wiring Mode = 4LL3 or 4Ln3

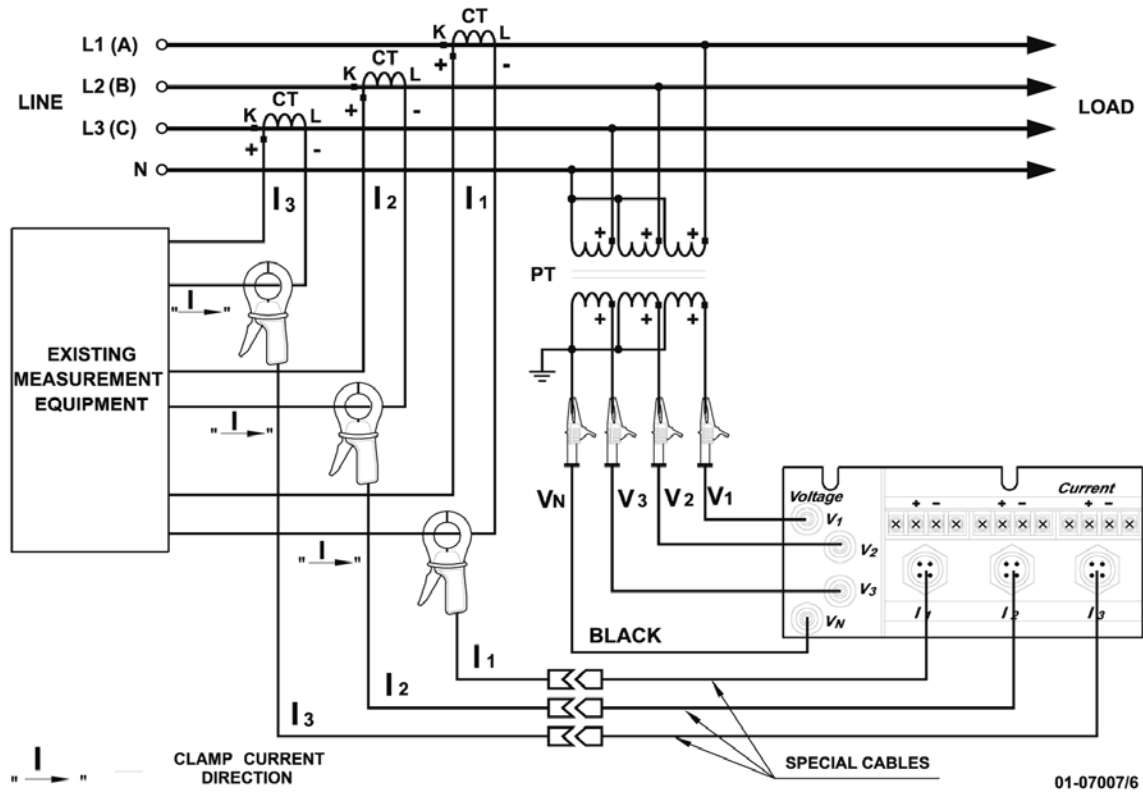
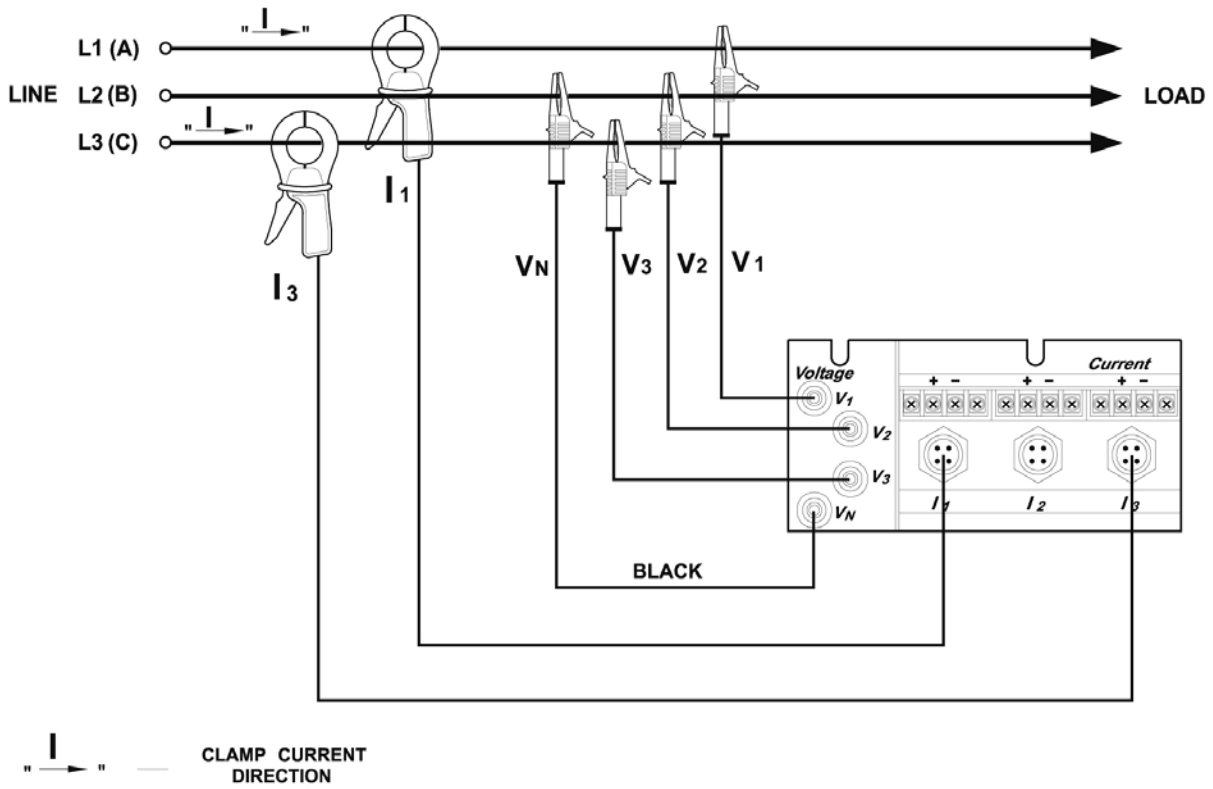
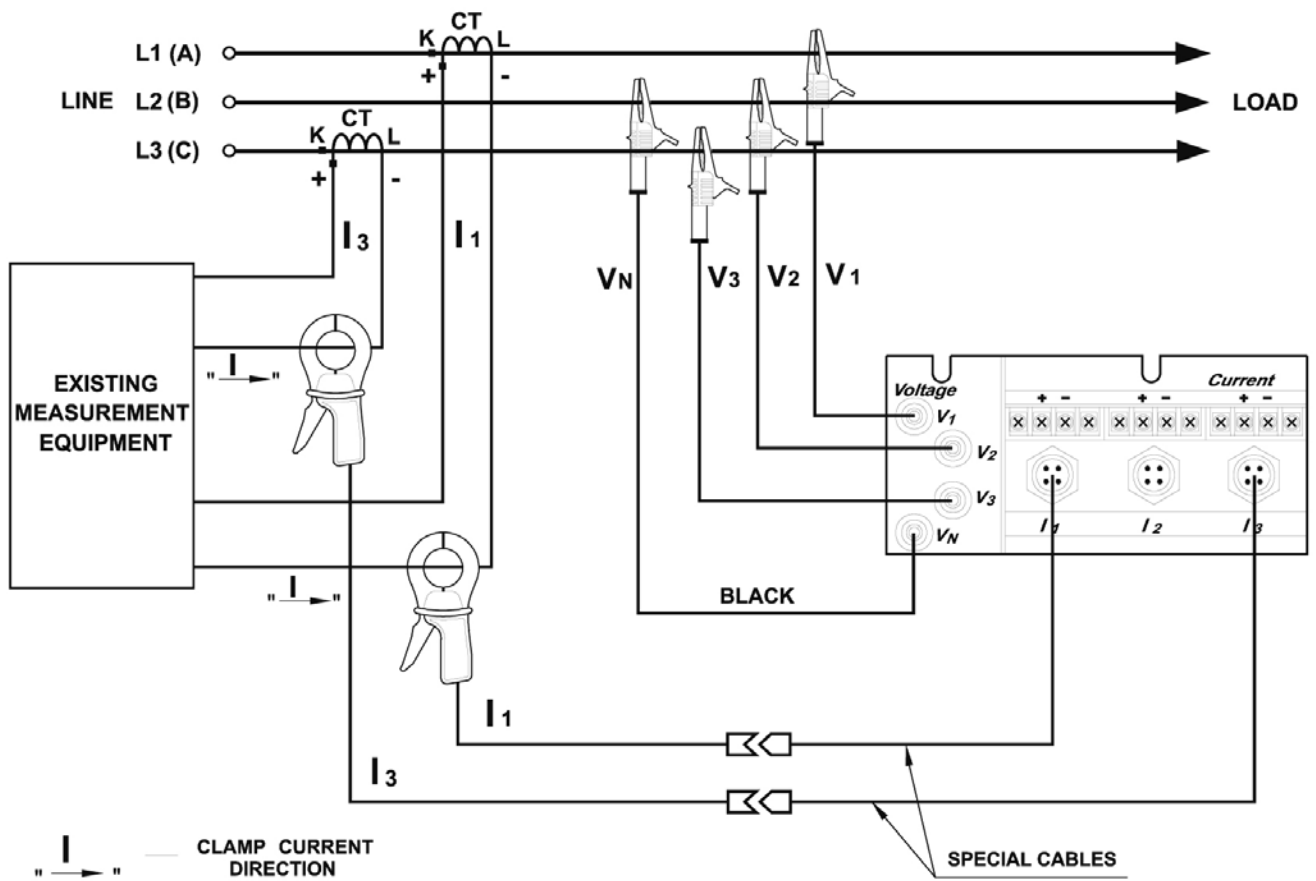

Figure 2-5 Four Wire WYE Connection with special cables using 3 PTs, 3 CTs (3-element) Wiring Mode = 4LL3 or 4Ln3



01-07007/10

Figure 2-6 Three Wire Open Delta Connection using 2 PTs, 2 CTs (2-element) Wiring Mode = 3OP2



01-07007/2

Figure 2-7 Three Wire Open Delta Connection with special cables using 2 PTs, 2 CTs (2-element) Wiring Mode = 3OP2

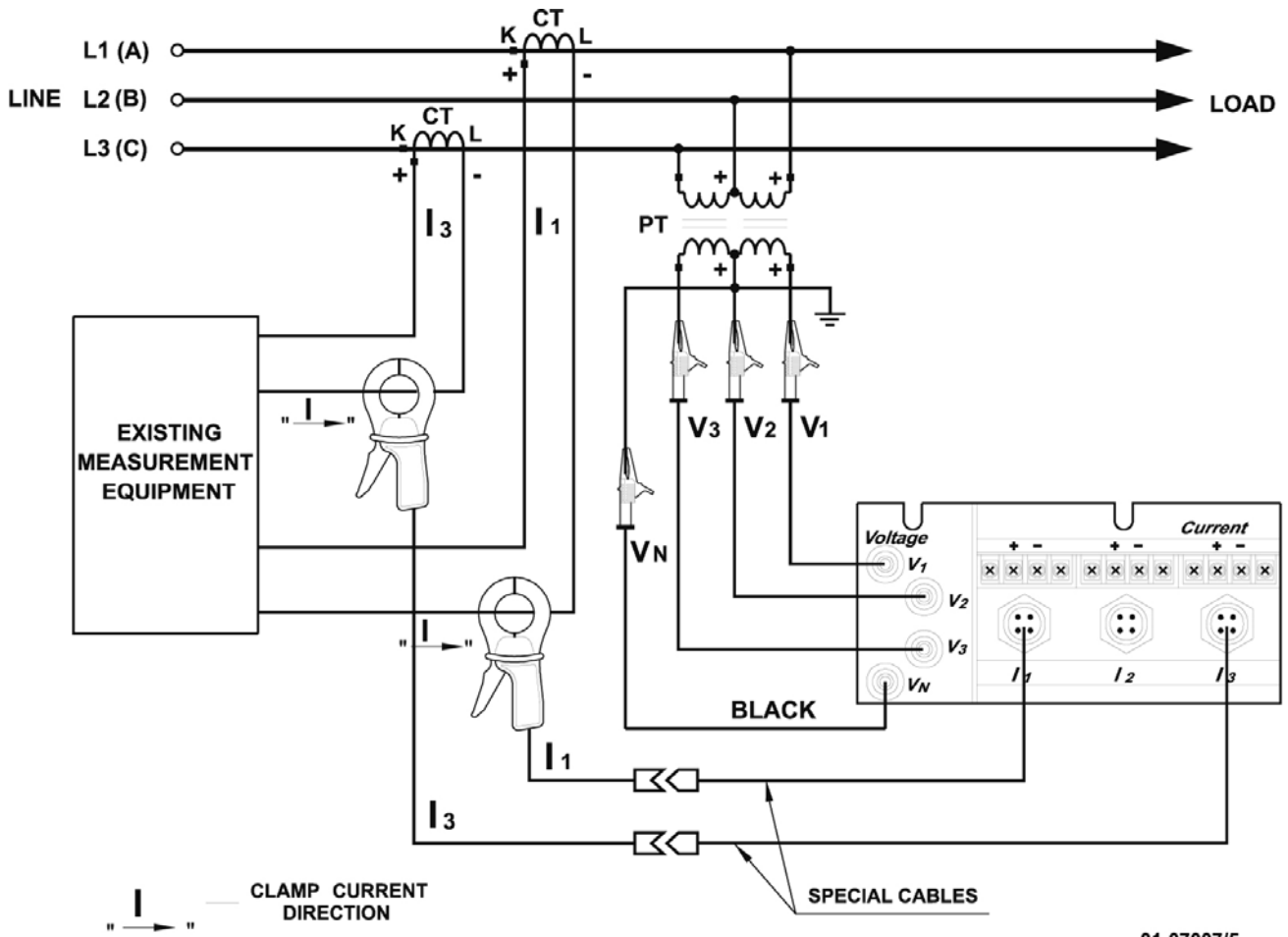

01-07007/5

Figure 2-8 Three Wire Open Delta Connection with special cables using 2 PTs, 2 CTs (2-element) Wiring Mode = 3OP2

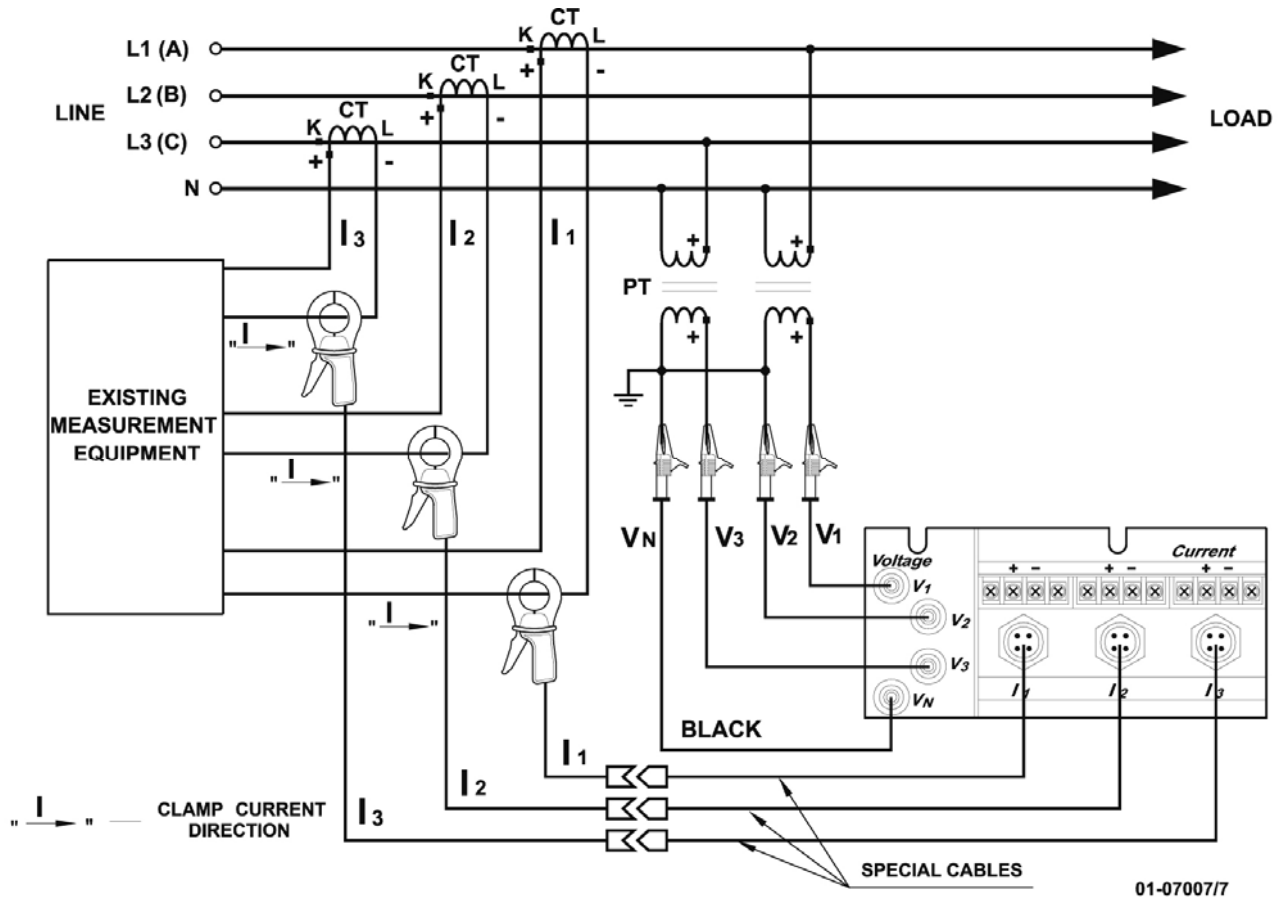

Figure 2-9 Four Wire Wye Connection with special cables using 2 PTs, 3 CTs (2½-element) Wiring Mode = 3LL3 or 3Ln3

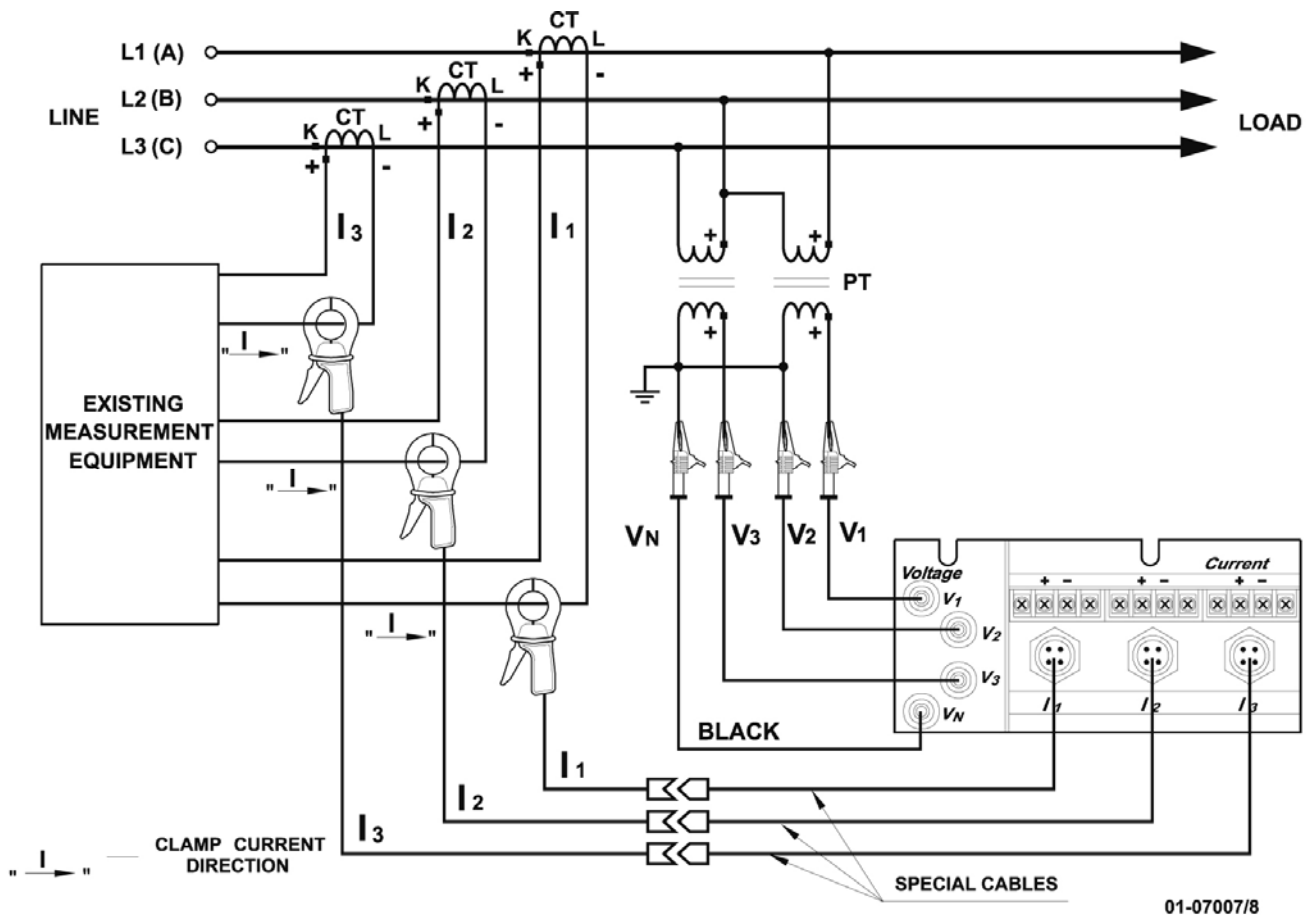

Figure 2-10 Three Wire Open Delta Connection with special cables using 2 PTs, 3 CTs (2½-element) Wiring Mode = 3OP3

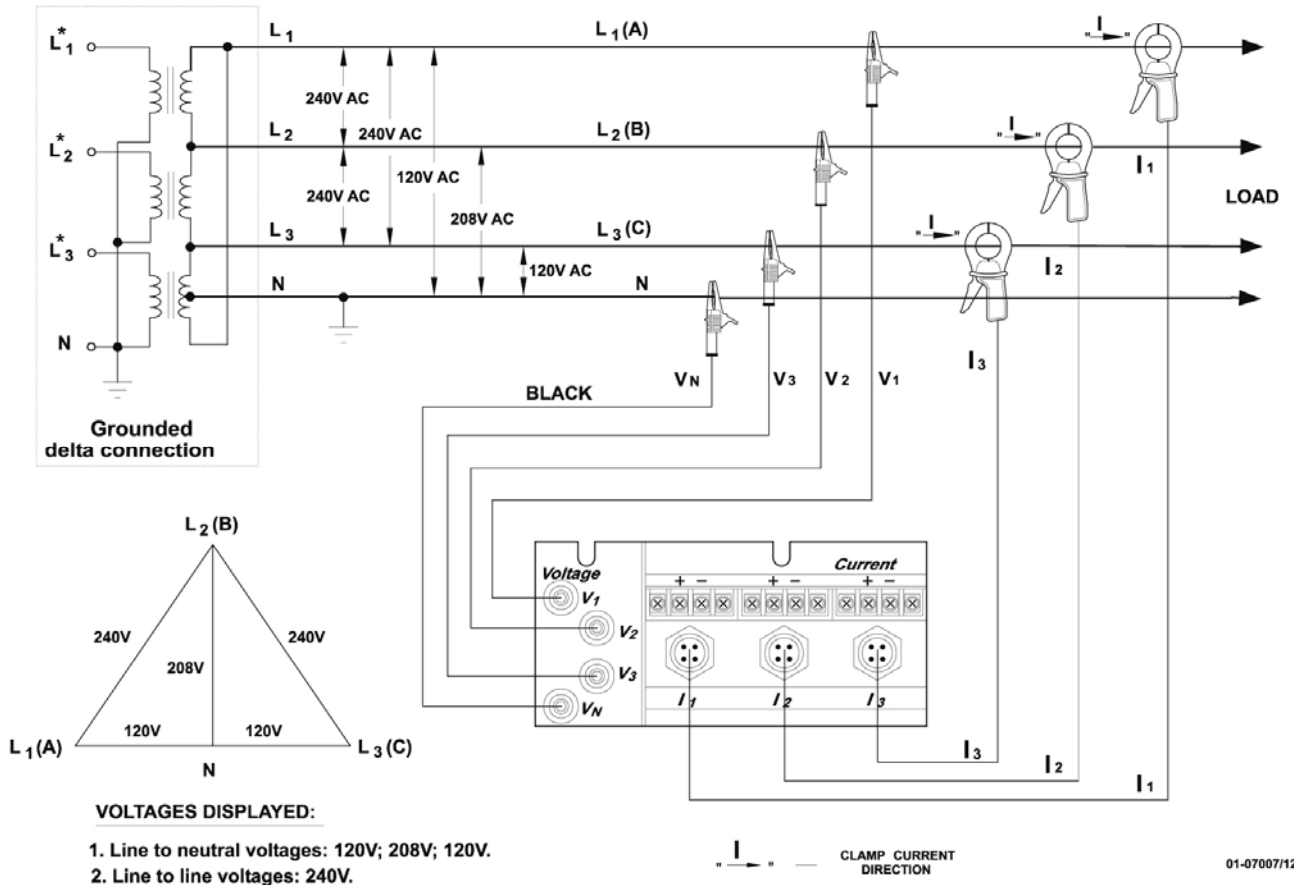

Figure 2-11 Four Wire Delta Direct Connection using 3 CTs (3 element) Wiring Mode = 4LL3 or 4Ln3

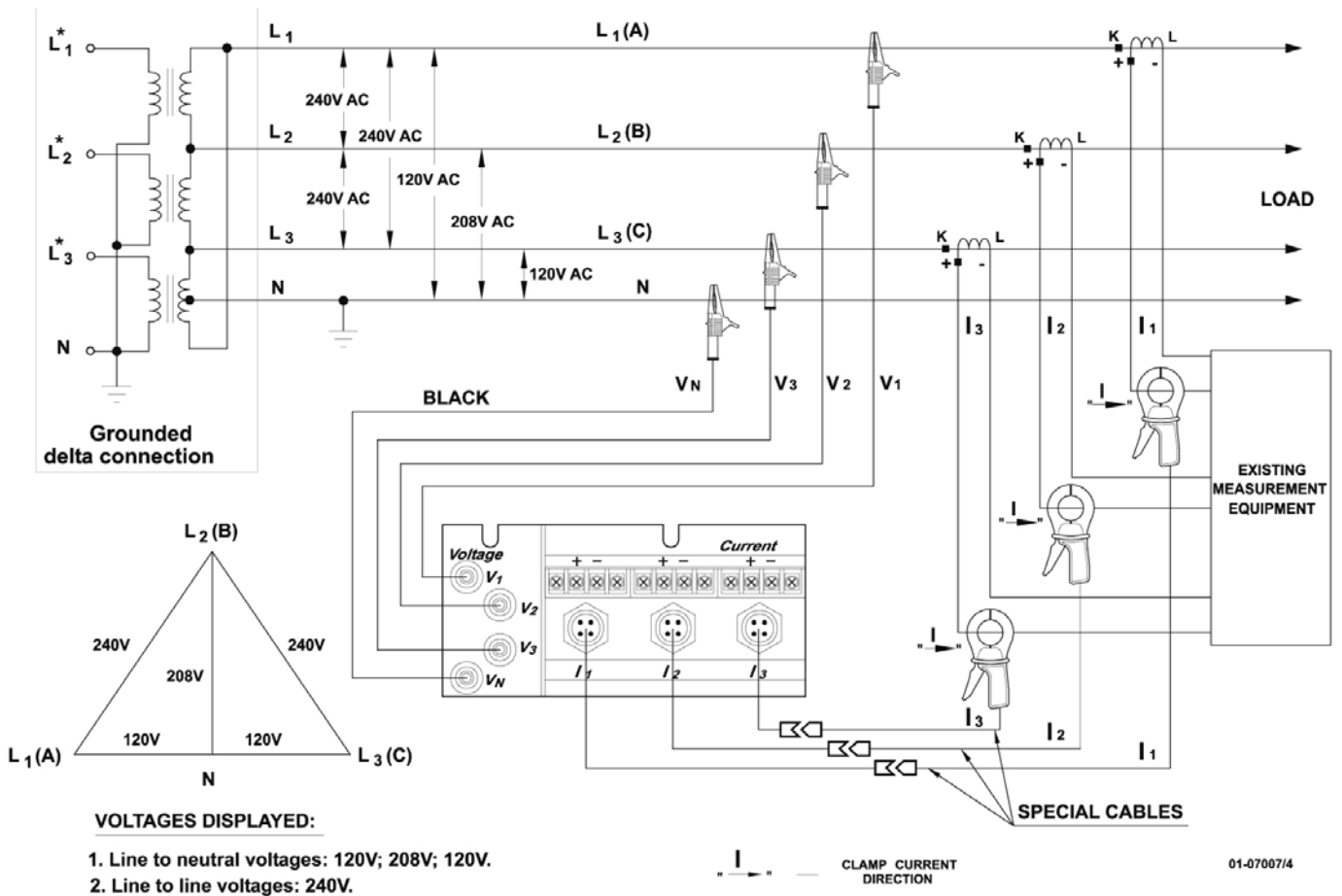

Figure 2-12 Four Wire Delta Direct Connection with special cables using 3 CTs (3 element) Wiring Mode = 4LL3 or 4Ln3