

AX-8
Analog Expander

**Installation
and Operation
Manual**

BG0259 Rev. A5

SATEC

AX-8 Analog Expander



Installation and Operation Manual

LIMITED WARRANTY

The manufacturer offers the customer a 24-month functional warranty on the instrument for faulty workmanship or parts from date of dispatch from the distributor. In all cases, this warranty is valid for 36 months from the date of production. This warranty is on a return to factory basis.

The manufacturer does not accept liability for any damage caused by instrument malfunction. The manufacturer accepts no responsibility for the suitability of the instrument to the application for which it was purchased.

Failure to install, set up or operate the instrument according to the instructions herein will void the warranty.

Your instrument may be opened only by a duly authorized representative of the manufacturer. The unit should only be opened in a fully anti-static environment. Failure to do so may damage the electronic components and will void the warranty.

NOTE

The greatest care has been taken to manufacture and calibrate your equipment. However, these instructions do not cover all possible contingencies that may arise during installation, operation or maintenance, and all details and variations of this equipment are not covered by these instructions.

For additional information regarding installation, operation or maintenance of this equipment, contact the manufacturer or your local representative or distributor.

IMPORTANT





-  **Ensure** that all incoming AC power and other power sources are turned OFF before performing any work on the unit. Failure to do so may result in serious or even fatal injury and/or equipment damage.
-  **Before** connecting the unit to the power source, check the label on the rear to ensure that your unit is equipped with the appropriate power supply.
-  **Do not** connect the unit to a power source if it is damaged.
-  **Do not** expose the unit to rain or moisture.
-  **Read this manual** thoroughly before connecting the unit.

Table of Contents

1 Introduction	1
2 Field Setting	3
2.1 Default Setting.....	3
2.2 Changing the Communication Parameters (Firmware Version 0.10)	3
3 Installation.....	5
3.1 Mechanical Installation.....	5
3.2 Electrical Installation.....	6
4 Operation.....	9
4.1 Power Up	9
4.2 Communication	9
5 Technical Specifications	11

1 Introduction

The AX-8 Analog Expander is an instrument that enables Powermeters to interface with other devices that require analog signals. The AX-8 can be connected to any Powermeter equipped with an RS-422 communication port and analog expander option.

The AX-8 provides up to 8 analog outputs. Two units can be connected in sequence, providing as many as 16 analog outputs with use of one Powermeter¹. For information on analog output and analog expander setup and connections, refer to the Installation and Operation Manual of the specific Powermeter.

Features

Accuracy - The AX-8 provides 8 or 9 bit resolution on each analog output. Output values on all channels are updated continuously at a rate of 0.3 to 0.5 seconds, depending on the speed of communication (baud rate).

Flexibility - The analog outputs are provided with **current output options** of 0-20 mA and 420 mA, 0-1 mA and ± 1 mA , and **voltage output options** of 0-10V DC and ± 10 V DC. Depending on the specific model of Powermeter, a wide range of output values are user-selectable, from the Powermeter front panel or via communications software.

Installation - DIN rail or wall mounting. No auxiliary power supply is required; an internal switching power supply with a wide AC/DC range is provided.

Communications - The AX-8 is connected to the Powermeter using a twisted pair cable via the RS-422 port, using ASCII, Modbus or DNP3.0 protocols. This allows communication over a distance of up to 1000 meters at a baud rate of up to 19,200 bps. Installation of the AX-8 does not interfere with the inclusion of the Powermeter in a communication network (RS-422 or RS-485) of up to 31 Powermeters.

Figure 1-1 shows a typical communication network with two AX-8 expanders.

¹ If your Powermeter supports 7 (14) channels, then the AX-8 will also provide 7 (14) channels.

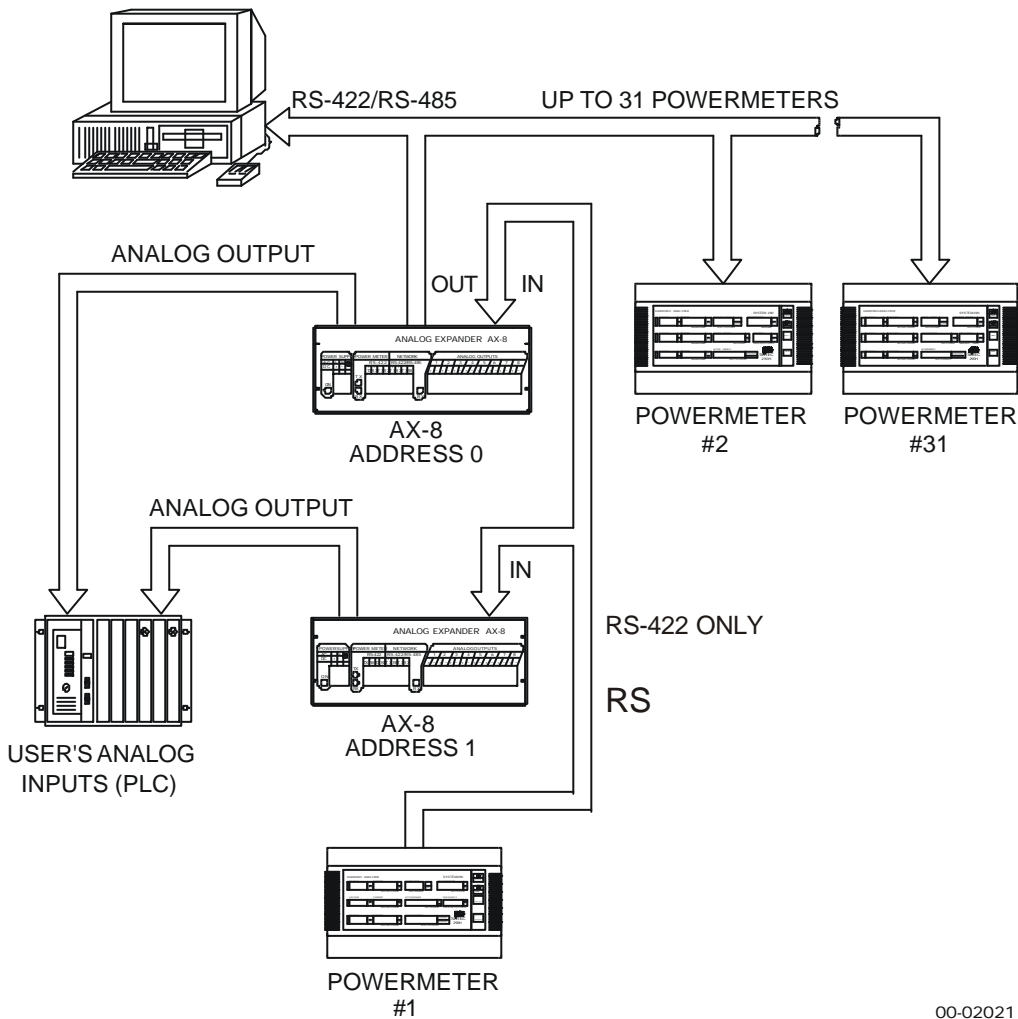

00-02021

Figure 1-1 AX-8 Analog Expanders in a Typical Communication Network

2 Field Setting

2.1 Default Setting

The Analog Expander is set by the dip switches S1 and S2 on the PCB located inside the AX-8 case. The default setting is as follows:

Expander address	0 ¹
Analog output range	factory set as per order
Protocol	ASCII
Data format	8N (8 bit, no parity)
Baud rate	9600 bps

If you require a change to this setting, open the case as per *Sections 2.2 - 2.4* below and change the setting.

2.2 Changing the Communication Parameters (Firmware Version 0.10)

1. Disassemble the AX-8 case: remove the 8 screws from the outside of the case and take off the rear cover.

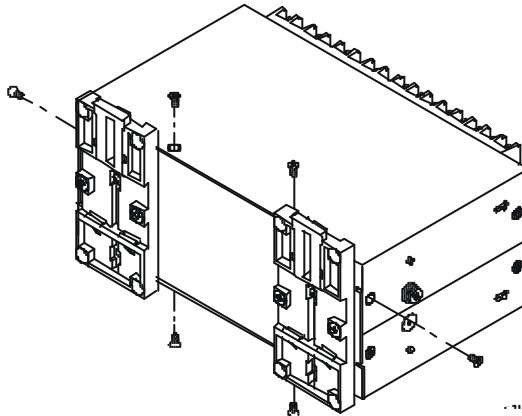

2. Set the DIP switches on the PCB (see *Figure 2-1*) as shown in *Tables 2-1* and *2-2* below.
3. Re-assemble the case: put the rear cover back on, insert and tighten the 8 screws.

¹ This address allows use of up to 7 or 8 analog outputs, according to the analog output setup in the Powermeter. Use of additional outputs from one Powermeter requires installation of an additional AX-8 unit with address '1'.

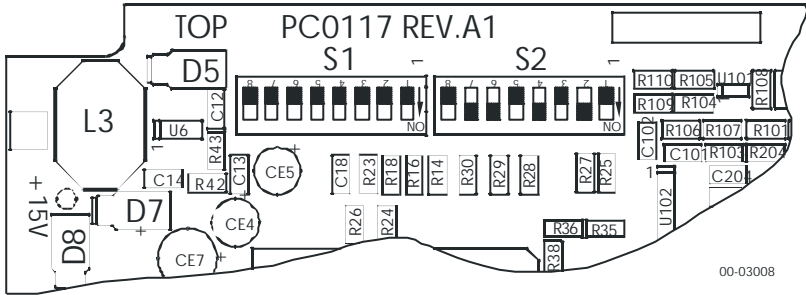

Figure 2-1 Location of Dip Switches on AX-8 PCB

Table 2-1 DIP Switch S1 * = default

AX-8 Option	SW1 Addr0	SW2 Addr1	SW3 Addr 2	SW4 N/A	SW5 N/A	SW6 Factory Set	SW7 Factory Set	SW8 Factory Set
Address 0	OFF	OFF	OFF					
Address 1	<input checked="" type="checkbox"/>	OFF	OFF					
Address 2	OFF	<input checked="" type="checkbox"/>	OFF					
Address 3	<input checked="" type="checkbox"/>	<input checked="" type="checkbox"/>	OFF					
Address 4	OFF	OFF	<input checked="" type="checkbox"/>					
Address 5	<input checked="" type="checkbox"/>	OFF	<input checked="" type="checkbox"/>					
Address 6	OFF	<input checked="" type="checkbox"/>	<input checked="" type="checkbox"/>					
Address 7	<input checked="" type="checkbox"/>	<input checked="" type="checkbox"/>	<input checked="" type="checkbox"/>					

Table 2-2 DIP Switch S2 (Serial Port) * = default

AX-8 Option	SW1 Mode	SW2 Data	SW3 Parity	SW4 N/A	SW5 Baud 0	SW6 Baud 1	SW7 Baud 2	SW8 Baud 3
ASCII mode	OFF							
Binary (transparent) mode	<input checked="" type="checkbox"/>							
7 bit/Even parity		OFF	<input checked="" type="checkbox"/>					
8 bit/No parity		<input checked="" type="checkbox"/>	OFF					
8 bit/Even parity		<input checked="" type="checkbox"/>	<input checked="" type="checkbox"/>					
110 baud					OFF	OFF	OFF	OFF
300 baud					<input checked="" type="checkbox"/>	OFF	OFF	OFF
600 baud					OFF	<input checked="" type="checkbox"/>	OFF	OFF
1200 baud					<input checked="" type="checkbox"/>	<input checked="" type="checkbox"/>	OFF	OFF
2400 baud					OFF	OFF	<input checked="" type="checkbox"/>	OFF
4800 baud					<input checked="" type="checkbox"/>	OFF	<input checked="" type="checkbox"/>	OFF
9600 baud					OFF	<input checked="" type="checkbox"/>	<input checked="" type="checkbox"/>	OFF
19200 baud					<input checked="" type="checkbox"/>	<input checked="" type="checkbox"/>	<input checked="" type="checkbox"/>	OFF

3 Installation

3.1 Mechanical Installation

The AX-8 should be mounted in a dirt-free environment away from heat sources and high electrical fields. Mounting may be either standard DIN rail or wall mount. Only front access is required for wiring.

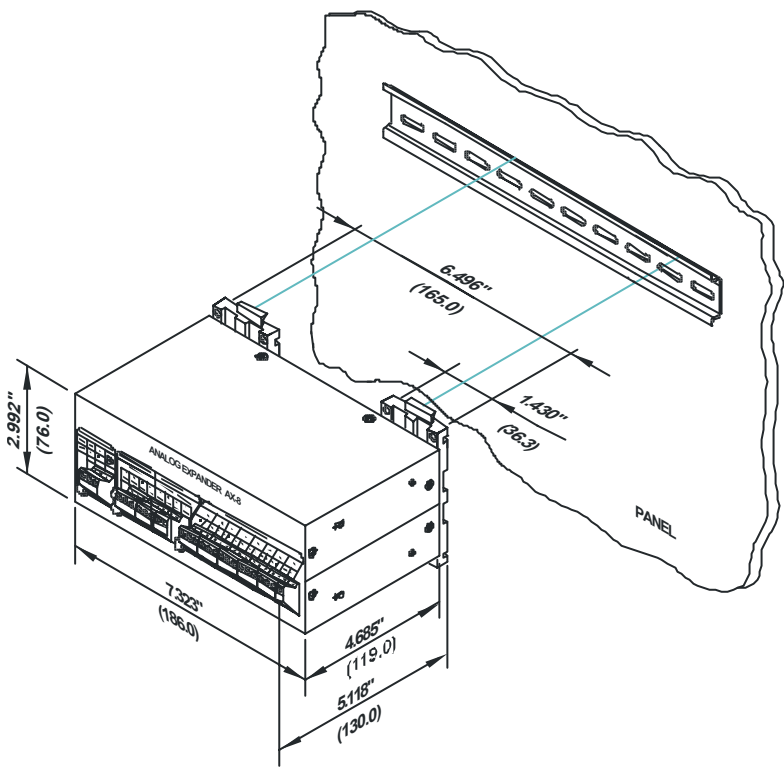

01-05001-1

Figure 3-1 Standard DIN Rail Mounting

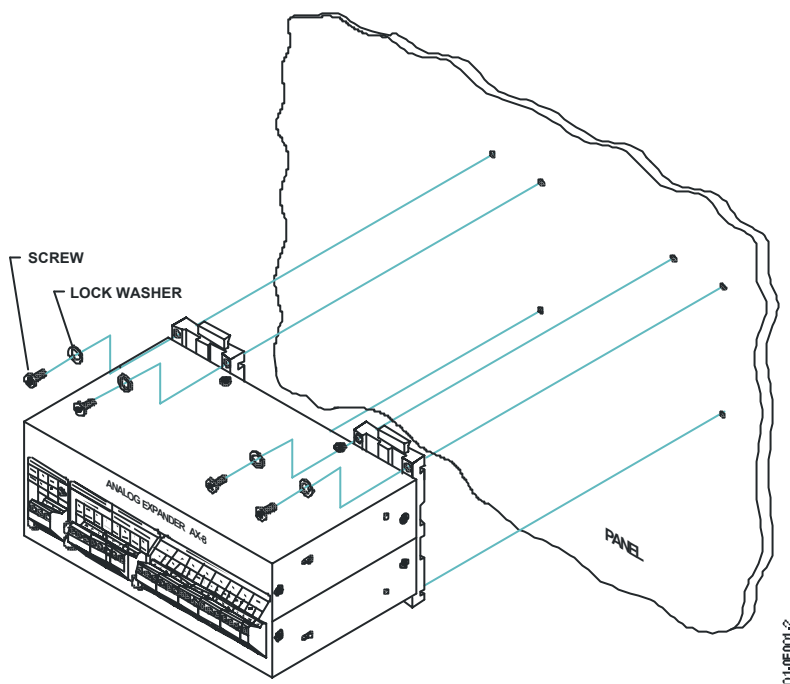

Figure 3-2 Wall Mounting

3.2 Electrical Installation

For AX-8 connections to the power supply, communications and analog outputs, see *Figures 3-3* (RS-422 network) or *3-4* (RS-485 network).

Power Supply

Use a dedicated breaker from a proper power source, from which the unit can be turned off. All AX-8 analog outputs are provided with an internal power supply; no external power supply for analog outputs is required.

Communications

The AX-8 is connected on one side to the Powermeter via the RS-422 input, and from the other side, to the multi-drop communication network via the RS422 or RS-485 output, using the ASCII, Modbus or DNP3.0 protocol.

Communications may be over a distance of up to 1000 meters and at a baud rate of up to 19,200 bps. A twisted pair cable of 0.33mm²/22AWG is recommended.

Analog Output Options

Current output options

0-20mA, 4-20mA

0-1mA, ± 1 mA

Voltage output options

0-10V DC and ± 10 V DC

Loads must be connected to analog outputs 1-8 according to their polarity.

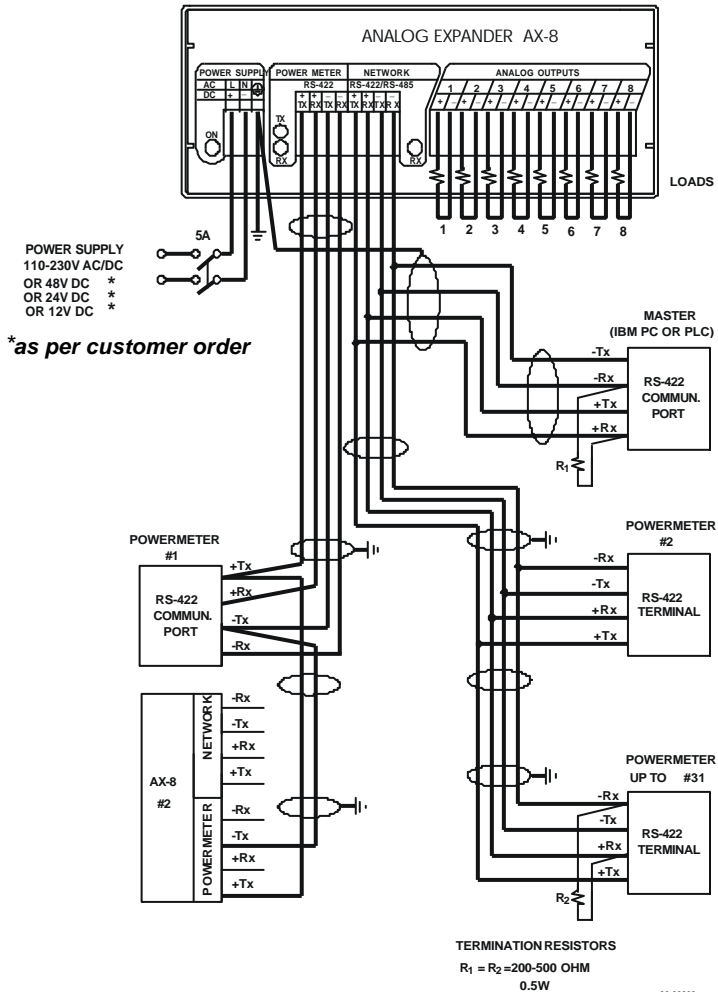

Figure 3-3 AX-8 Connections in RS-422 Network

☞ **Be sure that all incoming AC power and other power sources are turned OFF before performing any connections.**

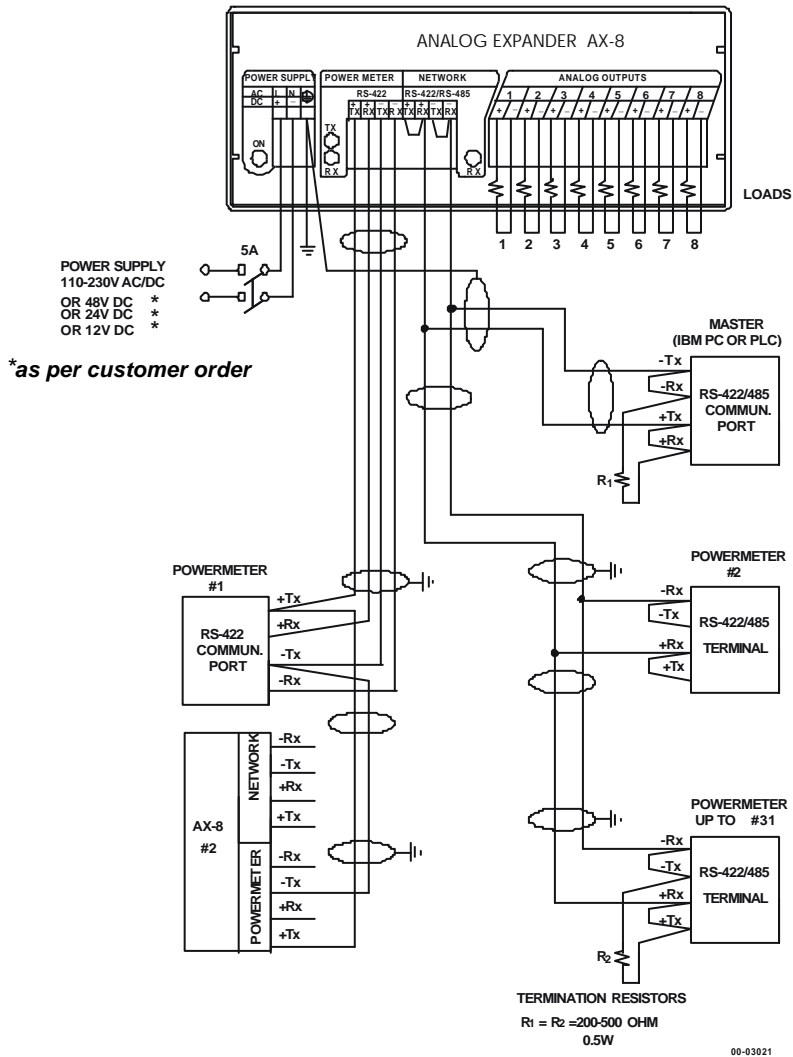

Figure 3-4 AX-8 Connections in RS-485 Network

☞ **Be sure that all incoming AC power and other power sources are turned OFF before performing any connections.**

4 Operation

Refer to the Installation and Operation Manual of the specific Powermeter for instructions on Analog Expander and communication parameters setup.

4.1 Power Up

Close the power feed breaker; the 'ON' LED will light up.

4.2 Communication

When you program your powermeter to output data to external analog outputs, the powermeter periodically updates the AX-8 analog outputs (each 300-500 ms) via the pair of wires on the RS-422 communications link used for transmitting data. At that time, the transmission (output) line of the AX-8 is disconnected from the external network, while the receive line is directly connected to the powermeter port so that the instrument is constantly 'listening' to the network.

When data is requested from the powermeter by a master computer (or controller), the powermeter instructs the AX-8 to switch the transmission line to the external network, and then sends the response. After the response message is sent out, the transmission line is disconnected from the network and the powermeter continues updating the AX-8 outputs.

The AX-8 can work with different ASCII and non-ASCII network protocols. If you use an ASCII communications protocol, set the switch #1 on the DIP switch block S2 to OFF in order to put the AX-8 into ASCII mode. The ASCII message frame should be ended with two characters CR/LF (ASCII 13 and 10). If you are using non-ASCII communications protocol such as Modbus or DNP 3.0, set the switch #1 on the DIP switch block S2 to ON to put the AX-8 into binary (transparent) mode. In this event, the AX-8 will not decode the message frame and the transmission line is disconnected in 3.5 character time after the response message is sent out.

Indicator LEDs

The AX-8 is provided with a single Rx LED (network indication) and a pair of Rx-Tx LEDs (Powermeter indication) which operate as shown in *Figure 4-1*:

Transmission Status	LED Indication
no transmission	no LEDs lit up
Powermeter to AX-8	single Rx LED ('1' in <i>Figure 4-1</i>) flashes
RS-422: master to Powermeter Powermeter to master	Powermeter Tx LED ('2') flashes Powermeter Rx LED ('3') flashes
RS-485: master to Powermeter Powermeter to master	Powermeter Rx and Tx LEDs flash

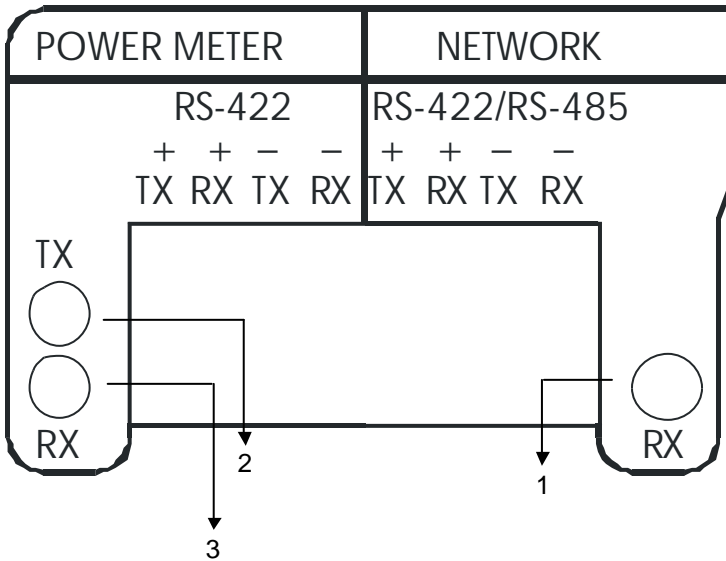

Figure 4-1 Detail of Communication LEDs on AX-8

5 Technical Specifications

Instrument serial communications	RS-422										
Network serial communications	RS-422 / RS-485										
Baud rate (bps)	110, 300, 600,1200, 2400, 4800, 9600, 19200										
Inter-channel separation	> 95dB										
Galvanic isolation: Power Supply Communication	2500V rms 1000V DC										
Accuracy	±0.5% of full scale for current output up to 2500 Ω ±2.0% of full scale for current output from 2500 Ω to 10000 Ω										
Temperature coefficient	±50ppm/°C										
Resolution	8 bits										
Current output	<table border="0"> <thead> <tr> <th><u>Span (factory set)</u></th> <th><u>External resistance</u></th> </tr> </thead> <tbody> <tr> <td>4-20mA</td> <td>up to 750 Ω</td> </tr> <tr> <td>± 1mA</td> <td>up to 10000 Ω</td> </tr> <tr> <td>0-20mA</td> <td>up to 750 Ω</td> </tr> <tr> <td>0-1mA</td> <td>up to 10000 Ω</td> </tr> </tbody> </table>	<u>Span (factory set)</u>	<u>External resistance</u>	4-20mA	up to 750 Ω	± 1mA	up to 10000 Ω	0-20mA	up to 750 Ω	0-1mA	up to 10000 Ω
<u>Span (factory set)</u>	<u>External resistance</u>										
4-20mA	up to 750 Ω										
± 1mA	up to 10000 Ω										
0-20mA	up to 750 Ω										
0-1mA	up to 10000 Ω										
Voltage output	<table border="0"> <tbody> <tr> <td>0-10V DC</td> <td>from 1000 Ω</td> </tr> <tr> <td>±10V DC</td> <td>from 1000 Ω</td> </tr> </tbody> </table>	0-10V DC	from 1000 Ω	±10V DC	from 1000 Ω						
0-10V DC	from 1000 Ω										
±10V DC	from 1000 Ω										
Power supply ratings (factory set) 120&230 V AC and 110&220 V DC option 12 V DC option 24 V DC option 48 V DC	90- 264V AC 50/60 Hz and 110 - 290V DC burden 10 W 10 - 16 VDC 18 - 36 VDC 36 - 72 VDC										
Ambient temperature	Operation: -20°C to +60°C Storage: -25°C to +80°C										
Humidity	95% max. non-condensing										
Enclosure	Aluminum, anodized										
Mounting	35 mm DIN rail or wall mount										
Weight	0.6 kg (1.32 lb.)										
Dimensions	186 x 75 x 109 mm (7.33 x 2.95 x 4.3 inch)										

Technical Specifications (continued)

Standards	UL File # E129258 CE-EMC: 89/336/EEC as amended by 92/31/EEC and 93/68/EEC CE-SAFETY: 72/23/EEC as amended by 93/68/EEC and 93/465/EEC Harmonized standards to which conformity is declared: EN55011:1991; EN50082-1:1992; EN61010-1:1993; A2/1995 ANSI C37.90.1 1989 Surge Withstand Capability (SWC) ANSI C62.41 - 1991 Standard Surge EN50081-2 Generic Emission Standard - Industrial Environment EN50082-2 Generic Immunity Standard - Industrial Environment EN55022: 1994 Class A EN61000-4-2 ENV50140: 1983 ENV50204: 1995 (900MHz) ENV50141: 1993 EN61000-4-4:1995 EN61000-4-8: 1993
-----------	--